

TRACKER

OFF ROAD™

SERVICE MANUAL



p/n: 2263-157
7/21

500S

Table of Contents

General Information/Foreword	2	Engine/Transmission	40
Specifications	2	Troubleshooting	41
Torque Specifications	3	Removing Engine/Transmission	43
Torque Conversions (ft-lb/N-m)	4	Servicing Engine	47
Gasoline — Oil — Lubricant	4	Installing Engine/Transmission	86
Preparation for Storage	5	Fuel/Lubrication/Cooling	91
Preparation after Storage	6	Throttle Body	91
Periodic Maintenance/Tune-Up	7	Gas Tank	92
Air Inlet Pre-Filter	7	Oil Pump	94
Air Filter/Housing Drain	7	Liquid Cooling System	95
Valve/Tappet Clearance.....	8	Troubleshooting	98
Testing Engine Compression.....	9	Electrical System	99
Spark Plug	10	Battery	99
Muffler/Spark Arrester.....	10	Ignition Switch.....	100
Engine/Transmission Oil — Filter	10	Ignition Coil	100
Front Differential — Rear Drive Lubricant	11	Ignition Timing.....	101
Driveshaft/Coupling	12	Accessory Connector.....	101
Headlight — Taillight/ Brake Light — Reverse Light.....	12	Switches	102
Shift Cable	13	Fan Motor	104
Hydraulic Brake System	14	Power Distribution Module (PDM)	104
Burnishing Brake Pads.....	16	EFI Sensors/Components.....	105
Checking/Replacing V-Belt.....	16	RPM Limiter	110
Steering/Body/Controls	19	Stator Coil.....	110
Steering Wheel	19	Regulator/Rectifier	110
Steering System	19	Starter Motor.....	111
Steering Knuckles.....	23	Starter Relay.....	111
Accelerator Pedal	25	Electronic Control Module (ECM)	112
Shift Lever	26	EFI Diagnostic System	112
Shift Cable	26	Troubleshooting	117
LCD Gauge.....	28	Drive System	118
Front Wheel Alignment	28	Front Drive Actuator	118
Front Fascia/Front Bumper	28	Front Differential	120
Hood/Front Storage Compartment	30	Drive Axles.....	132
Front Body Panel.....	30	Rear Gear Case.....	136
Floor	31	Hub	142
Dashboard	33	Hydraulic Brake Caliper	144
Belly Panel.....	35	Troubleshooting Drive System.....	148
Muffler.....	35	Troubleshooting Brake System.....	148
Cargo Box.....	36	Suspension	149
Tailgate	36	Shock Absorbers.....	149
Taillight Assembly	37	Front A-Arms.....	149
Seat	38	Rear A-Arms	152
Troubleshooting	39	Wheels and Tires	154
		Troubleshooting	155

General Information/ Foreword



This Service Manual contains service, maintenance, and troubleshooting information for the 2022 500S model. The complete manual is designed to aid service personnel in service-oriented applications.

This manual is divided into sections. Each section covers a specific vehicle component or system and, in addition to the standard service procedures, includes disassembling, inspecting, and assembling instructions. When using this manual as a guide, the technician should use discretion as to how much disassembly is needed to correct any given condition.

This service manual is designed primarily for use by a basic level technician. The procedures found in this manual are of varying difficulty, and certain service procedures in this manual require one or more special tools to be completed. The technician should use sound judgment when determining which procedures can be completed based on their skill level and access to appropriate special tools.

NOTE: Whenever a part is worn excessively, cracked, or damaged in any way, replacement is necessary.

When replacement of parts is necessary, use only genuine parts. They are precision-made to ensure high quality and correct fit. Refer to the appropriate Illustrated Parts Manual for the correct part number, quantity, and description.

All publications and decals display the words Warning, Caution, Note, and At This Point to emphasize important information. The symbol  **WARNING** identifies personal safety-related information. Be sure to follow the directive because it deals with the possibility of serious personal injury or even death. A **CAUTION** identifies unsafe practices which may result in vehicle-related damage. Follow the directive because it deals with the possibility of damaging part or parts of the vehicle. The symbol  **NOTE:** identifies supplementary information worthy of particular attention. The symbol  **AT THIS POINT** directs the technician to certain and specific procedures to promote efficiency and to improve clarity.

At the time of publication, all information, photographs, and illustrations were technically correct. Some photographs used in this manual are used for clarity purposes only and are not designed to depict actual conditions. Because we constantly refine and improve our products, no retroactive obligation is incurred.

All materials and specifications are subject to change without notice.

Specifications

NOTE: Specifications subject to change without notice.

CHASSIS	
Dry Weight (approx)	496.7 kg (1095 lb)
ROPS Tested Curb Weight	997.9 kg (2200 lb)
Length (overall)	270.3 cm (106.4 in.)
Height (overall)	194.8 cm (76.7 in.)
Width (overall)	143.3 cm (56.4 in.)
Tire Size	(front) 25 x 8-12 (rear) 25 x 10-12
Tire Inflation Pressure (w/cargo)	(front) 82.7 kPa (12 psi) (rear) 137.9 kPa (20 psi)
MISCELLANEOUS	
Spark Plug Type	NGK CR6E
Spark Plug Gap	0.7-0.8 mm (0.028-0.031 in.)
Gas Tank Capacity	32.2 L (8.5 U.S. gal.)
Coolant Capacity	2.5 L (2.65 U.S. qt)
Front Differential Capacity (change)	250 ml (8.45 fl oz)*
Rear Drive Capacity (change)	230 ml (7.78 fl oz)*
Engine Oil Capacity (approx)	2.8 L (3.0 U.S. qt) — Overhaul 2.4 L (2.5 U.S. qt) — Change
Gasoline (recommended)	87 Octane Regular Unleaded
Engine Oil (recommended)	ACX All Weather Synthetic
Front Differential/Rear Drive Lubricant (At level plug hole)	SAE Approved 80W-90 Hypoid
Drive Belt Width	28.5 mm (1.12 in.)
Brake Fluid	DOT 4
Taillight/Brake Light/Reverse light	12V/5W/21W
Headlight (high beam/low beam)	12V/60W/55W
ELECTRICAL SYSTEM	
Ignition Timing	12° BTDC @ 1425 RPM
Spark Plug Cap	4000-6000 ohms
Ignition Coil Resistance	(primary) Less than 1 ohm (secondary) N/A
Ignition Coil Primary Voltage	Battery Voltage
Stator Coil Resistance	(CKP Sensor) 104-156 ohms (AC generator) Less than 1 ohm
AC Generator Output (no load)	75 AC volts @ 5000 RPM
Crankshaft Position Sensor AC Voltage	2.0 volts or more
VALVES AND GUIDES	
Valve Face Diameter	(intake) 30.6 mm (exhaust) 27.0 mm
Valve/Tappet Clearance (cold engine)	(intake) 0.10 mm (exhaust) 0.17 mm
Valve Guide/Stem Clearance (max)	(intake) 0.04 mm (exhaust) 0.06 mm
Valve Guide Inside Diameter	5.000-5.012 mm
Valve Seat Angle	(intake/exhaust) 45°
Valve Spring Free Length (min)	42.8 mm
Valve Spring Tension @ 35.2 mm	18.6 kg (41.1 lb)

CYLINDER, PISTON, AND RINGS	
Piston Skirt/Cylinder Clearance	0.60-0.73 mm
Piston Diameter 15 mm from Skirt End	88.96-88.98 mm
Piston Ring Free End Gap (max)	(1st) 8.0 mm (2nd) 8.3 mm
Bore x Stroke	89.0 x 71.2 mm
Cylinder Trueness (max)	0.01 mm
Piston Ring End Gap — Installed (min)	0.30 mm
Piston Ring to Groove Clearance (max) (1st/2nd)	0.06 mm
Piston Ring Groove Width	(1st) 1.01-1.03 mm (2nd) 1.21-1.23 mm (oil) 2.01-2.03 mm
Piston Ring Thickness	(1st) 1.01-1.03 mm (2nd) 1.17-1.19 mm
Piston Pin Bore (max)	20.008 mm
Piston Pin (min)	19.994 mm
CRANKSHAFT	
Connecting Rod (small end) (max)	20.021 mm
Connecting Rod (big end side-to-side)	0.10-0.55 mm
Connecting Rod (big end width)	21.95-22.00 mm
Connecting Rod (small end deflection) (max)	3.0 mm
Crankshaft (web-to-web)	60.9 mm
Crankshaft Runout (max)	0.03 mm
CAMSHAFT AND CYLINDER HEAD	
Cam Lobe Height (min)(intake) (exhaust)	34.71 mm 34.48 mm
Camshaft Journal Holder (right & center) Inside Diameter (left)	22.01-22.04 mm 17.51-17.54 mm
Camshaft Journal Outside(right & center) Diameter (left)	17.466-17.480 mm 21.959- 21.980 mm
Camshaft Runout (max)	0.03 mm
Cylinder Head/Cover Distortion (max)	0.05 mm

Torque Specifications

■NOTE: Torque specifications have the following tolerances:

Torque (ft-lb)	Tolerance
0-15	±20%
16-39	±15%
40+	±10%

Part	Part Bolted to	Torque	
		ft-lb	N-m
EXHAUST COMPONENTS			
Exhaust Pipe	Cylinder Head	15	20.4
Spark Arrester	Muffler	50 in.-lb	5
O2 Sensor	Exhaust Pipe	18.5	25
BRAKE COMPONENTS			
Brake Disc (Front/Rear)**	Hub	25	34
Brake Hose	Caliper	25	34
Brake Hose	Master Cylinder	25	34
Master Cylinder	Frame	15.5	21
Caliper****	Knuckle	20	27.2
Brake Pedal	Frame	15.6	21.1
Rear Caliper Bracket	Gear Case	32	45
Banjo Bolt	Brakeline Junction	18	25
ELECTRICAL COMPONENTS			
Coil*	Bracket	8	11
STEERING COMPONENTS			
Steering Wheel**	Steering Shaft	25	34
Rack and Pinion Assembly	Frame	35	48
Tie Rod End**	Knuckle	30	41
Tie Rod	Tie Rod End	8	11
Intermediate Shaft	Steering Column	15	20.4
Intermediate Shaft	Rack	15	20.4
Tilt Assembly	Steering Support	23	31.3
Gas Spring	Steering Support	15	20.4
CHASSIS/ROPS ASSEMBLY			
Shift Axle Support	Frame	48 in.-lb	5
Front/Rear ROPS Tube	Arm Rest/Steering Support	47	64
Top ROPS Support	Front/Rear ROPS Tubes	47	64
Rear ROPS Tube	Lower ROPS Support	47	64
Shift Lever/Lever Assembly	Frame	15	20.4
Shift Cable Mounting/Adjuster	Shift Cable	20	27
Seat Belt Loop	ROPS	42	57
Side Panel/Spacer	Cargo Box Frame	25	34
Tilt Pivot Bushing	Cargo Box Frame	15	20.4
Latch Striker	Cargo Box Liner	60 in.-lb	7

Part	Part Bolted to	Torque	
		ft-lb	N-m
SUSPENSION COMPONENTS (Front)			
A-Arm	Frame	35	48
Knuckle	Ball Joint	35	48
Shock Absorber	Frame/Upper A-Arm	32.5	44
SUSPENSION COMPONENTS (Rear)			
A-Arm	Frame	35	48
Shock Absorber	Lower A-Arm/Frame	32	43.5
Knuckle	A-Arm	35	48
DRIVETRAIN COMPONENTS			
Gear Case	Frame	39	53
Front Differential	Frame	39	53
Differential Gear Stay	Frame	23	31.3
Pinion Housing	Differential Housing	16.5	22
Driveshaft Flange (Front/Rear)	Engine Flange	20	27.2
Front/Rear Drive Flange	Secondary Output Shaft	59	80
Differential Housing Cover***	Differential Housing	16.5	22
Drive Bevel Gear Nut***	Shaft	72	98
Driven Bevel Gear	Shaft	101	137
Hub Nut	Front/Rear Shaft/Axle (min)	200	271
Oil Drain Plug/Check Plug	Rear Gear Case	15	20.4
Filler Cap	Rear Gear Case	11	15
Drain Plug	Front Differential	23 in.-lb	2.6
Check Plug	Front Differential	7.2	9.8
Oil Fill Plug	Front Differential	25	34
Engine Oil Drain Plug	Engine	18	24.5
Wheel (Steel)	Hub	45	61
Wheel (Aluminum w/black nuts)	Hub	60	81
Wheel (Aluminum w/chrome nuts)	Hub	80	108
ENGINE/TRANSMISSION			
Engine Cradle	Frame	25	34
Engine Cradle	Engine	43	58
Cam Sprocket**	Camshaft	10	14
Valve Cover	Cylinder Head	8.5	11.5
Tappet Cover	Valve Cover	8.5	11.5
Cylinder Head (Cap Screw)	Crankcase	28	38
Cylinder/Cylinder Head (Nut)	Cylinder	8	11
Clutch Shoe**	Crankshaft	147	199
Driven Pulley**	Driveshaft	85	115
Ground Wire	Engine	8	11
Magneto Cover	Crankcase	10	14
Speed Sensor Housing	Crankcase	8	11
CVT Cover	Clutch Cover/Housing	8	11
Movable Drive Face	Centrifugal Clutch Housing	85	115
Starter Clutch**	Flywheel	16	22
Rotor	Crankshaft	107	145
Stator Coil**	Magneto Cover (New)	13	18
Stator Coil	Magneto Cover (Existing)	11.5	15
Oil Strainer	Crankcase	54 in.-lb	6
Oil Pump**	Crankcase	8.5	11.5
Water Pump/Housing	Magneto Cover	8	11
Crankcase Half (6 mm)	Crankcase Half	10	14
Crankcase Half (8 mm)	Crankcase Half	21	28
Starter Motor	Crankcase	10	14
Shift Cam Plate	Shift Cam Shaft	8	11
Oil Pump Drive Gear**	Crankshaft	63	85
Cam Chain Tensioner Guide	Cylinder Head	11	15
Cam Chain Tensioner	Cylinder	10	14
Water Pump Drive Gear	Crankshaft	28	38
Water Pump Cover	Water Pump Housing	8	11

* w/Blue Loctite #243 ** w/Red Loctite #271

*** w/Green Loctite #270 **** w/“Patch-Lock”

Torque Conversions (ft-lb/N-m)

ft-lb	N-m	ft-lb	N-m	ft-lb	N-m	ft-lb	N-m
1	1.4	26	35.4	51	69.4	76	103.4
2	2.7	27	36.7	52	70.7	77	104.7
3	4.1	28	38.1	53	72.1	78	106.1
4	5.4	29	39.4	54	73.4	79	107.4
5	6.8	30	40.8	55	74.8	80	108.8
6	8.2	31	42.2	56	76.2	81	110.2
7	9.5	32	43.5	57	77.5	82	111.5
8	10.9	33	44.9	58	78.9	83	112.9
9	12.2	34	46.2	59	80.2	84	114.2
10	13.6	35	47.6	60	81.6	85	115.6
11	15	36	49	61	83	86	117
12	16.3	37	50.3	62	84.3	87	118.3
13	17.7	38	51.7	63	85.7	88	119.7
14	19	39	53	64	87	89	121
15	20.4	40	54.4	65	88.4	90	122.4
16	21.8	41	55.8	66	89.8	91	123.8
17	23.1	42	57.1	67	91.1	92	125.1
18	24.5	43	58.5	68	92.5	93	126.5
19	25.8	44	59.8	69	93.8	94	127.8
20	27.2	45	61.2	70	95.2	95	129.2
21	28.6	46	62.6	71	96.6	96	130.6
22	29.9	47	63.9	72	97.9	97	131.9
23	31.3	48	65.3	73	99.3	98	133.3
24	32.6	49	66.6	74	100.6	99	134.6
25	34	50	68	75	102	100	136

Gasoline — Oil — Lubricant

FILLING GAS TANK

WARNING

Always fill the gas tank in a well-ventilated area. Never add fuel to the gas tank near any open flames or with the engine running. DO NOT SMOKE while filling the gas tank.

Since gasoline expands as its temperature rises, the gas tank must be filled to its specified capacity only. Expansion room must be maintained in the tank particularly if the tank is filled with cold gasoline and then moved to a warm area.

WARNING

Do not overflow gasoline when filling the gas tank. A fire hazard could materialize. Always allow the engine to cool before filling the gas tank.

Tighten the gas tank cap securely after filling the tank.

WARNING

Do not over-fill the gas tank.

RECOMMENDED GASOLINE

The recommended gasoline to use is 87 minimum octane regular unleaded. In many areas, oxygenates are added to the gasoline. Oxygenated gasolines containing up to 10% ethanol or 5% methanol are acceptable gasolines.

When using ethanol-blended gasoline, it is not necessary to add a gasoline antifreeze since ethanol will prevent the accumulation of moisture in the fuel system.

CAUTION

Do not use white gas. Only approved gasoline additives should be used.

RECOMMENDED ENGINE/TRANSMISSION OIL

CAUTION

Any oil used in place of the recommended oil could cause serious engine damage. Do not use oils which contain graphite or molybdenum additives. These oils can adversely affect clutch operation. Also, not recommended are racing, vegetable, non-detergent, and castor-based oils.

The recommended oil to use is ACX All Weather synthetic engine oil, which has been specifically formulated for use in this engine. Although ACX All Weather synthetic engine oil is the only oil recommended for use in this engine, use of any API-certified SM 0W-40 oil is acceptable.

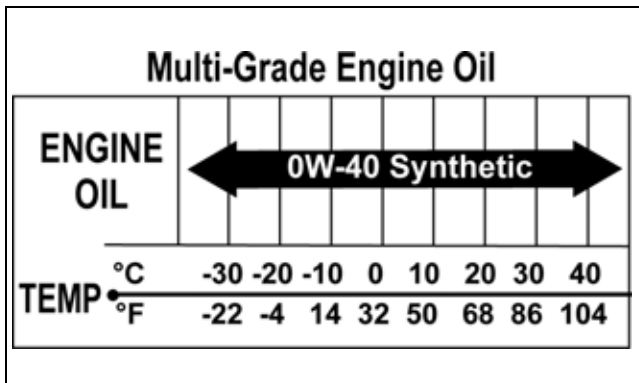

OILCHARTJ

RECOMMENDED FRONT DIFFERENTIAL/REAR DRIVE LUBRICANT

The recommended lubricant is SAE-approved 80W-90 hypoid. This lubricant meets all of the lubrication requirements of the front differential and rear drive.

CAUTION

Any lubricant used in place of the recommended lubricant could cause serious front differential/rear drive damage.

Preparation for Storage

The manufacturer recommends the following procedure to prepare the vehicle for storage. An authorized dealer should perform this service; however, the owner/operator may perform this service if desired.

CAUTION

Prior to storing this vehicle, it must be properly serviced to prevent rusting and component deterioration.

1. Clean the vehicle thoroughly by washing dirt, oil, grass, and other foreign matter from the entire vehicle. Allow the vehicle to dry thoroughly. DO NOT get water into any part of the engine or air intake.
2. Either drain the gas tank or add a fuel stabilizer to the gas in the gas tank.
3. Clean the interior of the air filter housing.
4. Plug the hole in the exhaust system with steel wool.
5. Apply light oil to the upper steering shaft via the access hole. Remove the rubber plug located on the left side of the steering column cover and plungers of the shock absorbers.



PK094A

6. Tighten all nuts, bolts, cap screws, and screws. Make sure rivets holding components together are tight. Replace all loose rivets. Care must be taken that all calibrated nuts, cap screws, and bolts are tightened to specifications.
 7. Fill the cooling system to the bottom of the stand pipe in the radiator neck with properly mixed coolant. Check the coolant level in the reservoir tank; it should be in between the MIN and MAX markings.
 8. Disconnect the battery cables (negative cable first); then remove the battery, clean the battery posts and cables, and store in a clean, dry area.
- NOTE: For storage, use a battery maintainer or make sure the battery is fully charged (see Battery section in this manual).
9. Store the vehicle indoors in a level position.

CAUTION

Avoid storing outside in direct sunlight and avoid using a plastic cover as moisture will collect on the vehicle causing rusting.

Preparation after Storage

Taking this vehicle out of storage and correctly preparing it will ensure many hours of trouble-free riding. The manufacturer recommends the following procedure:

1. Clean the vehicle thoroughly.
2. Remove the steel wool from the exhaust system.
3. Check all control wires and cables for signs of wear or fraying. Replace if necessary.
4. Change the engine/transmission oil and filter.
5. Check the coolant level and add properly mixed coolant as necessary.

6. Charge the battery; then install. Connect the battery cables making sure to connect the positive cable first.

CAUTION

Before installing the battery, make sure the ignition switch is in the OFF position.

7. Check the entire brake systems (fluid level, pads, etc.), all controls, headlights, taillight, brake light, and headlight aim; adjust or replace if necessary.
8. Check the tire pressure. Inflate to recommended pressure as necessary.
9. Tighten all nuts, bolts, cap screws, and screws making sure all calibrated nuts, cap screws, and bolts are tightened to specifications.
10. Make sure the steering moves freely and does not bind.
11. Check the spark plug. Clean or replace as necessary.
12. Check the air filter and the air filter housing. Clean or replace as necessary.

Periodic Maintenance/ Tune-Up

Tighten all nuts, bolts, and cap screws. Care must be taken that all calibrated nuts, bolts, and cap screws are tightened to specifications.

It is advisable to lubricate certain components periodically to ensure free movement. Apply light oil to the components using the following list as reference:

- A. Accelerator Pedal Pivot/Cable Ends
- B. Brake Pedal Pivot
- C. Shift Cable

SPECIAL TOOLS

A number of special tools must be available to the technician when performing service procedures in this section. Refer to the current Special Tools Catalog for the appropriate tool description.

■NOTE: When indicated for use, each special tool will be identified by its specific name, as shown in the chart below, and capitalized.

Description	p/n
Compression Tester Kit	Common Tool
Oil Filter Wrench	Common Tool
Timing Light	Common Tool
Valve Clearance Adjuster	0444-255

■NOTE: Special tools are available from the Service Department.

Air Inlet Pre-Filter

This vehicle is equipped with a pre-filter to filter dirt from the inlet air prior to reaching the main air filter.

■NOTE: The pre-filter is located above the front right wheel well under the front body panel.

1. To remove the pre-filter, remove the two machine screws; then remove the filter frame and filter from behind the inlet tube.



PK095

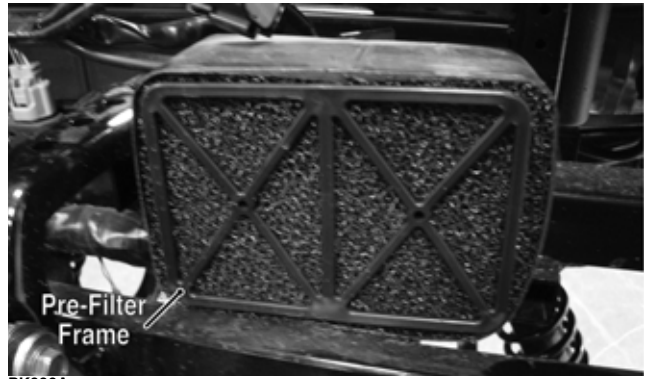

PK096A

2. Wash the pre-filter thoroughly in warm, soapy water; then rinse and dry.
3. Install the pre-filter and frame; then secure with the two machine screws. Tighten securely.

Air Filter/Housing Drain

The air filter inside the air filter housing must be kept clean to provide good engine power and gas mileage. If the vehicle is used under normal conditions, service the filter at the intervals specified. If operated in dusty, wet, or muddy conditions, inspect and service the filter more frequently. Use the following procedure to remove the filter and inspect and/or clean it.

CAUTION

Failure to inspect the air filter frequently if the vehicle is used in dusty, wet, or muddy conditions can damage the engine.

■NOTE: To access the air filter, the seat must be removed.

1. Remove dirt and debris from around the filter housing.
2. Unsnap the seven spring-clips and remove the air filter cover; then loosen the clamp securing the air filter.

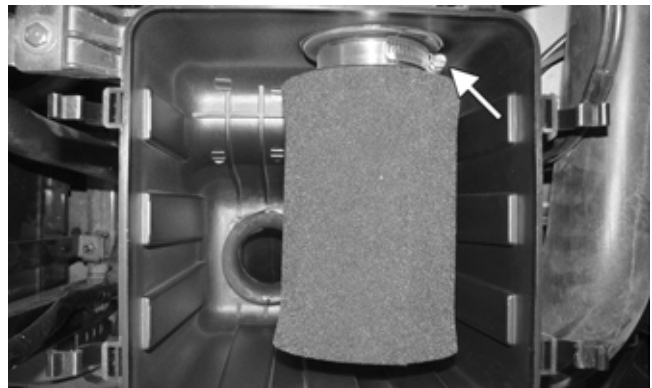

PK008A

3. Remove the Phillips screw to separate the air filter holders from the air filter.



PK321

- Slide out the air filter screen, then separate the inner and outer air filter elements to thoroughly clean.

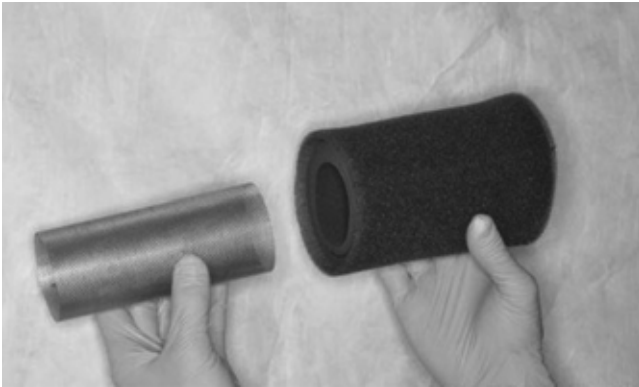

PK322

- Place the element in a pan larger than the element and spray all sides generously with cleaning solvent, let sit approximately 3 minutes.
- In a pan larger than the element, with a mild detergent (dish soap) and water, wash all the dirt and oil off by squeezing the element, not twisting it. (Ringing out or twisting the filter can cause damage.)

■**NOTE: Cleaning Solvent and Spray-On Foam Air Filter Oil are available from the manufacturer.**

- Rinse off any remaining soap.
- Remove any excess water from the element by matting with a towel.
- Allow the element to dry completely.
- Place the outer element over the inner air filter element.
- Spray oil generously onto air filter and work the oil into the element.
- Squeeze the element to remove excess oil.

CAUTION

A torn air filter can cause damage to the engine. Dirt and dust may get inside the engine if the element is torn. Carefully examine the element for tears before and after cleaning it. Replace the element with a new one if it is torn.

- Clean any dirt or debris from inside the filter housing.

- Inspect the drain cap beneath the main housing for debris and for proper sealing. From under the vehicle check the drain located on the bottom of the intake tube.

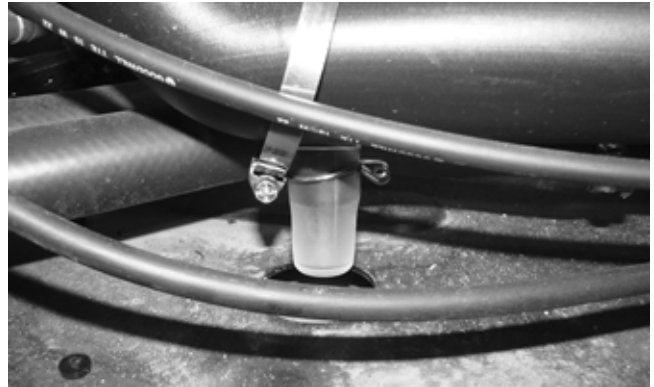

PK097



PK009

- Insert the air filter screen into the inner element then secure the air filter holders with the Phillips screw.
- Install the air filter and secure with the clamp.
- Install the air filter cover and secure with the spring-clips. Install the seat and make sure it is securely latched.

Valve/Tappet Clearance

■**NOTE: The engine must be cold for this procedure.**

■**NOTE: The seat and spark plug must be removed for this procedure. To aid in adjustment, it is recommended the cargo box also be removed (see Cargo Box section).**

- Remove the spark plug, timing inspection plug, and magneto cover plug; then remove the tappet covers (for more detailed information, see Engine/Transmission — Servicing Top-Side Components).



FI605A



FI603

2. Rotate the crankshaft to the TDC position on the compression stroke by aligning the rotor mark to the crankcase marking.

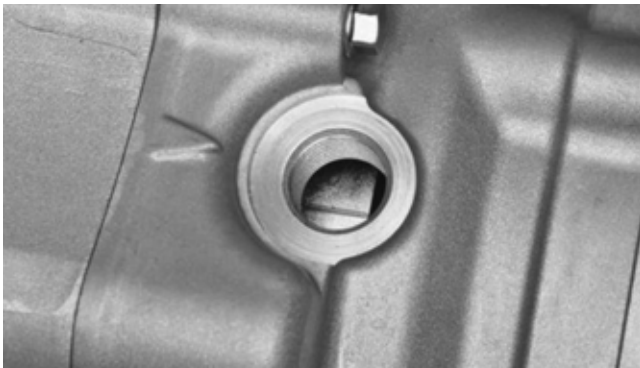

FI709

■NOTE: At this point, the rocker arms and adjuster screws must not have pressure on them.

CHECKING

Using a feeler gauge, check each valve/tappet clearance. If clearance is not within specifications, loosen the jam nut and rotate the tappet adjuster screw until the clearance is within specifications. Tighten each jam nut to 7 ft-lb (9.5 N-m) after completing the adjustment.

CAUTION

The feeler gauge must be positioned at the same angle as the valve and valve adjuster for an accurate measurement of clearance. Failure to measure the valve clearance accurately could cause valve component damage.

VALVE/TAPPET CLEARANCE	
Intake	0.1016 mm (0.004 in.)
Exhaust	0.1778 mm (0.007 in.)

ADJUSTING

- A. Place the Valve Clearance Adjuster onto the jam nut securing the tappet adjuster screw; then rotate the valve adjuster dial clockwise until the end is seated in the tappet adjuster screw.
- B. While holding the valve adjuster dial in place, use the valve adjuster handle and loosen the jam nut; then rotate the tappet adjuster screw clockwise until friction is felt.
- C. Align the valve adjuster handle with one of the marks on the valve adjuster dial.
- D. While holding the valve adjuster handle in place, rotate the valve adjuster dial counterclockwise until proper valve/tappet clearance is attained.

■NOTE: Refer to the specifications in CHECKING for the proper valve/tappet clearance.

■NOTE: Rotating the valve adjuster dial counterclockwise will open the valve/tappet clearance by 0.05 mm (0.002 in.) per mark.

- E. While holding the adjuster dial at the proper clearance setting, tighten the jam nut securely with the valve adjuster handle.
3. Install the spark plug; then install the timing inspection plug and magneto cover plug.
 4. Place the two tappet covers with O-rings into position. Tighten the cap screws to 8 ft-lb (10.9 N-m).

Testing Engine Compression

■NOTE: The engine should be warm (operating temperature) and the battery fully charged for an accurate compression test. The throttle must be in the wide-open throttle (WOT) position. In the event the engine cannot run up to operating temperature, cold values are included.

■NOTE: The seat must be removed for this procedure.

1. Remove the high tension lead from the spark plug.
2. Using compressed air, blow any debris from around the spark plug.

WARNING

Always wear safety glasses when using compressed air.

3. Remove the spark plug; then attach the high tension lead to the plug and ground the plug on the cylinder head well away from the spark plug hole.
4. Attach the Compression Tester Kit.

5. While holding the throttle in the full-open position, crank the engine over with the electric starter until the gauge stops climbing (five to 10 compression strokes).

PSI Hot (WOT)	PSI Cold (WOT)
125-145	100-140

6. If compression is abnormally low, inspect the following items:
- A. Starter cranks engine over.
 - B. Gauge is functioning properly.
 - C. Throttle in the full-open position.
 - D. Valve/tappet clearance correct.
 - E. Engine warmed up.
 - F. Intake obstructed.

■**NOTE:** To service top-side components, see Engine/Transmission.

7. Pour approximately 30 ml (1 fl oz) of oil into the spark plug hole, reattach the gauge, and retest compression.
8. If compression is now evident, service the top end (see the appropriate Engine/Transmission — Top-Side Components).

Spark Plug

A light brown insulator indicates that the plug and fuel/air ratio are correct. A white or dark insulator indicates that the engine may need to be serviced. To maintain a hot, strong spark, keep the plug free of carbon.

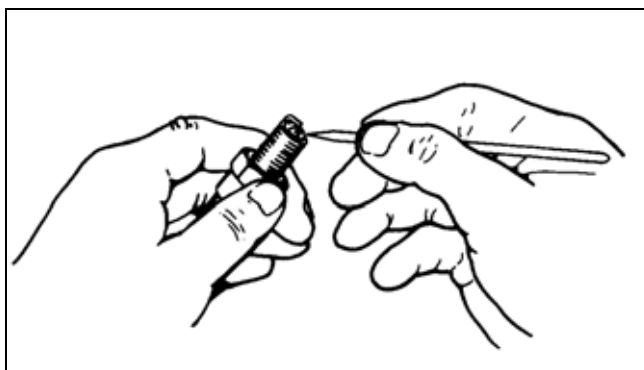

ATV-0051

CAUTION

Before removing the spark plug, be sure to clean the area around the spark plug. Dirt could enter engine when removing or installing the spark plug.

Adjust the gap to 0.7-0.8 mm (0.028-0.031 in.).

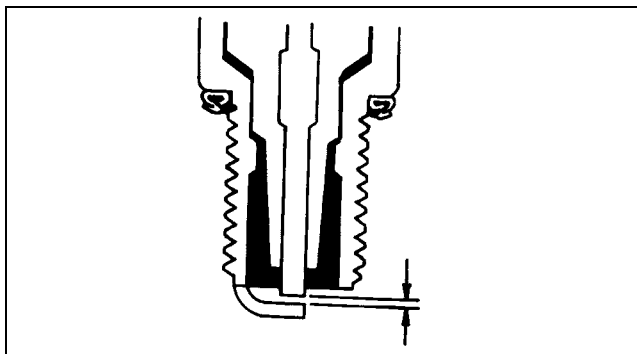

ATV0052

A new spark plug should be tightened 1/2 turn once the washer contacts the cylinder head. A used spark plug should be tightened 1/8-1/4 turn once the washer contacts the cylinder head.

Muffler/Spark Arrester

The muffler has a spark arrester which must be periodically cleaned. At the intervals shown in the Maintenance Schedule, clean the spark arrester using the following procedure:

⚠ WARNING

Wait until the muffler cools to avoid burns.

1. Remove the cap screws securing the spark arrester assembly to the muffler.

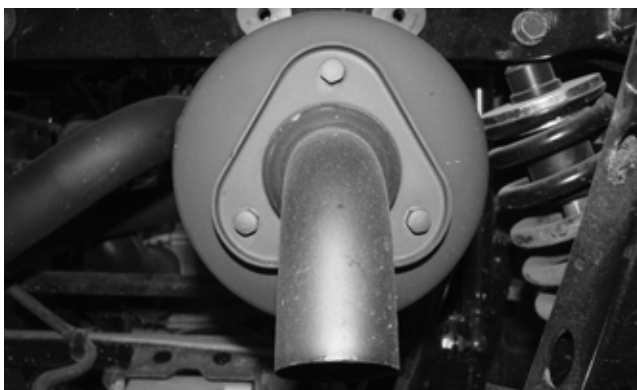

PK010

2. Using a suitable brush, clean the carbon deposits from the screen taking care not to damage the screen.

■**NOTE:** If the screen or gasket is damaged in any way, it must be replaced.

3. Install the spark arrester assembly and secure with the cap screws. Tighten to 50 in.-lb (5.6 N-m).

Engine/Transmission Oil — Filter

OIL — FILTER

Change the engine oil and oil filter at the scheduled intervals. The engine should always be warm when the oil is changed so the oil will drain easily and completely.

1. Park the vehicle on level ground.
2. Remove the drain plug from the bottom of the engine and drain the oil into a drain pan; then remove the seat. Account for and discard the drain plug gasket.

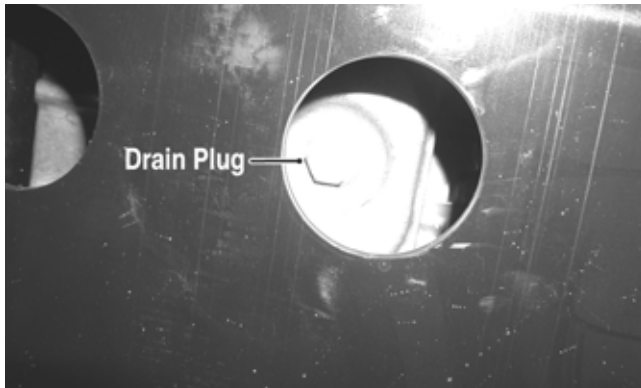

PR078A

3. Using the Oil Filter Wrench and a ratchet handle (or a socket or box-end wrench), remove the oil filter; then verify the oil filter seal has also been removed.

NOTE: Clean up any excess oil after removing the filter.

4. Apply fresh oil to the new filter O-ring and check to make sure it is positioned correctly; then install the new oil filter. Tighten securely.
5. Install the engine drain plug with a new gasket and tighten to 18 ft-lb (24.5 N-m). Pour the specified amount of the recommended oil in the filler hole (located on the right side of the engine).

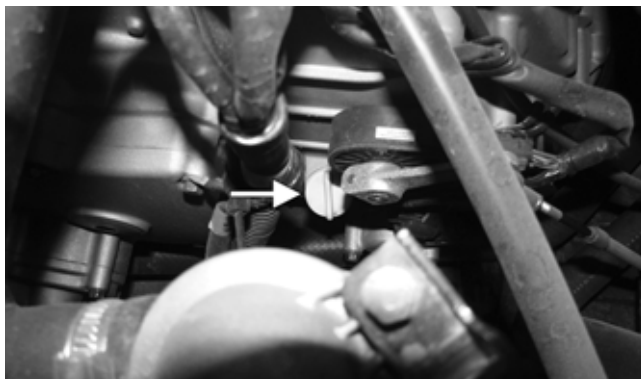

PK024A

CAUTION

Any oil used in place of the recommended oil could cause serious engine damage. Do not use oils which contain graphite or molybdenum additives. These oils can adversely affect clutch operation. Also, not recommended are racing, vegetable, non-detergent, and castor-based oils.

6. Start the engine (while the vehicle is outside on level ground) and allow it to idle for a few minutes.
7. Turn the engine off and wait approximately 1 minute; then unscrew the oil level stick and wipe it with a clean cloth.
8. Install the oil level stick and thread into the engine case.

9. Remove the oil level stick; the oil level must be within the operating range but not exceeding the upper mark.



GZ461A

CAUTION

Do not over-fill the engine with oil. Always make sure that the oil level is not above the upper mark.

10. Inspect the area around the drain plug and oil filter for leaks.

Front Differential – Rear Drive Lubricant

To check lubricant, use the following procedure:

1. Remove each level plug; the lubricant should be level with the bottom threads.

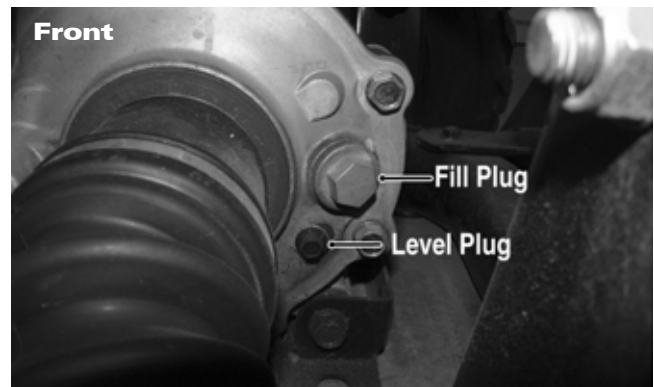

PK027A

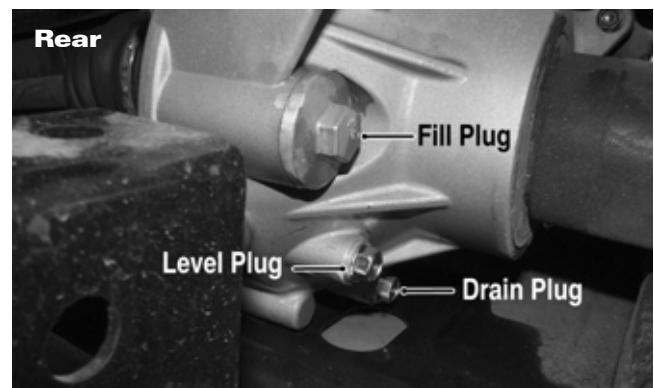

PK028A

2. If low, remove the fill plug and add the appropriate lubricant until it appears at the bottom of the level plug threads.

To change the lubricant, use the following procedure:

1. Place the vehicle on level ground.
2. Remove each fill plug; then inspect the seal (replace if necessary).
3. Drain the lubricant into a drain pan by removing in turn the drain plug from each; then inspect the seal (replace if necessary).

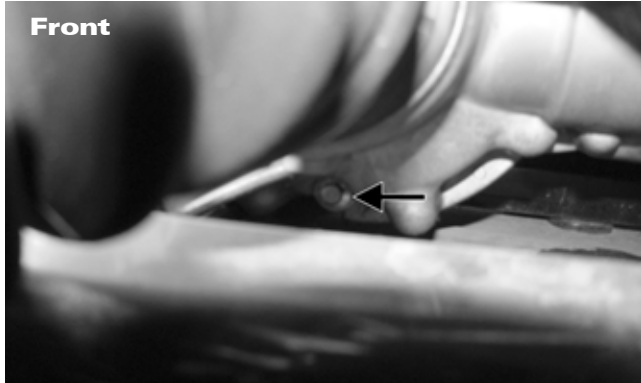

PK029A

4. After all the lubricant has been drained, install the drain plugs and tighten the front to 23 in.-lb (2.6 N-m) and rear to 15 ft-lb (20.4 N-m).
5. Pour the appropriate amount of recommended lubricant into the fill hole.
6. Install the fill plugs and tighten the front to 25 ft-lb (34 N-m) and the rear to 11 ft-lb (15 N-m).

■NOTE: If the lubricant is contaminated with water, inspect the drain plug, fill plug, and/or bladder.

Driveshaft/Coupling

The following drive system components should be inspected periodically to ensure proper operation:

1. Spline lateral movement (slop).
2. Coupling cracked, damaged, or worn.

Headlight — Taillight/ Brake Light — Reverse Light

■NOTE: The bulb portion is fragile. HANDLE WITH CARE. When replacing the bulb, do not touch the glass portion. If the glass is touched, it must be cleaned with a dry cloth before installing. Skin oil residue on the bulb will shorten the life of the bulb.

⚠ WARNING

Do not attempt to remove the bulb when it is hot. Severe burns may result.

HEADLIGHT

To replace the headlight bulb, use the following procedure:

1. Rotate the back of the headlight bulb counterclockwise; then disconnect the wiring harness and discard the bulb.

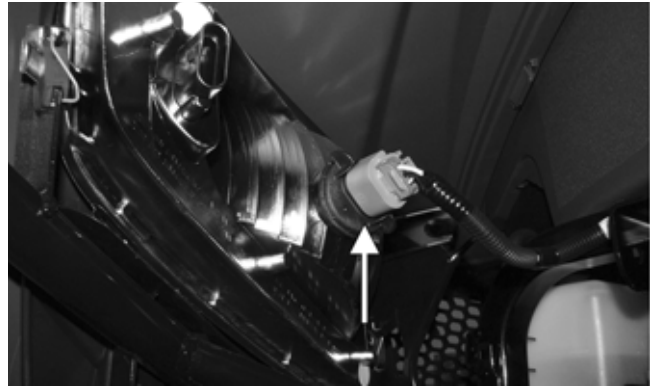

PK062A

2. Connect the new headlight bulb to the wiring harness and insert into headlight assembly. Turn clockwise to secure the bulb.
3. Adjust the headlight (see CHECKING/ADJUSTING HEADLIGHT AIM in this sub-section).

CAUTION

When replacing the headlight bulb, be careful not to touch the glass portion of the bulb. Grasp the new bulb with a clean cloth.

TAILLIGHT/BRAKE LIGHT — REVERSE LIGHT

To replace the taillight/brake light or reverse light bulb, use the following procedure:

1. Disconnect the taillight/brake light connector.
2. Remove the two nuts and cap screws securing the steel tie-down to the cargo box.

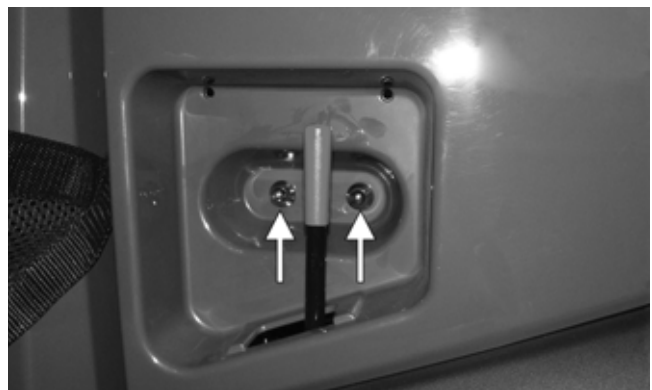

PK063B

3. Remove the six plastic screws securing the rear fender to the cargo box. Remove the rear fender.

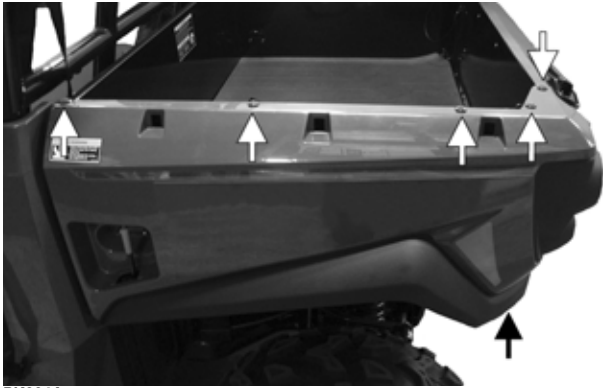

PK064A

- Remove the taillight/brake light socket by rotating the socket counterclockwise. Rotate the bulb counterclockwise to remove from socket.



PK328

- To install the taillight/brake light, insert the bulb into the socket and turn clockwise. Insert the socket into the taillight assembly and turn clockwise.
- Place the rear fender onto the cargo box and secure with the six plastic screws. Secure the tie-down with the two nuts and cap screws.
- Connect the taillight/brake light connector.

CHECKING/ADJUSTING HEADLIGHT AIM

The headlights can be adjusted vertically. The geometric center of the HIGH beam light zone is to be used for aiming.

- Position the vehicle on a level floor so the headlights are approximately 6.1 m (20 ft) from an aiming surface (wall or similar aiming surface).

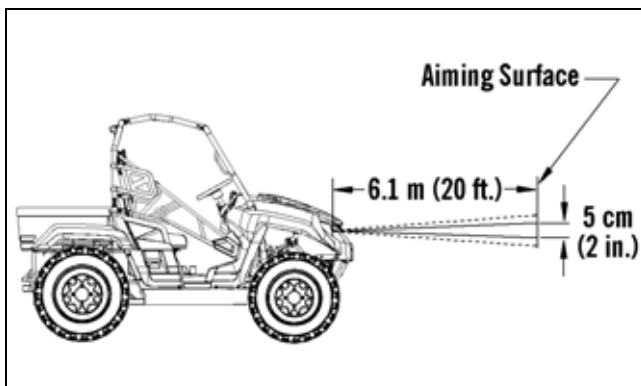

0748-733

■NOTE: There should be an average operating load on the vehicle when adjusting the headlight aim.

- Measure the distance from the floor to the midpoint of each headlight.
- Using the measurements obtained in step 2, make horizontal marks on the aiming surface.
- Make vertical marks which intersect the horizontal marks on the aiming surface directly in front of the headlights.
- Switch on the lights. Make sure the HIGH beam is on. DO NOT USE LOW BEAM.
- Observe each headlight beam aim. Proper aim is when the most intense beam is centered on the vertical mark 5 cm (2 in.) below the horizontal mark on the aiming surface.
- Loosen the headlight adjustment screw; then adjust the headlight up or down as required. Tighten the headlight adjustment screw.



PK081A

Shift Cable

CHECKING SHIFT CABLE

Turn the ignition switch on; then shift the transmission into park. The letter P should illuminate on the LCD gauge and the park icon (P) should illuminate. The vehicle should not be able to move.



PR098

Move the shift lever all the way forward. The letter L should illuminate on the LCD gauge.



PK099

If either park or low range cannot be reached, the shift cable must be adjusted.

ADJUSTING SHIFT CABLE

1. Place the transmission in park; then remove the seat.
2. Make sure the shift lever is in park; then remove the E-clip (A) securing the cable end to the shift arm stud. Account for the washer (B) and bushing (C).

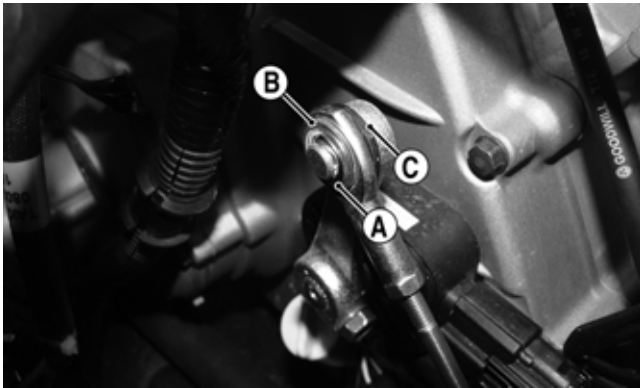

PK100A

3. Loosen nuts (A) and (B) found under the front body panel and adjust the cable housing to align the shift cable end to the shift arm stud.

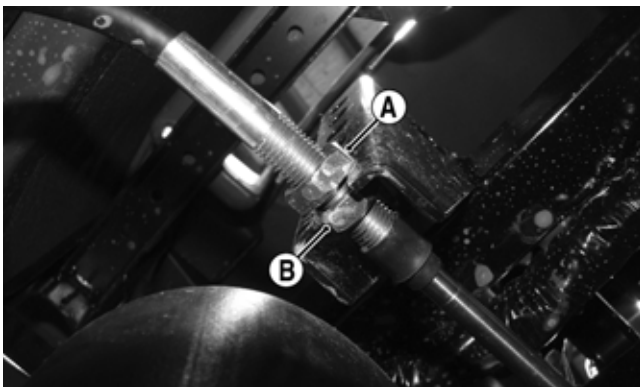

PK101A

4. If proper cable adjustment cannot be achieved after performing step 3, utilize the second cable adjustment found under the seat.



PK102

5. Place the bushing and cable end onto the shift arm stud; then install the washer and a new E-clip. Tighten the nuts (A) and (B) to 8 ft-lb (10.9 N-m).
6. Check each gear shift position for proper gear selection and make sure the proper icon illuminates on the LCD.

Hydraulic Brake System

■NOTE: This ROV is equipped with hydraulic brakes at the front wheels along with a shaft-mounted rear hydraulic brake.

CHECKING/BLEEDING

The hydraulic brake system has been filled and bled at the factory.

1. With the master cylinder in a level position, check the fluid level in the reservoir. If the level in the reservoir is not above the MIN, add DOT 4 brake fluid.



PK030A

2. Depress the brake pedal several times to check for a firm brake. If the brake is not firm, the system must be bled. To bleed the brake system, use the following procedure:
 - A. Remove the cover and fill the reservoir with DOT 4 brake fluid; then install and secure the cover.
 - B. Slowly depress the brake pedal several times.

- C. Install one end of a clear hose onto the REAR bleeder screw and direct the other end into a container; then while holding slight pressure on the brake pedal, open the bleeder screw and watch for air bubbles. Close the bleeder screw before releasing the brake pedal. Repeat this procedure until no air bubbles are present.

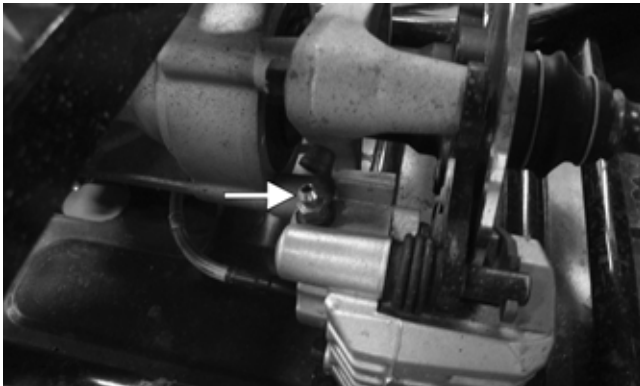

PK103A

■NOTE: During the bleeding procedure, watch the reservoir very closely to make sure there is always a sufficient amount of brake fluid. When the level falls below MIN, refill the reservoir before the bleeding procedure is continued. Failure to maintain a sufficient amount of fluid in the reservoir will result in air in the system.

- D. At this point, perform steps B and C on the FRONT RIGHT bleeder screw; finally, move to the FRONT LEFT bleeder screw and follow the same procedure.



PK104

- E. Repeat steps B and C until the brake pedal is firm.
3. Carefully check the entire hydraulic brake system to ensure all hose connections are tight, the bleed screws are tight, the protective caps are installed, and no leakage is present.

CAUTION

This hydraulic brake system is designed to use DOT 4 brake fluid only. If brake fluid must be added, care must be taken as brake fluid is very corrosive to painted surfaces.

INSPECTING HOSES

Carefully inspect the hydraulic brake hoses for cracks or other damage. If found, the brake hoses must be replaced.

CHECKING/REPLACING PADS

The clearance between the brake pads and brake discs is adjusted automatically as the brake pads wear. The only maintenance that is required is replacement of the brake pads when they show excessive wear. Check the thickness of each of the brake pads as follows.

1. Remove the wheel corresponding to the brake being checked.
2. If the brake pad friction material has worn to the point of the wear groove (A) no longer being visible, replace the brake pads.

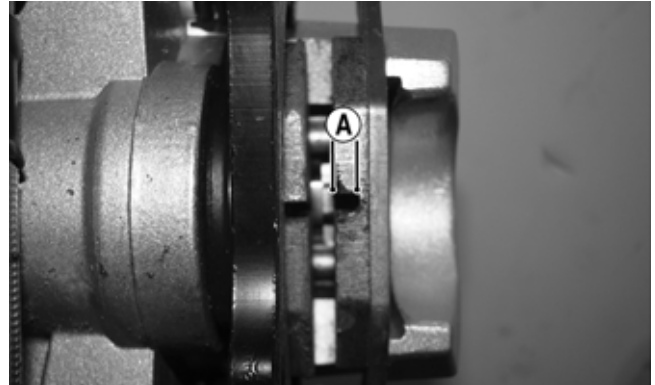

PK105A

■NOTE: For optimum new brake pad life, the brake pads and rotors should be replaced as a set.

To replace the brake pads, use the following procedure:

- A. Loosen the brake pad retaining pins (A); then remove the cap screws securing the caliper holder to the knuckle (B). Remove the retaining pins and pads from the caliper.

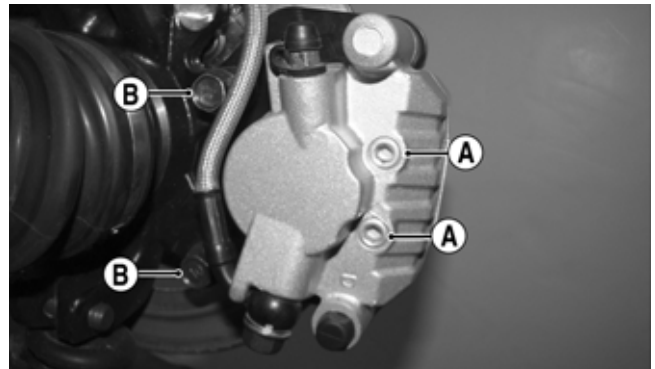

PK106A

- B. Install the new brake pads. Coat the threads of the retaining pins with blue Loctite; then tighten to 13 ft-lb (17.7 N-m).
- C. Secure the caliper holder to the knuckle with new "patch-lock" cap screws. Tighten to 25 ft-lb (34 N-m).

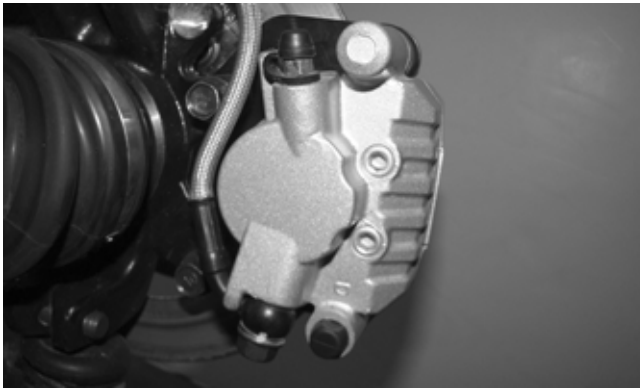

PK106

3. Install the wheels and using a crisscross pattern, tighten the wheel nuts in 20 ft-lb (27.2 N-m) increments to a final torque of 45 ft-lb (61.2 N-m) (steel wheel), 60 ft-lb (81.6 N-m) (aluminum wheel w/black nuts), or 80 ft-lb (108.8 N-m) (aluminum wheel w/ chrome nuts).
4. Burnish the brake pads.

BRAKE DISC

Using a micrometer, measure the thickness of the brake disc in the contact surface. If thickness is 0.125 in. (3 mm) or less, the disc must be replaced. To replace the brake disc, see Drive System – Hub.

Burnishing Brake Pads

Brake pads must be burnished to achieve full braking effectiveness. Braking distance will be extended until brake pads are properly burnished.

⚠ WARNING

Failure to properly burnish the brake pads could lead to premature brake pad wear or brake loss. Brake loss can result in severe injury or death.

1. Choose an area large enough to safely accelerate the vehicle to 30 mph (48 km/h) and to brake to a stop.
2. Accelerate to 30 mph (48 km/h); then release the accelerator pedal and depress the brake pedal to decelerate to 0-5 mph (0-8 km/h).
3. Repeat procedure 20 times until brake pads are burnished.

Checking/Replacing V-Belt

REMOVING

1. Remove the seat and battery storage cover.

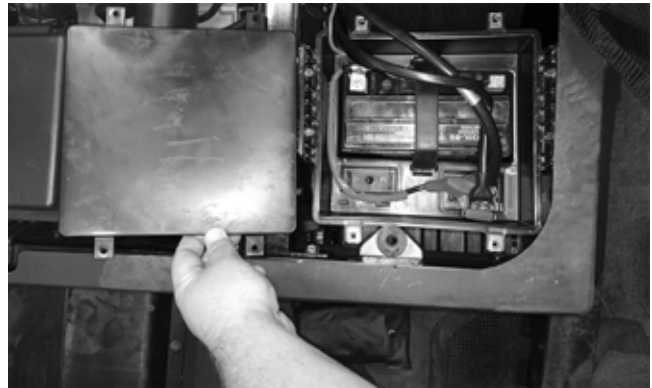

PK050A

2. Remove the battery by disconnecting the negative cable first then the positive cable. Move the starter relay and cables up out of the way. Remove the four cap screws securing the battery box to the frame.

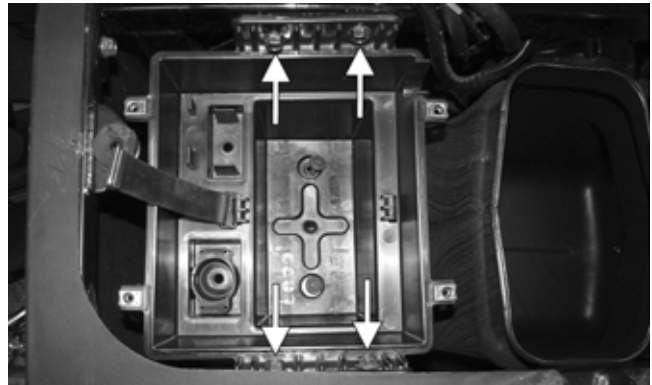

PK107A

3. Remove the reinstallable plastic rivets securing the left rear splash panel; then remove the panel.

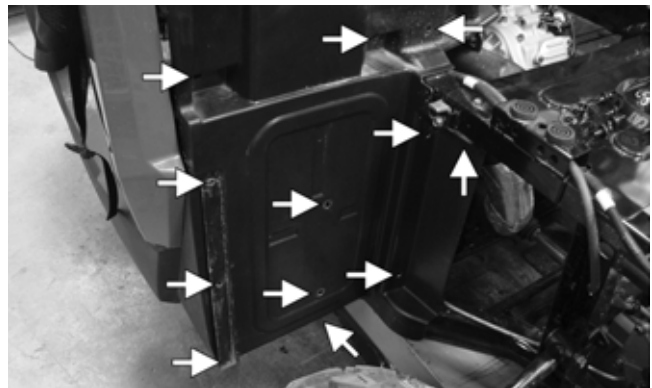

PK108A

4. Loosen the clamp and remove the cap screw securing the CVT exhaust duct to the frame; then remove the duct. Remove the battery compartment assembly through the rear.

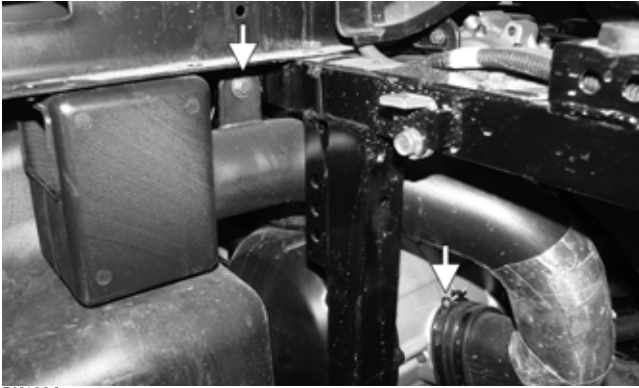

PK109A

5. Note the routing of the throttle cable and position of the clamps securing it. Remove the cap screws securing the CVT cover noting the location of the different-length cap screws for installing purposes; then using a rubber mallet, gently tap on the cover tabs to loosen the cover. Remove the cover. Account for the two dowel pins.

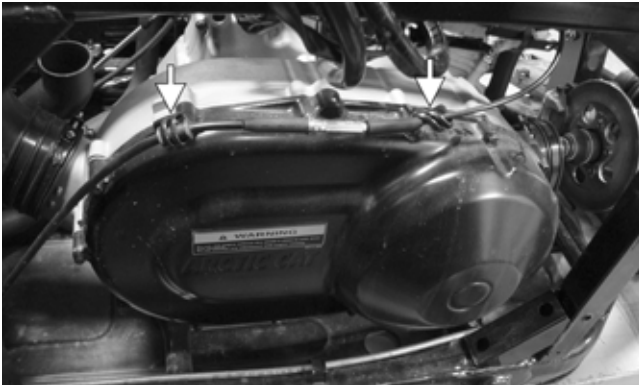

PK111A

6. Remove the nut securing the movable drive face; then remove the face. Account for the spacer.

■NOTE: Keep the drive face plate in contact with the drive face when removing or installing the drive face to prevent the rollers from falling out.

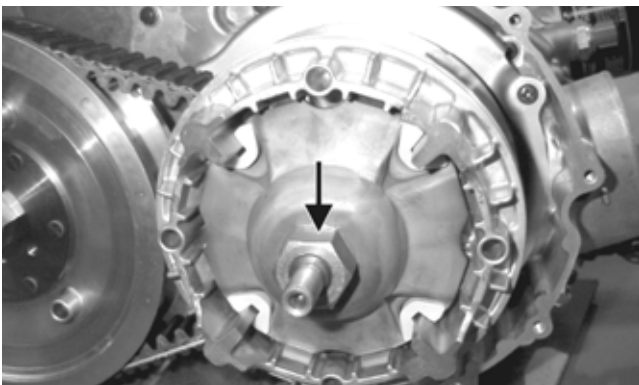

MD1033

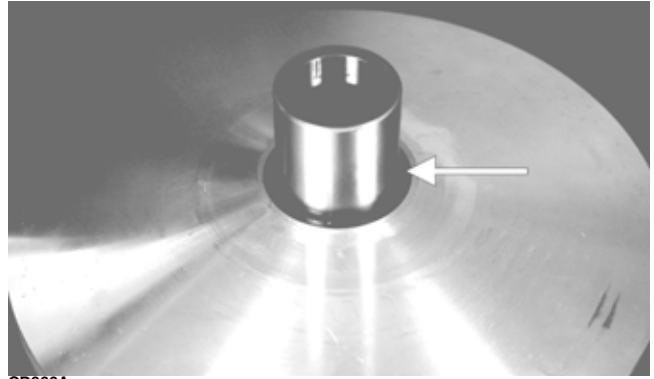

CD966A

7. Install a fully threaded 6 x1 mm cap screw into the driven pulley fixed face; then turn the cap screw clockwise to spread the pulley faces. Remove the V-belt.



KC132

CHECKING

Use Drive Belt Gauge to identify any abnormal wear. Measure across the top of the V-belt (in multiple locations) using a Vernier caliper. Do not squeeze the belt as doing so may produce an inaccurate measurement. The V-belt must be at least 28.5 mm at any point.

INSTALLING

1. Place the V-belt into position on the driven pulley and over the front shaft.

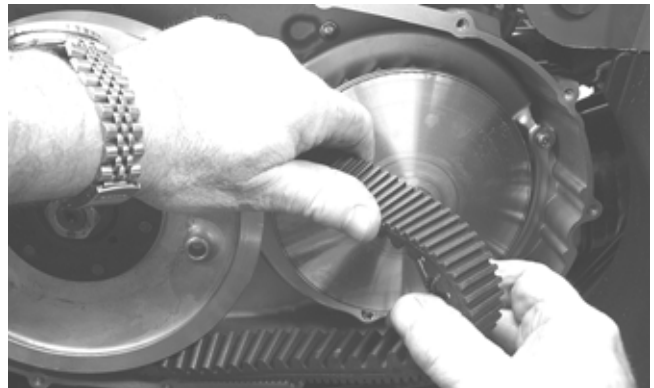

KC136

■NOTE: The arrows on the V-belt should point in direction of engine rotation (clockwise).

2. Pinch the V-belt together near its center and slide the spacer and movable drive face onto the front shaft. Secure the drive face with a new nut. Using an appropriate spanner wrench, tighten the nut to 115 ft-lb (156 N-m).



FI743

CAUTION

Make sure the movable drive face plate is fully engaged onto the splines of the clutch shaft before tightening the nut or false torque readings may occur. This will cause the assembly to loosen damaging the shaft and clutch face plate.

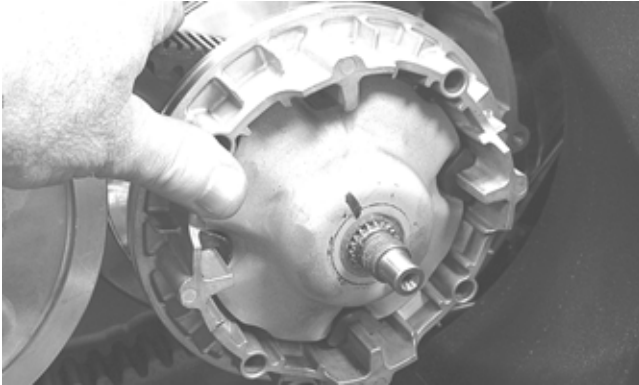

KC138A

■NOTE: At this point, the 6 mm cap screw used to separate the sheaves of the Driven Clutch can be removed.

3. With the vehicle in neutral, rotate the V-belt and clutches counterclockwise until the V-belt is flush with the top of the driven pulley.
4. Place the CVT cover gasket and dowel pins into position. Note the position of the throttle cable routing and clamps; then install the cover and secure with the cap screws making sure the different-length cap screws are in their proper location. Tighten the cap screws to 86 in.-lb (9.7 N-m).

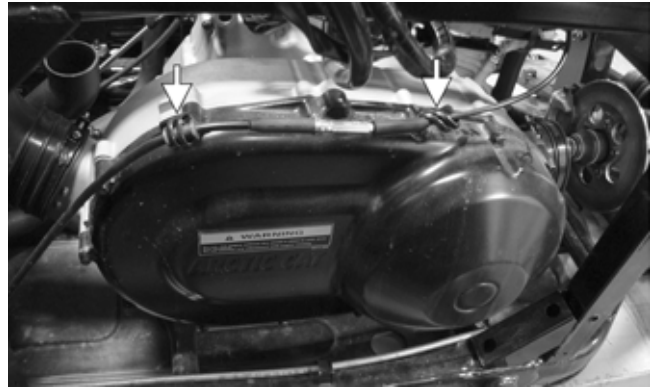

PK111A

5. Install the battery box and storage compartment into the frame. Secure the battery box to the frame; then position the exhaust duct in place. Secure with the cap screw and clamp.
6. Install the left rear splash panel.
7. Install the battery and starter relay. Connect the positive cable first then the negative cable; then install the battery box cover and seat.

Steering/Body/Controls

The following steering components should be inspected periodically to ensure safe and proper operation:

- A. Steering wheel secure.
- B. Steering has equal and complete full-left and full-right turning capability.
- C. Steering sector mounting bolts tight.
- D. Ball joints not worn, cracked, or damaged.
- E. Tie rods not bent or cracked.
- F. Knuckles not worn, cracked, or damaged.
- G. Cotter pins not damaged or missing.
- H. Steering wheel tilt locks securely.

The frame and welds should be checked periodically for damage, bends, cracks, deterioration, broken components, and missing components.

Steering Wheel

REMOVING

1. Remove the steering wheel cover by squeezing the retaining tabs together (located behind the steering wheel); then match mark the steering shaft and steering wheel.

■**NOTE:** Any time steering components are disassembled, all connecting components should be marked for proper alignment during assembling.

2. Remove the nut securing the steering wheel and remove the steering wheel.

INSPECTING

1. Inspect the steering wheel for cracks, missing padding, or broken spokes.
2. Inspect the splines for wear.
3. Check that the steering wheel is not bent.

INSTALLING

1. Install the steering wheel aligning the two match marks. Place the washer onto the steering shaft; then apply a drop of red Loctite #271 to the threads of the nut and secure the steering wheel. Tighten to 25 ft-lb (34 N-m).

■**NOTE:** If a new steering wheel is being installed, mark the wheel as close as possible to the old wheel mark; then check for proper positioning with the front wheels straight forward.



PK112

2. Install the steering wheel cover.
-
-

Steering System

REMOVING STEERING SHAFT ASSEMBLY

1. Remove the steering wheel cover and steering wheel. Account for the washer. Note the match marks for assembly purposes.



PK070A

2. Remove the reinstallable plastic rivets and cap screws securing the plastic steering column covers; then remove both upper and lower covers. Account for the rubber plugs.

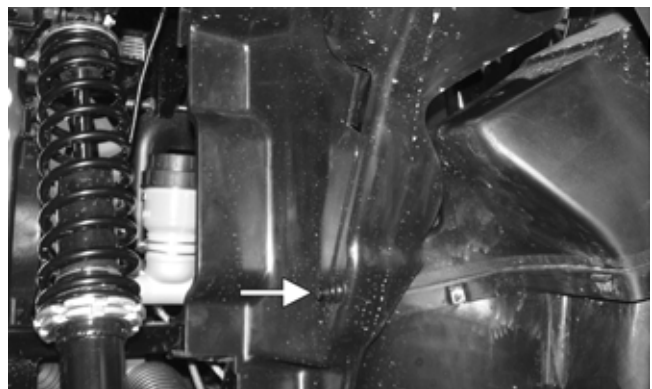

PK113A

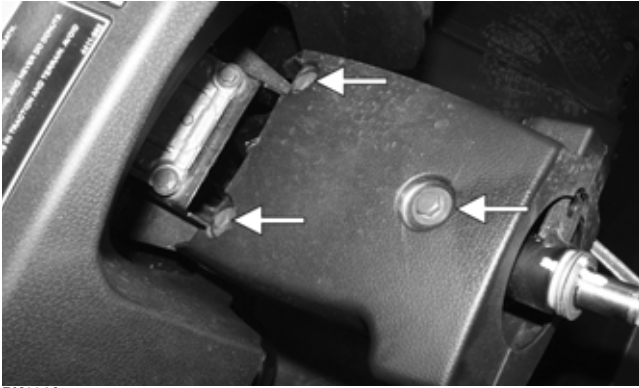

PK114A

3. Remove the steering shaft lift support cap screw and nut. Account for the two spacers.

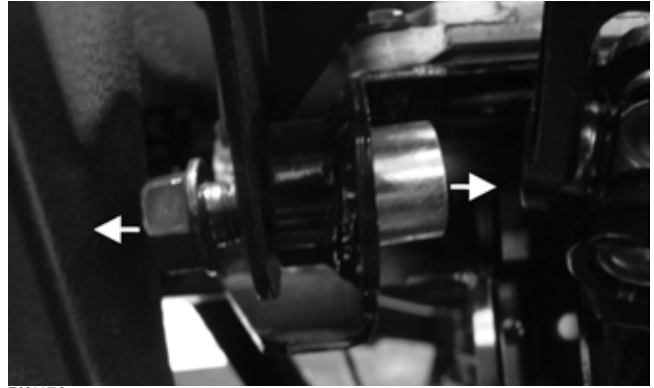

PK117A

6. Note the matching alignment marks on the pinion shaft and rack/pinion housing for assembly purposes.

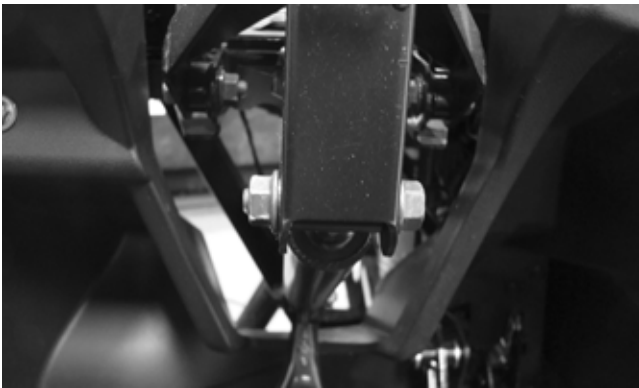

PK115

4. Remove the two nuts securing the cap screws at the steering shaft housing pivot point.

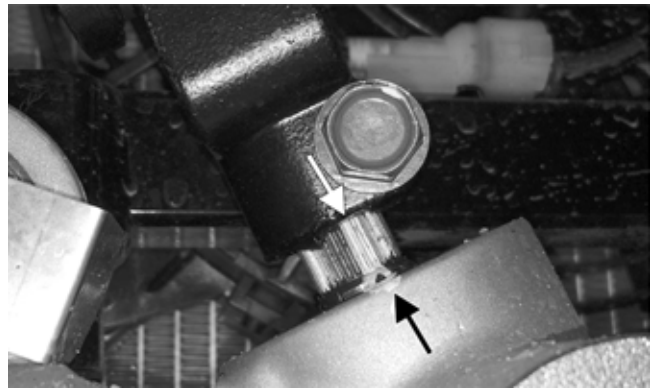

PK118A

7. Remove the cap screw securing the lower steering shaft joint to the pinion shaft; then slide the joint free of the pinion.

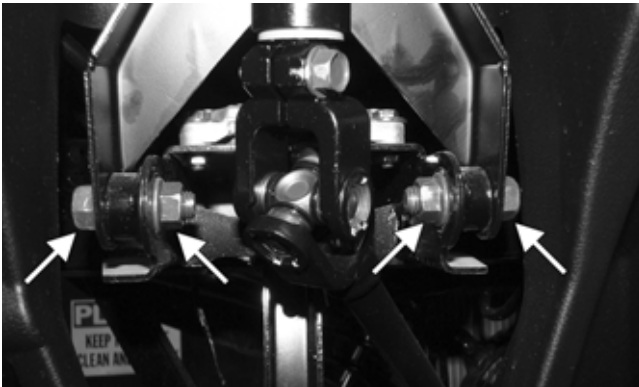

PK116A

5. Remove the two cap screws with washers (located toward the left of the steering shaft housing) securing the dashboard to the frame. Remove the left side steering shaft housing cap screw first; then remove the right. Remove the collars from the inside.

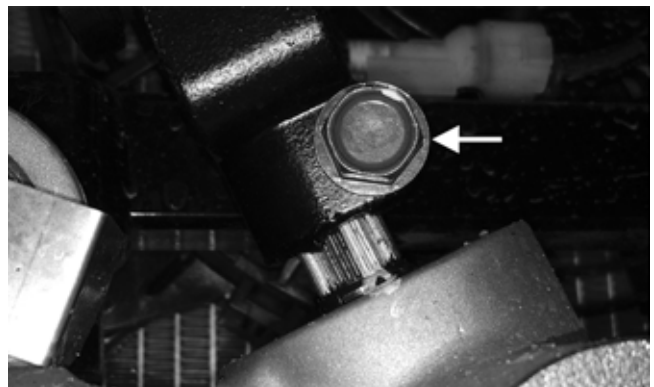

PK118B

8. Align the original marks on the upper steering shaft to the steering column housing.



PK120

9. With the marks still aligned from step 8, on the opposite side of the column, match mark the upper intermediate shaft joint to the bottom of the steering column housing. Remove the cap screw securing the joint to the upper steering shaft; then remove the intermediate steering shaft. Account for the two standard washers and one wave washer.

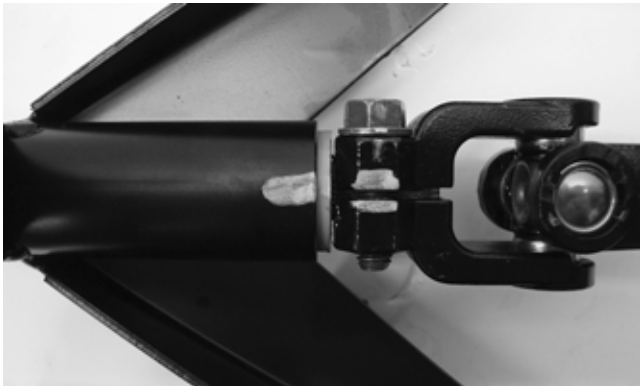

PK119

INSTALLING STEERING SHAFT ASSEMBLY

1. Align the marks on the upper steering shaft to the steering column housing.



PK120

2. Align the gap in the upper intermediate shaft joint to the previously marked location on the steering column housing. Secure with the cap screw; then tighten to 15 ft-lb (20.4 N-m).



PK119

3. Align the match marks on the splined pinion shaft to the marks on the rack/pinion housing.

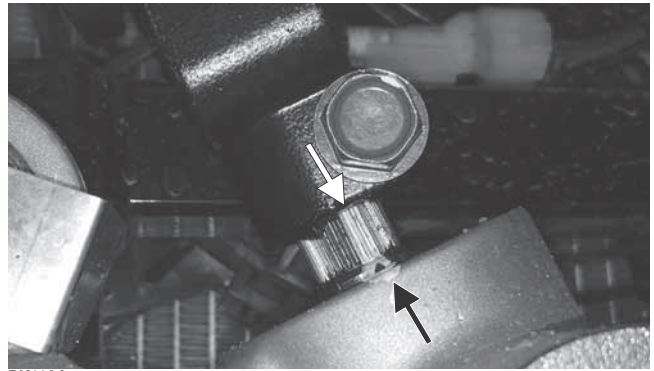

PK118A

4. With the marks still aligned from the upper steering shaft to the steering column housing, place the lower intermediate shaft joint onto the splined pinion shaft of the rack/pinion assembly. Tighten the cap screw to 15 ft-lb (20.4 N-m).

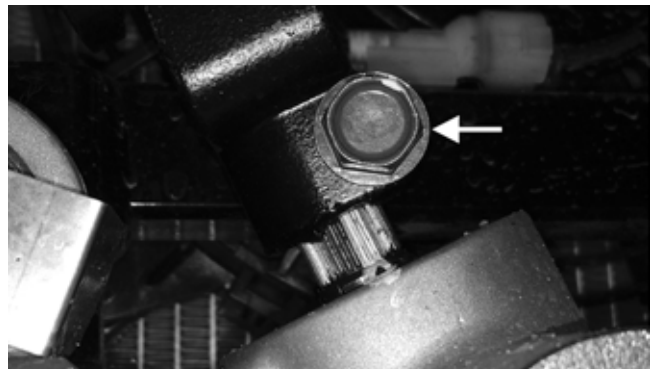

PK118B

5. Place the cap screws into position; then install each spacer into the frame. Install the steering shaft housing. Secure to the frame with two cap screws and nuts. Tighten to 23 ft-lb (31.3 N-m).

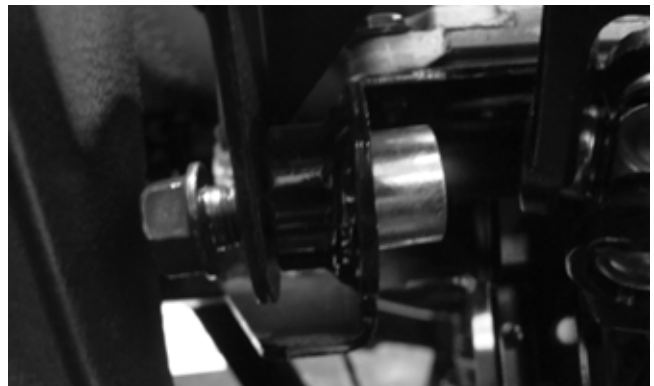

PK117

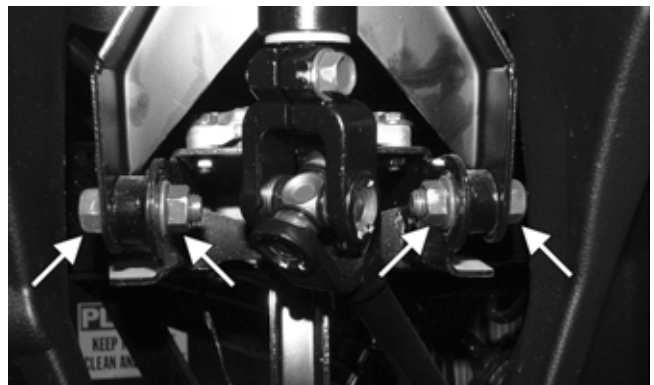

PK116A

- With the spacers in place, secure the lift support to the steering column using the cap screw and nut. Tighten securely.

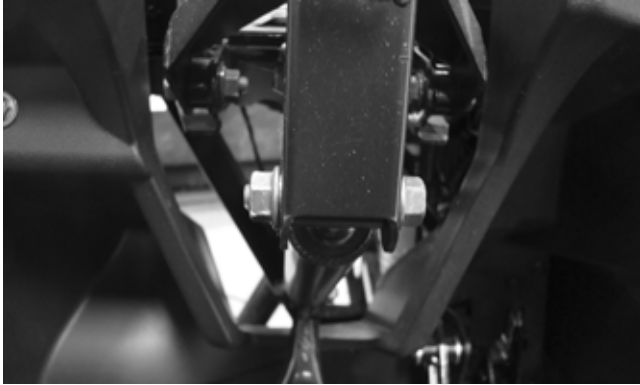

PK115

- Install both upper and lower steering column covers and secure using the cap screws and reinstallable inserts. Insert the rubber plugs into the covers.
- Install the steering wheel (see Steering Wheel in this section).

REMOVING RACK AND PINION

- Remove the steering shaft; then remove the front wheels.
- Remove the cotter pins and castle nuts securing the tie rod ends to the knuckle. Account for the washers; then remove the tie rod ends from the knuckles.



PK121

- Remove the cap screws securing the steering rack assembly to the frame and remove from the left side.

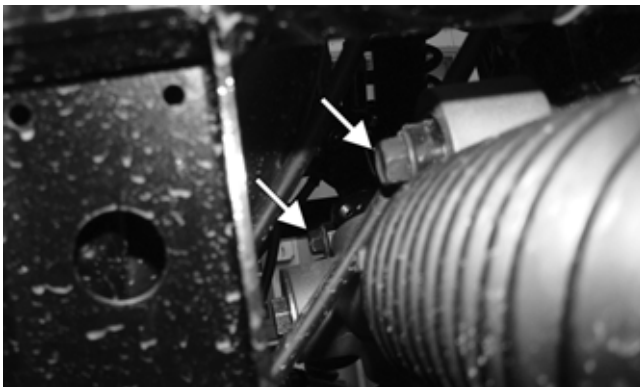

PK122A

INSPECTING RACK AND PINION

- Inspect the tie rod ends for damaged threads, torn boots, or excessive wear.
- Inspect the tie rods for bends or deformation.
- Inspect the rack and pinion-to-tie rod boots for tears or deterioration.



PR785

- Verify the cable ties for each boot are secure and in good condition. Replace if necessary.
- Check that the steering assembly operates smoothly with no binding from full-left to full-right position.
- Inspect for grease seepage from the steering assembly.

■NOTE: The steering assembly (rack and pinion) is not repairable and must be replaced as an assembly; however, the tie rods and boots are replaceable.

INSTALLING RACK AND PINION

- From the left side, install the steering assembly (rack and pinion) to the frame assembly and secure with two cap screws. Tighten to 34 ft-lb (46.2 N-m).
- Place the tie rod ends into the knuckles. Install the washers; then secure with the castle nuts (coated with red Loctite #271). Tighten to 25 ft-lb (34 N-m); then install new cotter pins.

■NOTE: If the slots in the castle nut are not aligned with the hole in the tie rod end, tighten until the cotter pin can be installed.

- Install the steering shaft (see INSTALLING STEERING SHAFT ASSEMBLY).
- Install the wheels and using a crisscross pattern, tighten the wheel nuts in 20 ft-lb (27.2 N-m) increments to a final torque of 45 ft-lb (61.2 N-m) (steel wheel), 60 ft-lb (81.6 N-m) (aluminum wheel w/black nuts), or 80 ft-lb (108.8 N-m) (aluminum wheel w/chrome nuts).

REMOVING TIE RODS

- Remove the steering rack assembly (see REMOVING RACK AND PINION in this section).
- Support the steering rack assembly in a suitable holding fixture or bench vise; then cut the securing band and slide the boot toward the outer tie rod end.
- Using a punch or chisel, bend the lock washer away from the flats on the tie rod joint.



PR780

- Using an appropriate crowfoot and backing wrench, remove the tie rod assembly.

■NOTE: Tie rods come as a complete assembly. No further disassembly is required.

- Remove and discard the lock washer.

INSTALLING

- Remove the tie rod end and lock nut from the tie rod; then install the tie rod boot onto the tie rod.
- Install the tie rod lock nut and tie rod end.
- Coat the tie rod joint threads with red Loctite #271; then with a new lock washer, thread the tie rod into the rack.



PR784

- While holding the rack shaft with a wrench, tighten the tie rod joint to 37 ft-lb (50.3 N-m) using an appropriate crowfoot wrench.



PR781

■NOTE: Always attach the crow-foot to the torque wrench with the open end 90° to the torque wrench handle to ensure accurate torque application.

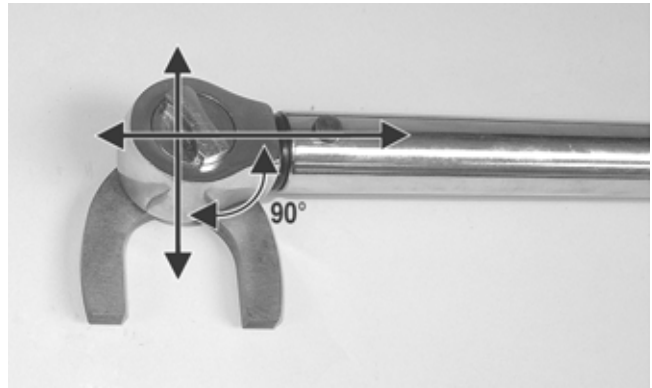

PR528A

- Install the boot onto the rack and secure with the nylon tie.
- Center the rack in the steering rack assembly and align the white paint line on the pinion with the mark on the rack housing.



PR785A

Steering Knuckles

REMOVING AND DISASSEMBLING

- Secure the vehicle on a support stand to elevate the wheel; then remove the wheel.

⚠ WARNING

Make sure the vehicle is solidly supported on the support stand to avoid injury.

- Remove the cotter pin and nut securing the hub.
- Remove the brake caliper.
- Remove the hub assembly; then remove the brake line from the knuckle.
- Remove the cotter pin from the tie rod end and remove the tie rod end from the knuckle. Account for the washer.
- Remove the two cap screws securing the ball joints in the knuckle.



PK123A

7. Tap the ball joint end out of the knuckle; then remove the knuckle.
8. Using a suitable seal puller, remove both seals from the knuckle. Note the two different seals.



PK124

9. Remove the snap ring securing the bearing in the knuckle; then press the bearing out of the knuckle.



PK125

CLEANING AND INSPECTING

1. Clean all knuckle components.
2. Inspect the bearing for pits, scoring, rusting, or premature wear.
3. Inspect the knuckle for cracks, breaks, or galling of the bearing surface.

ASSEMBLING AND INSTALLING

1. Using a suitable press and driver, press the bearing into the knuckle until firmly seated; then install the snap ring.



PK126



PK125

2. Grease the bearing and seals; then using a suitable sized seal driver, install both inner and outer seals. The large lipped seal installs into the inner side of the knuckle.
3. Install the knuckle to the upper and lower ball joints and secure with the two cap screws. Tighten to 35 ft-lb (47.6 N-m).



PK123

4. Install the tie rod end onto the knuckle; then install the washer and secure with the nut (coated with red Loctite #271). Tighten to 30 ft-lb (40.8 N-m); then install a new cotter pin and spread the pin.

■**NOTE:** During assembling, new cotter pins should be installed.

5. Apply a small amount of molybdenum grease to the hub splines.

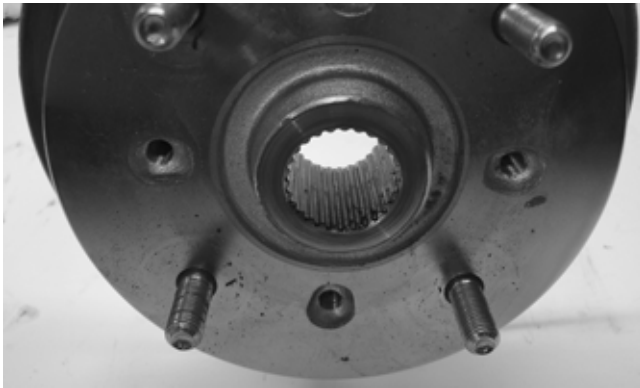

PK127

6. Install the hub assembly onto the splines of the shaft.

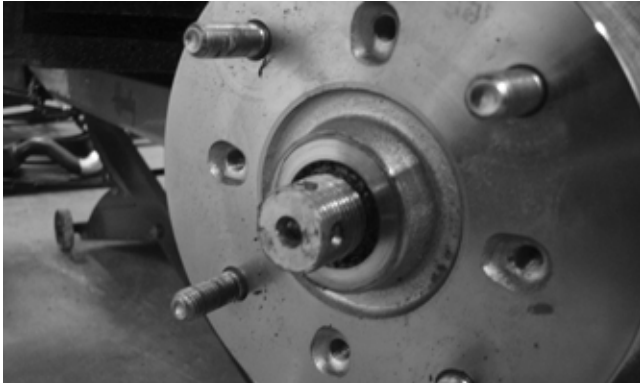

PK128

7. Using Hub Retaining Wrench, secure the hub assembly with the nut. Tighten to 200 ft-lb (271.2 N-m).



PK129

8. Install a new cotter pin.

■NOTE: If necessary, further tighten the hub nut clockwise to allow the installation of a new cotter pin.



PK130

9. Secure the brake line to the knuckle; then secure the brake caliper to the knuckle with the two new “patch-lock” cap screws. Tighten to 20 ft-lb.

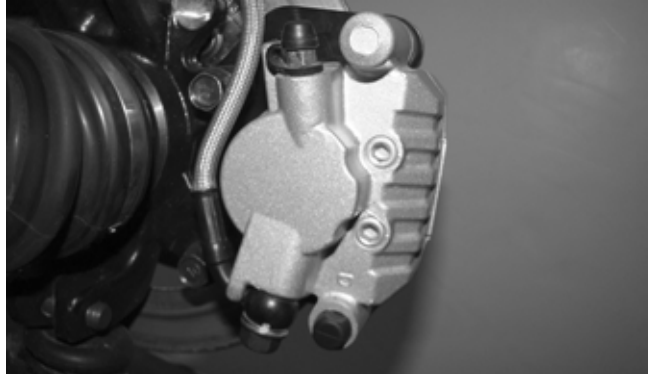

PK106

10. Install the wheels and using a crisscross pattern, tighten the wheel nuts in 20 ft-lb (27.2 N-m) increments to a final torque of 45 ft-lb (61.2 N-m) (steel wheel), 60 ft-lb (81.6 N-m) (aluminum wheel w/black nuts), or 80 ft-lb (108.8 N-m) (aluminum wheel w/ chrome nuts).

11. Remove the vehicle from the support stand.

Accelerator Pedal

REMOVING

Release the return spring (A) from the accelerator pedal, then remove the throttle cable from the pedal. Remove the E-clip (B); then remove the pedal. Account for the washers (C).

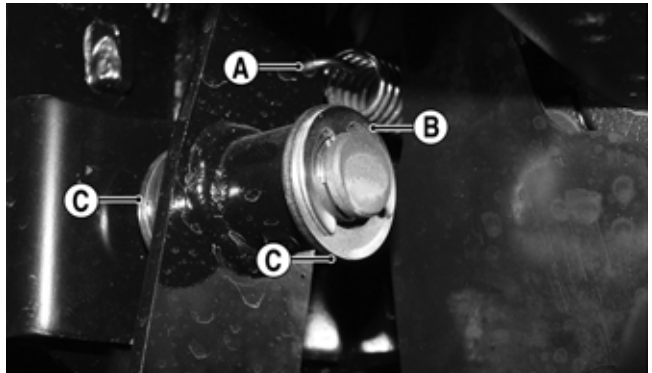

PK131A

INSTALLING

Place one washer into position. Install the pedal and then the second washer. Secure with a new E-clip. Install the throttle cable and return spring to the pedal.

CAUTION

Check for smooth accelerator cable operation. Verify the pedal returns to the idle position.

Shift Lever

REMOVING

■NOTE: The dash must be removed prior to replacement of the shift lever (see Dashboard).

1. Remove the E-clip (A) and washer (B) connecting the shift cable to the shift lever. Account for the bushing (C).

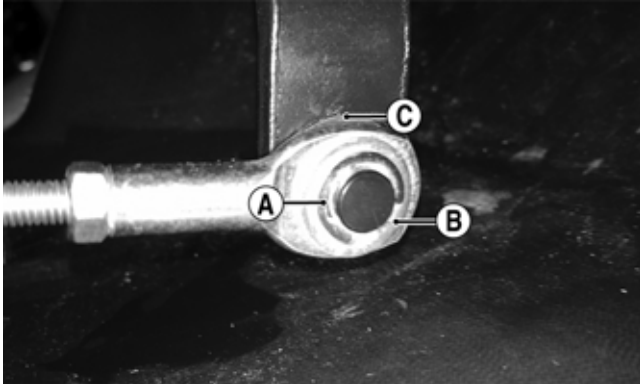

PK132A

2. Remove the cap screw (A) and washer securing the shift guide (B) to the shift lever shaft. Remove the guide and shift lever (C). Account for the three washers.

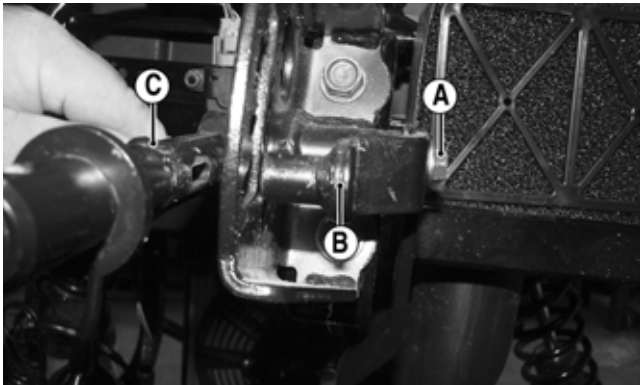

PK133A

INSTALLING

1. Place one larger outside diameter washer onto the shift lever shaft then grease; then slide the shift lever shaft into the frame.
2. Place a second larger outside diameter washer onto the shift lever shaft; then install the shift guide onto the shift lever shaft. Secure using a new patch lock cap screw with the smaller outside diameter washer.

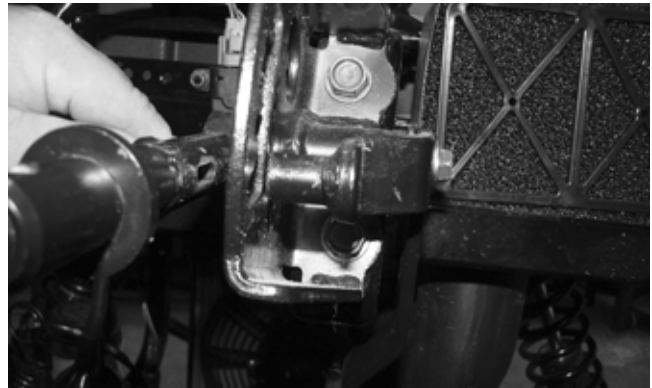

PK133

3. With the bushing (C) in place on the shift lever shaft, install the shaft cable. Secure it with a washer (B) and a new E-clip (A).

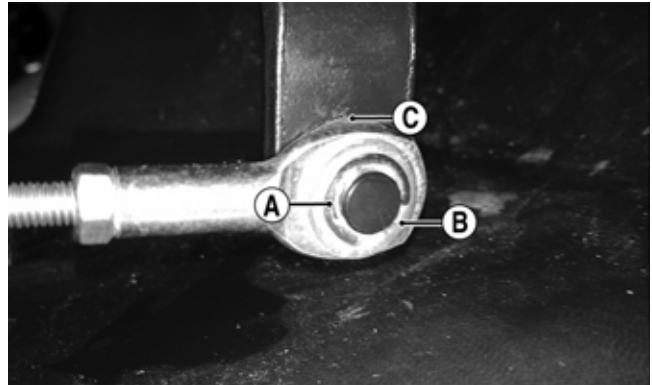

PK132A

4. Install the dashboard (see Dashboard).
5. Check for proper shifter operation (see Periodic Maintenance/Tune-Up — Shift Cable).

Shift Cable

REMOVING

1. Remove the seat; then remove the plastic rivet securing the front left inner fender panel. Remove the panel.

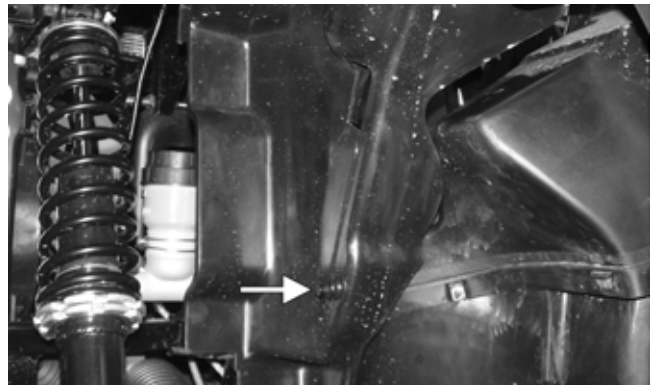

PK134A

2. From under the dash, remove the E-clip securing the shift cable end to the shift lever guide. Account for the washer and bushing.

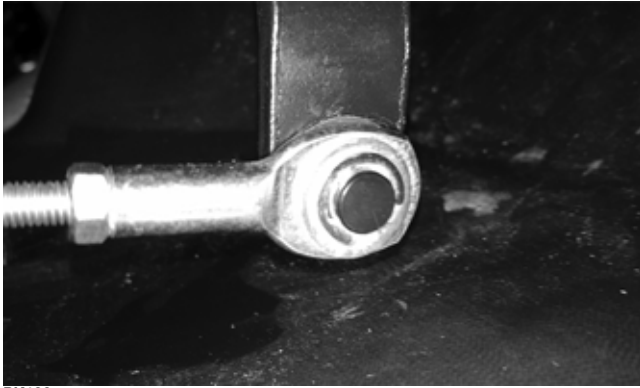

PK132

3. From under the front body panel, measure the installed length of the threads; then loosen the cable adjuster nuts. Slide the cable out of the bracket.

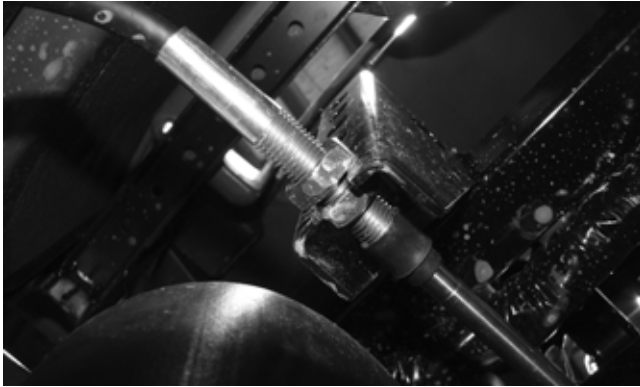

PK101

4. From under the seat, remove the E-clip (A) securing the cable end to the shift arm stud. Account for the washer (B) and bushing (C).

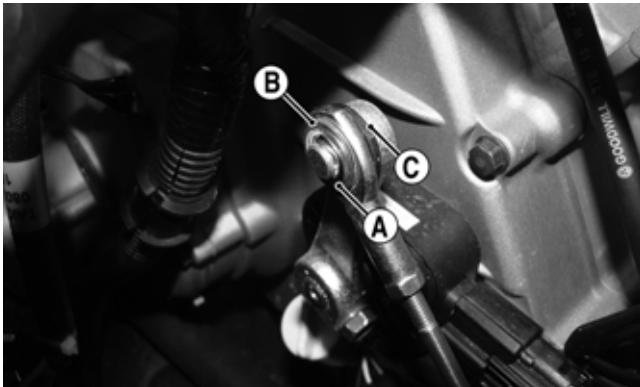

PK100A

5. Measure the installed set length of the threads; then loosen the adjuster nuts. Remove the shift cable from the bracket.
6. Remove the center floorboard panel and any cable ties securing the shift cable to the chassis noting their location; then remove the shift cable.



PK102

■NOTE: If the cable is being replaced, connect the new cable to the end of the existing cable and pull the new cable into place.

INSTALLING

1. Route the cable into position making sure there are no kinks or sharp bends.
2. Guide the shift cable into the shift cable bracket. Install the cable end to the shift arm stud and secure with a new E-clip. Using the measured length (from step 5), install the shift cable into the bracket; then secure the adjuster nuts.



PK100

3. From under the front body panel, guide the shift cable into the bracket; then using the measured length (from step 3), secure the adjuster nuts to the bracket. Install the cable end to the shift lever attachment using a new E-clip. Tighten each nut to secure the cable to the bracket.
4. Fasten the shift cable to the chassis with the previously identified cable tie locations.
5. Shift the transmission through all positions making sure the each gear position illuminates the appropriate gears selected and that Park Indicator illuminates only when fully in Park. Adjust as necessary.
6. Install the center floorboard panel, front right access panel, and seat.

LCD Gauge

REMOVING/INSTALLING

To remove the gauge, pull out on one side of it; then disconnect the multi-pin connector and remove the gauge.



PK135

To install the gauge, connect the multi-pin connector and press the gauge into the dash.

■NOTE: Ensure the rubber mounting ring is oriented correctly on the tab and seats fully through the dash.

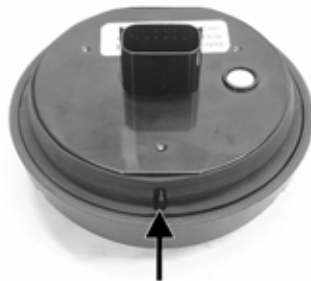

WT601A

Front Wheel Alignment

■NOTE: All measurements and adjustments must be made with the vehicle unloaded.

Mark the centerline of the front tires at the front and rear of the tire; then using a tape measure, measure and record the distance between the marks at the front and rear. The front measurement should be 0-6 mm (0-1/4 in.) greater than the rear measurement (toe-out).



PR087A

1. Center the steering wheel; then using an open-end wrench to hold the tie rod ends (A), loosen the right-side and left-side jam nuts (B).



TXR002B

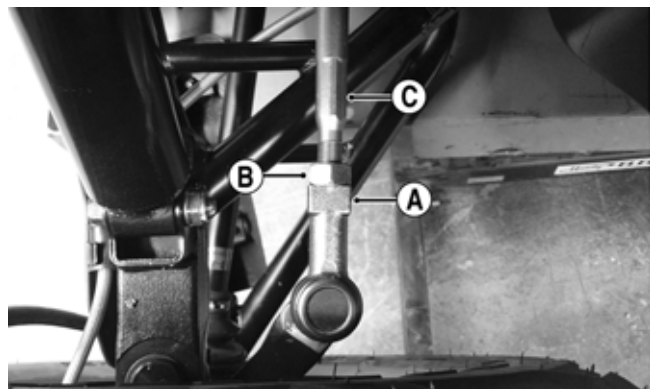

PK079A

CAUTION

Always use a wrench to hold the tie rod ends when loosening or tightening the jam nuts or damage to the boots could occur.

2. Turn the left-side and right-side tie rods (C) in equal increments to achieve the proper toe-out; then tighten the jam nuts to 28 ft-lb (38.1 N-m).

Front Fascia/Front Bumper

REMOVING

1. Remove the eight cap screws securing the lower front fascia to the frame from both sides of the vehicle; then remove the lower fascia.

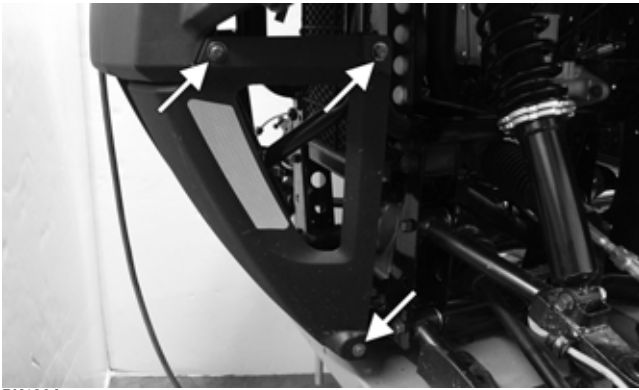

PK136A

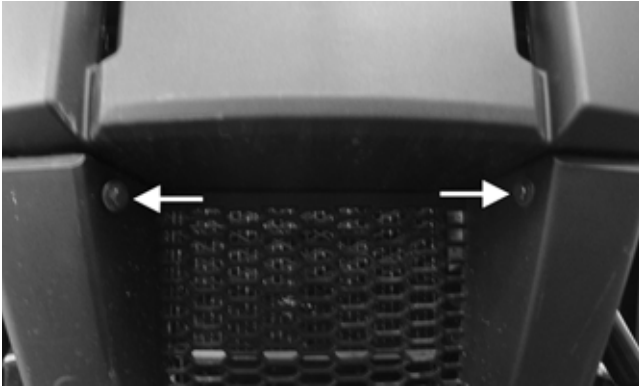

PK137A

2. Remove the two cap screws at the front of the upper fascia secured to the frame; then remove the cap screws securing the upper fascia from around the headlights.

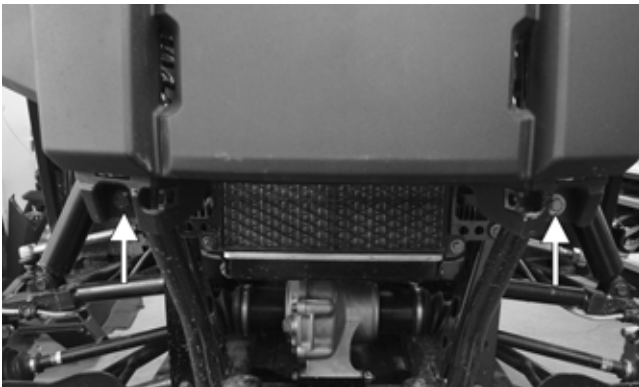

PK139A

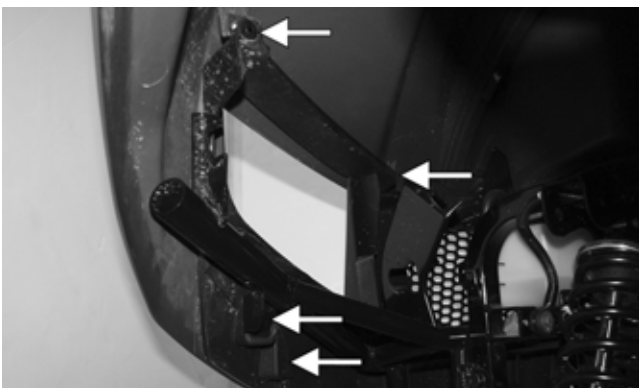

PK138A

3. Remove the two remaining machine screws; then separate the upper fascia from the front body panel for removal.

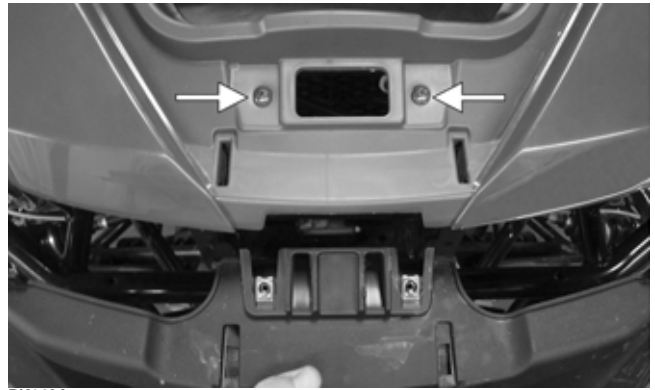

PK140A

4. Disconnect both headlight assemblies; then remove the cap screws securing the bumper to the frame from both sides of the vehicle. Remove the bumper.

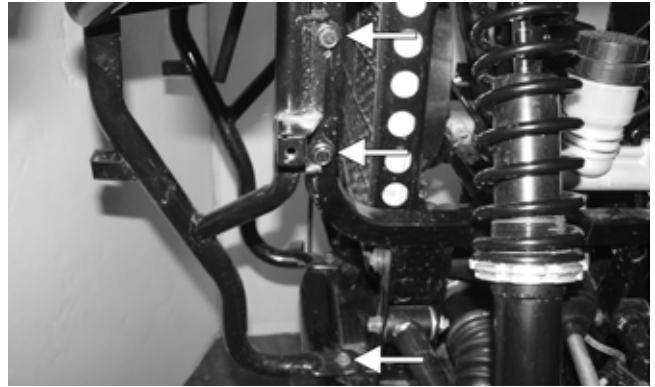

PK141A

5. Remove the two Z-shaped retaining clips securing each side of the headlights to the bumper; then remove the tilt adjust knob.

INSTALLING

1. With the headlights installed, place the front bumper into position and secure the cap screws. Tighten to 22 ft-lb (29.9 N-m). Connect each headlight connector.

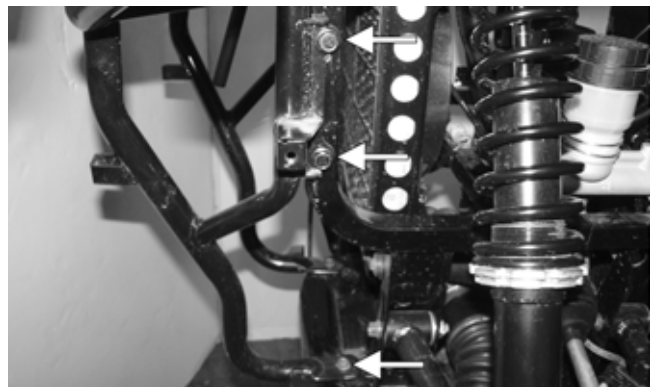

PK141A

2. Place the upper fascia into position and secure the cap screws.

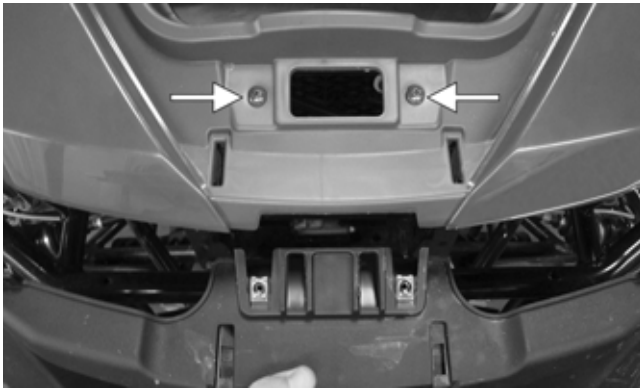

PK140A

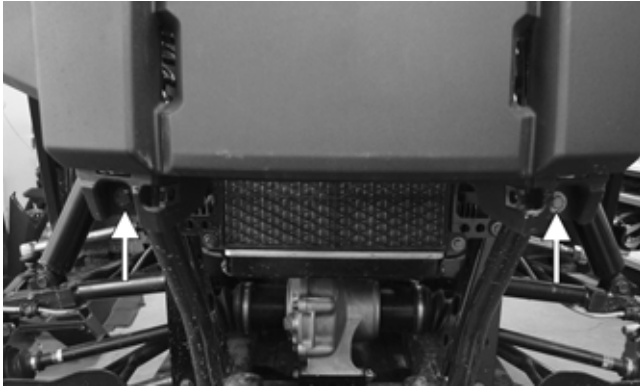

PK139A

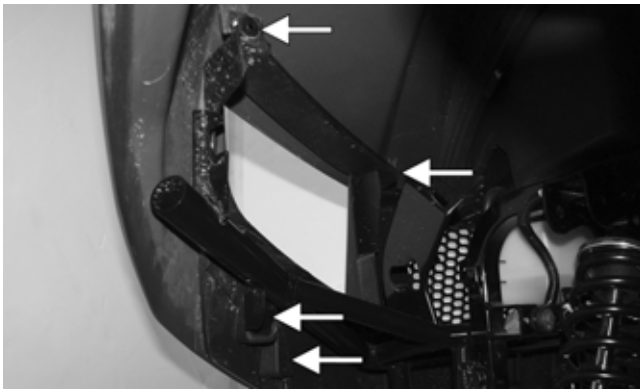

PK138A

3. Secure and install the lower fascia to the frame using the cap screws.

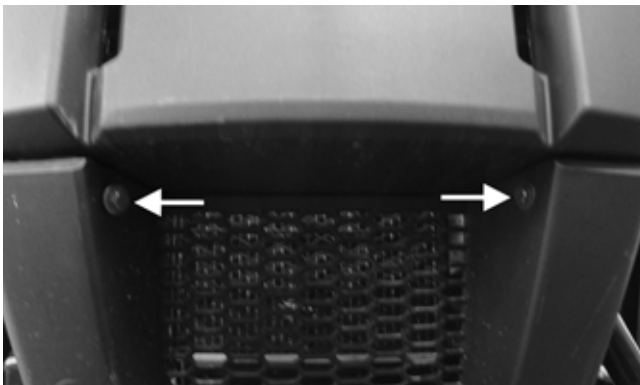

PK137A

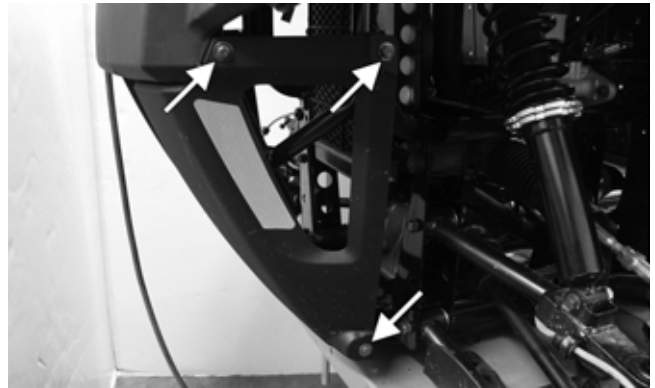

PK136A

4. Check and adjust headlight aim (see Headlight — Taillight/ Brake Light — Reverse Light section).

Hood/Front Storage Compartment

To access the front storage compartment, lift up firmly on the front of the hood to remove. To install, align the tabs of the hood into the front panel slots and press down firmly to secure.



PK084

Front Body Panel

REMOVING

1. Remove the front fascia (see Front Fascia/Front Bumper section); then remove both side panel assemblies (see Dashboard — step 5).
2. With assistance remove the cap screws and nuts securing the front half of the ROPS assembly; then remove. Discard the cap screws and nuts.

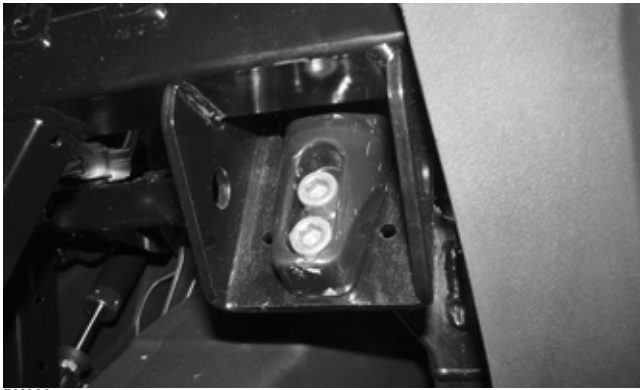

PK069



PK143



PK089

3. Remove the eight plastic rivets securing the top of the dashboard to the front body panel; then separate the panel from the dash.
4. Remove the front access panel; then remove the PDM (A) and diagnostic plug (B) from the body panel. Remove the two remaining cap screws securing the body panel to the frame.

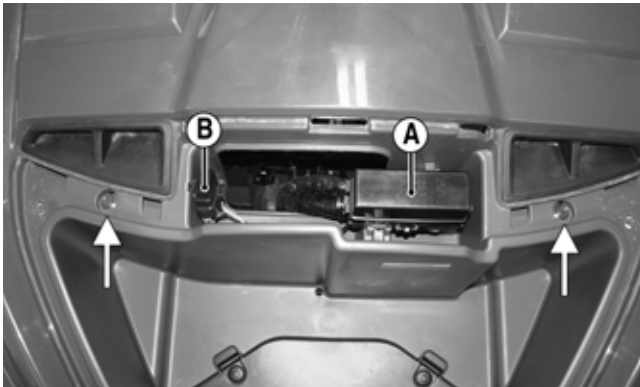

PK144A

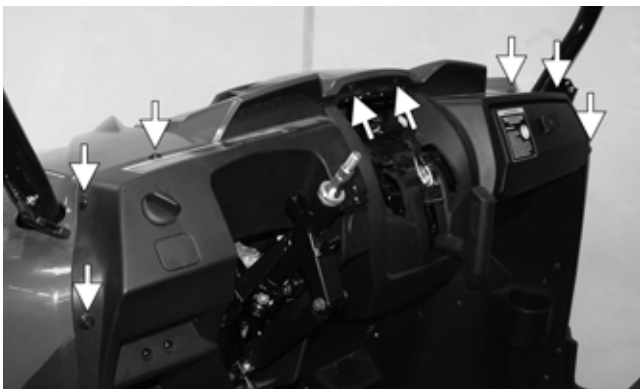

PK142A

INSTALLING

1. Install the front body panel; then secure it to the top of the dashboard using the plastic rivets. Place the PDM and diagnostic plug into position; then using the two cap screws, secure the panel to the frame.

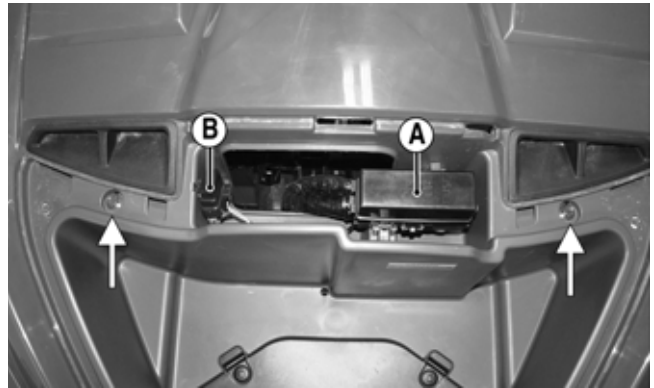

PK144A

2. Install the front fascia (see Front Fascia/Front Bumper) and both side panel assemblies (see Dashboard — step 5).
3. Using new cap screws and nuts and with assistance, install the front half of the ROPS assembly. Finger tighten all fasteners first; then tighten to 47 ft-lb (63.9 N-m).

Floor

REMOVING

1. Remove the dashboard (see Dashboard).
2. Remove the cap screws and plastic rivets securing the center foot guard. Remove the guard.

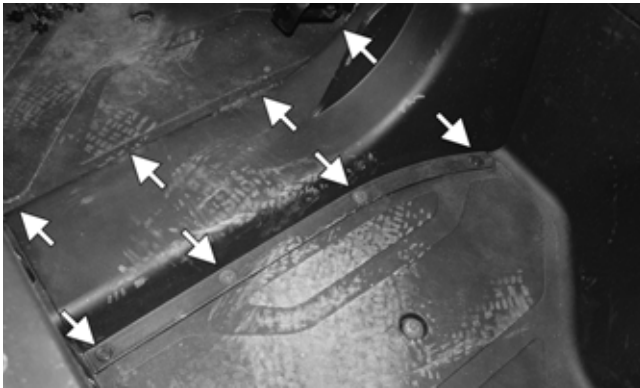

PK145A

3. Remove the accelerator pedal (see Accelerator Pedal in this section).
4. Remove the cotter pin and clevis pin securing the master cylinder plunger to the brake pedal lever. Remove the E-clip (A) securing the brake pedal lever to the bracket. Release the return spring (C). Remove the brake lever and account for the washers (B).

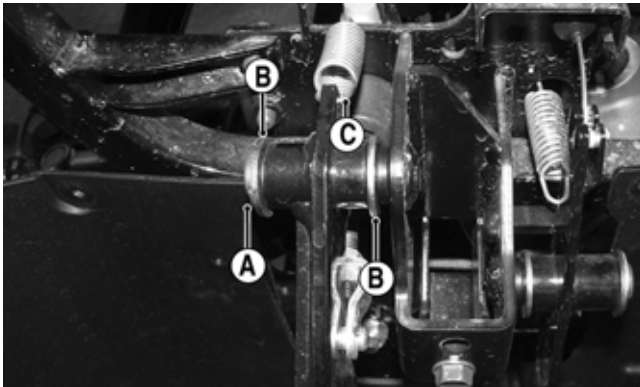

PK147A

5. Remove the cap screws (A) and plastic rivets (B) to remove both left and right side panel assemblies.

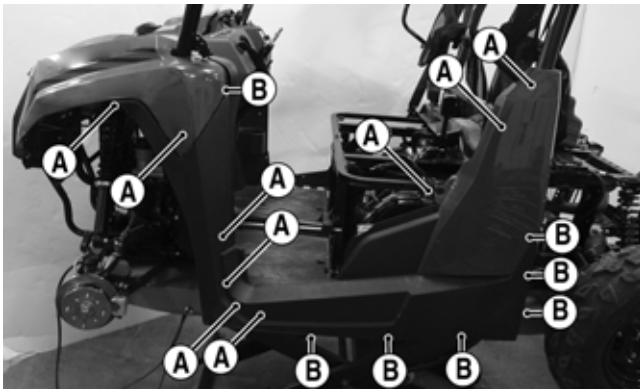

PK093B

■ **NOTE:** To remove the right side panel assembly, the gas tank cap and an additional plastic rivet, located behind the right-rear ROPS tube securing the rear splash panel to the side panel, must be removed.

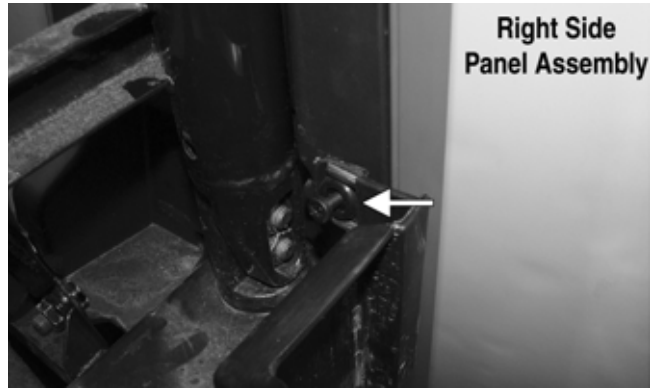

PK148A

Right Side
Panel Assembly



PK146

6. Remove the remaining cap screws securing the floor board to the frame from each side of the vehicle.

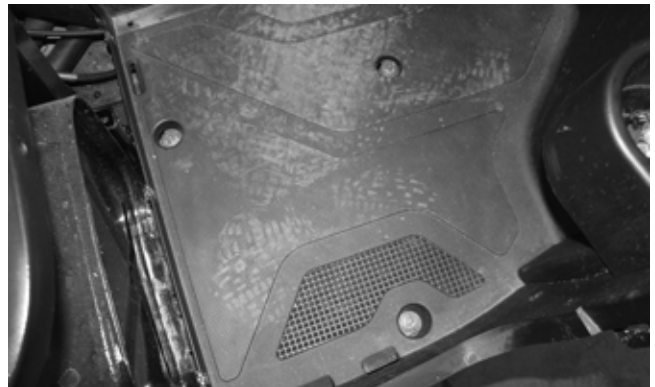

PK149

7. Remove the floorboard.



PK150

CLEANING AND INSPECTING

1. Clean the floor with soap and water.
2. Inspect the floor for cracks or holes.

INSTALLING

1. Place the front of the floor into position in the vehicle first; then lower the rear and push down into position.
2. Secure the floor with the cap screws.
3. Install the accelerator and brake pedals using new E-clips. Additionally, use a new cotter pin when securing the clevis pin of the master cylinder push rod.
4. Install the center foot guard; then install the dashboard (see Dashboard).

Dashboard

REMOVING

1. Remove the seat, steering wheel, shift lever handle, and steering column covers.
2. Remove the cap screws and plastic rivets securing the engine compartment panel to the frame; then remove the panel.

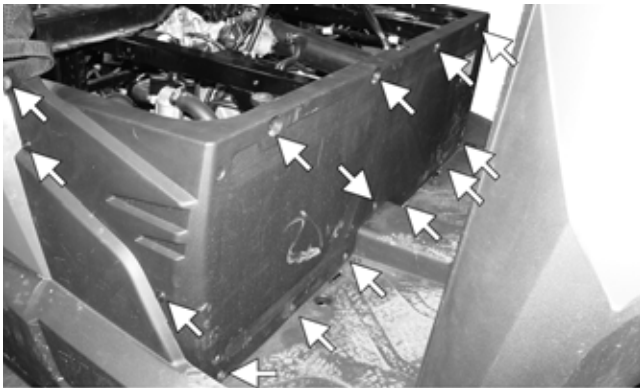

PK151A

3. Remove and disconnect the instrument gauge; then remove the four Allen-head cap screws securing the center dash panel. Remove the ignition switch from the panel; then disconnect the 2WD/4WD switch, override switch, and accessory plug.

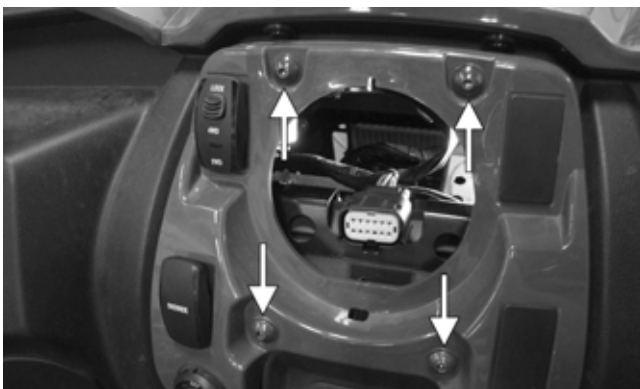

PK152A

4. Remove the plastic rivets securing the rubber splash guard from behind the accelerator and brake pedals; then remove the guard.



PK153A

5. From under the dash, disconnect the light switch connector; then remove the female side of the connector from the frame.

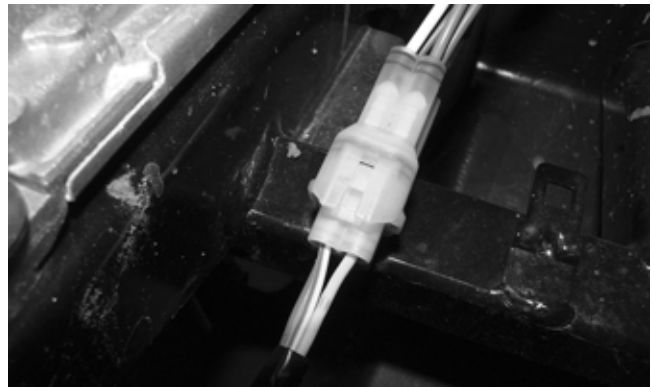

PK154

6. Remove the cap screws (A) and plastic rivets (B) to remove both left and right side panels.

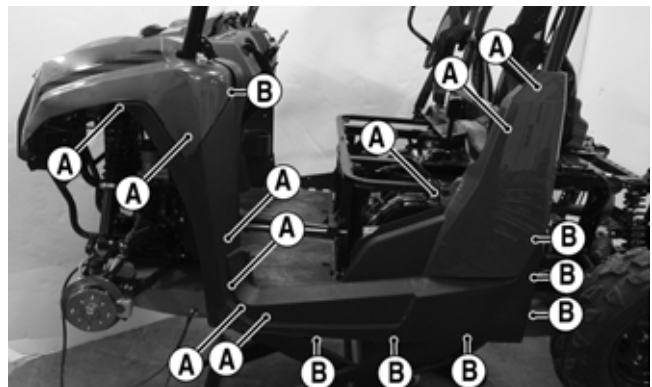

PK093B

■ **NOTE:** To remove the right side panel assembly, the gas tank cap and an additional plastic rivet, located behind the right-rear ROPS tube securing the rear splash panel to the side panel, must be removed.



Right Side
Panel Assembly

PK148A

7. Remove the cap screws and plastic rivets securing the dashboard to the front body panel and frame; then separate the top of the dash from the front body panel.

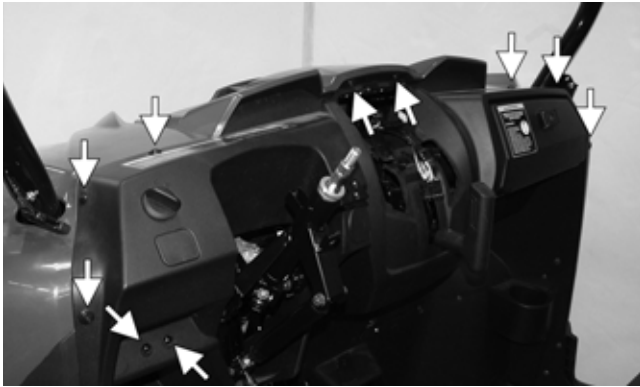

PK142B



PK143

8. Remove the two remaining cap screws securing the bottom of the dash to the floorboard panel. Remove the dashboard.



PK155

INSTALLING

1. To aid in installation of the dashboard, remove the bottom of the lift support from the steering column via the cap screw and nut. Account for the bushing. Tilt the lift support out; then install the dashboard into position.



PK156

2. Install the bushing; then secure the bottom of the lift support to the steering column via the cap screw and nut. Tighten securely.
3. Install and secure the two cap screws located toward the outside edges of the dash to secure to the floorboard.



PK155

4. Install the left and right side panel assemblies using cap screws (A) and plastic rivets (B).

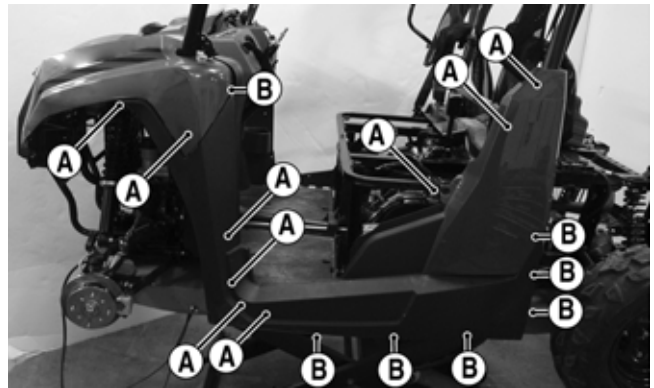

PK093B



PK148A

5. Align the top of the dashboard with the front body panel; then using eight plastic rivets and two cap screws, secure the dash to the front body panel and frame.

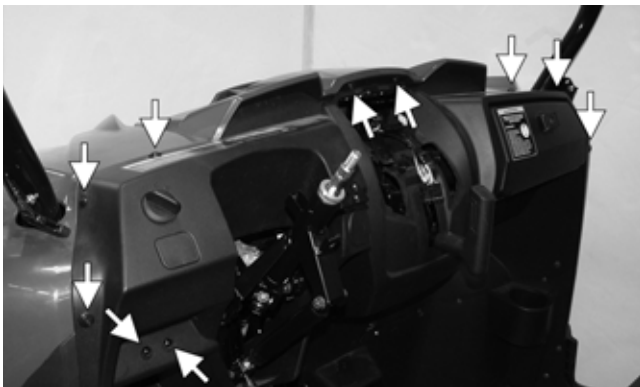

PK142B

6. Connect the headlight switch connector and install the ignition switch to the center dash panel. Place the center dash panel into position and connect the 2WD/4WD switch, override switch, ignition switch, and 12V accessory outlet. Secure the center dash panel to the dashboard with the four Allen-head cap screws.

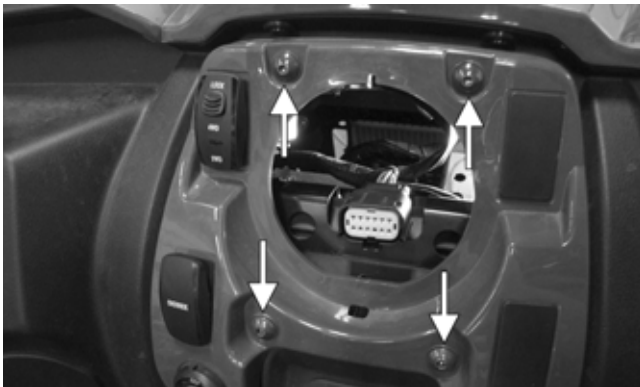

PK152

7. Install the gauge, shift lever handle, and steering column covers.
8. Align and install the steering wheel (see Steering Wheel in this section). Tighten to 25 ft-lb (34 N-m). Install the steering wheel cover.

Belly Panel

REMOVING

1. Remove the body screws securing the belly panel to the underside of the frame.
2. Remove the belly panel.

INSTALLING

1. Place the belly panel into position on the underside of the frame.
 2. Install the body screws. Tighten securely.
-
-

Muffler

REMOVING

1. Remove the two exhaust springs at the muffler/exhaust pipe juncture.

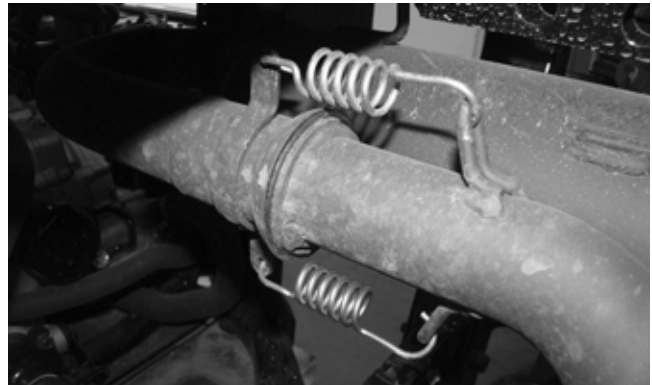

PK168

2. Slide the muffler assembly forward and clear of the holder pins. Account for the gasket.

INSPECTING

1. Inspect the muffler externally for cracks, holes, and dents.
2. Inspect the muffler internally by shaking the muffler back and forth and listening for rattles or loose debris inside the muffler.

■NOTE: For additional details on cleaning the muffler/spark arrester, see Periodic Maintenance/Tune-Up.

INSTALLING

1. With the gasket in place, position the muffler onto the holder pins and slide rearward into position.
2. Secure the muffler to the exhaust pipe with the two exhaust springs.

Cargo Box

REMOVING

1. Disconnect both taillight/brake light connectors. Pull the wiring out of the cargo box frame.



PK157

2. Raise the cargo box; then remove the nuts securing the lower lift supports to the frame. Account for the washers. Do not allow the cargo box to tilt rearward. Tilt the cargo box forward and latch it to the frame.



PK158

3. Remove the retaining clips from each clevis pin; then remove both pivot pins.



PK159

4. Remove the nuts securing the lift supports to the bottom of the cargo box; then remove the lift supports.
5. With the help of an assistant or an adequate lift, release the cargo box latch; then remove the cargo box from the vehicle.

CLEANING AND INSPECTING

1. Clean all cargo box components with soap and water.
2. Inspect the cargo box for cracks, tears, and loose hardware.
3. Inspect the welds of the cargo box frame for cracking or bending.
4. Inspect the cargo box gate latches for smooth operation.

INSTALLING

1. With the help of an assistant or an adequate lift, set the cargo box into position on the frame. Lightly grease the pivot housings; then insert each clevis pin from the inside out. Secure the retaining clips to the end clevis pins.
2. With the cargo box still lowered, connect the lift supports to the bottom of the cargo box. Install each nut and tighten securely.
3. Raise the cargo box. Do not allow it to tilt fully rearward. Align and connect the lift support to the frame; then install the nuts. Tighten securely.
4. Lower the cargo box and lock into position.
5. Route the wiring harness through the bottom corner of the cargo box; then connect the taillight/brake light connectors.

Tailgate

REMOVING

1. Leave the tailgate latched to the cargo bed and remove the cap screws securing the cargo bed cables to the tailgate.



PK323

2. Remove both left and right side rear reflector panels by removing the two cap screws securing each to the tailgate assembly.



PK324

3. Remove the two cap screws securing both left and right pivot panels to the tailgate. Unlatch the tailgate from the cargo bed; then with the aid of an assistant, tilt the tailgate down and lift up to remove.

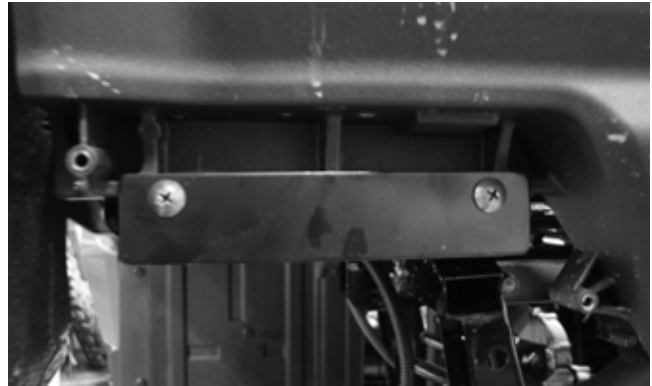

PK325



PK324

3. Using the shoulder head cap screws, secure the cargo bed cables to the tailgate.

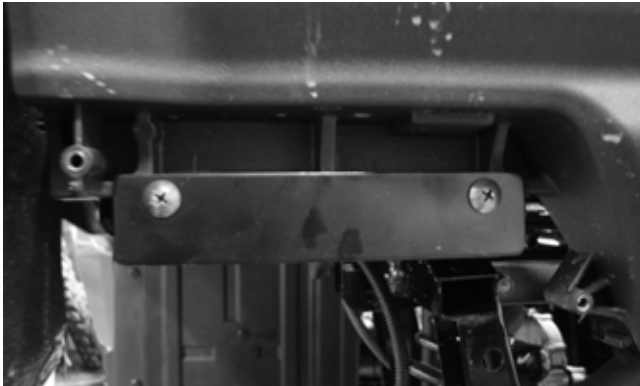

PK325

INSTALLING

1. Place the tailgate into position; then tilt up and latch to the cargo bed.

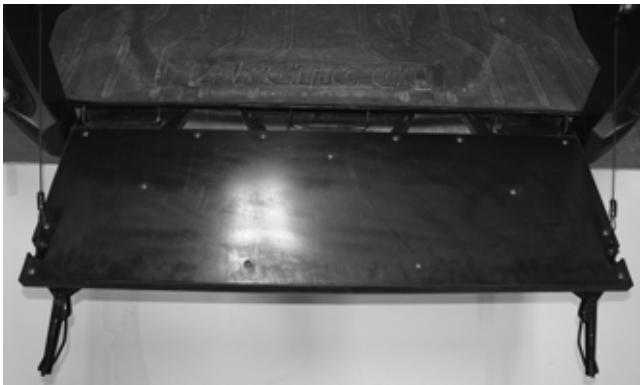

PK326

2. Secure each pivot panel using the two cap screws. Install each rear reflector panel using the two cap screws.

Taillight Assembly

REMOVING

1. Remove the cap screws and lock nuts securing the taillight assembly to the ROPS tube.
2. Remove the two nuts and cap screws securing the steel tie-down to the cargo box.



PK023

3. Remove the six plastic screws securing the rear fender to the cargo box. Remove the rear fender.

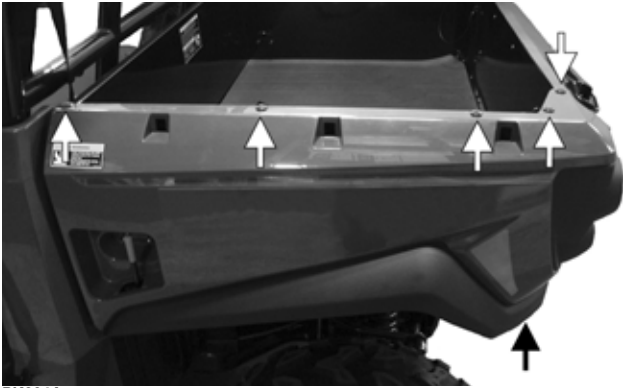

PK064A

4. Remove the taillight/brake light socket by rotating the socket counterclockwise. Rotate the bulb counterclockwise to remove from socket.

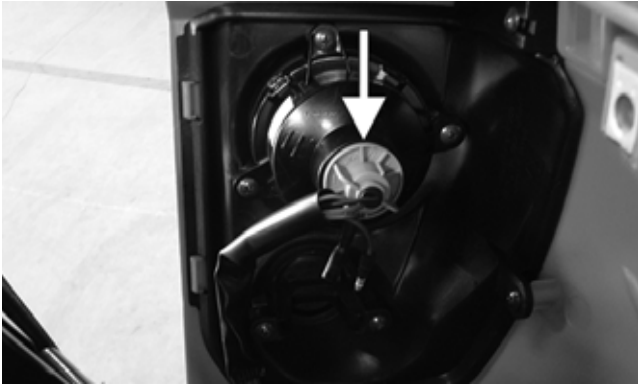

PK328

INSPECTING

1. Inspect wiring harness, three-prong connector, lens, base, cap screws, and socket for damage.
2. Inspect all wires for corroding, pinching, and cracking.
3. Inspect the bulb for wattage, voltage, and proper operation.

INSTALLING

1. Place the rear fender onto the cargo box and secure with the six plastic screws. Secure the tie-down with the two nuts and cap screws.
2. Connect the taillight/brake light connector.

Seat

REMOVING/INSTALLING

1. To remove the seat, raise the front of the seat and slide it forward.
2. To install the seat, slide the rear of the seat into the seat retainers and push down firmly on the front of seat.

Troubleshooting

Problem: Handling too heavy or stiff	
Condition	Remedy
<ol style="list-style-type: none"> 1. Front wheel alignment incorrect 2. Steering shaft binding 3. Tire inflation pressure incorrect 4. Tie rod ends seizing 	<ol style="list-style-type: none"> 1. Adjust alignment 2. Lubricate/replace steering shaft 3. Adjust pressure 4. Replace tie rod ends
Problem: Steering oscillation	
Condition	Remedy
<ol style="list-style-type: none"> 1. Tires inflated unequally 2. Wheel(s) bent 3. Wheel hub studs loose — missing 4. Wheel hub bearing worn — damaged 5. Tie rod ends worn — loose 6. Tires defective — incorrect 7. A-arm bushings damaged 8. Bolts — nuts (frame) loose 	<ol style="list-style-type: none"> 1. Adjust pressure 2. Replace wheel(s) 3. Tighten — replace wheel studs 4. Replace bearing 5. Replace — tighten tie rod ends 6. Replace tires 7. Replace bushings 8. Tighten bolts — nuts
Problem: Steering pulling to one side	
Condition	Remedy
<ol style="list-style-type: none"> 1. Tires inflated unequally 2. Front wheel alignment incorrect 3. Wheel hub bearings worn — broken 4. Frame distorted 5. Shock absorber defective 	<ol style="list-style-type: none"> 1. Adjust pressure 2. Adjust alignment 3. Replace bearings 4. Repair — replace frame 5. Replace shock absorber
Problem: Steering impaired	
Condition	Remedy
<ol style="list-style-type: none"> 1. Tire pressure too high 2. Steering linkage worn 3. Cap screws (suspension system) loose 	<ol style="list-style-type: none"> 1. Adjust pressure 2. Replace linkage 3. Tighten cap screws
Problem: Tire wear rapid or uneven	
Condition	Remedy
<ol style="list-style-type: none"> 1. Wheel hub bearings worn — loose 2. Front wheel alignment incorrect 	<ol style="list-style-type: none"> 1. Replace bearings 2. Adjust alignment
Problem: Steering noise	
Condition	Remedy
<ol style="list-style-type: none"> 1. Caps screws — nuts loose 2. Wheel hub bearings broken — damaged 3. Lubrication inadequate 	<ol style="list-style-type: none"> 1. Tighten cap screws — nuts 2. Replace bearings 3. Lubricate appropriate components
Problem: Rear wheel oscillation	
Condition	Remedy
<ol style="list-style-type: none"> 1. Rear wheel hub bearings worn — loose 2. Tires defective — incorrect 3. Wheel rim distorted 4. Wheel hub cap screws loose 5. Rear suspension arm-related bushing worn 6. Rear shock absorber damaged 7. Rear suspension arm nut loose 	<ol style="list-style-type: none"> 1. Replace bearings 2. Replace tires 3. Replace rim 4. Tighten cap screws 5. Replace bushing 6. Replace shock absorber 7. Tighten nut

Engine/Transmission

This section has been organized into sub-sections which show a progression for the complete servicing of this ROV engine/transmission.

■NOTE: Photos are used for clarification purposes only and may not depict exact situation.

To service the center crankcase halves, the engine/transmission must be removed from the frame. To service top-side, left-side, and right-side components, the engine/transmission does not have to be removed from the frame.

■NOTE: The manufacturer recommends the use of new gaskets, lock nuts, and seals and lubricating all internal components when servicing the engine/transmission.

■NOTE: A new ROV and an overhauled ROV engine require a “break-in” period. The first 10 hours (or 200 miles/320 km) are most critical to the life of this ROV. Proper operation during this break-in period will help ensure maximum life and performance from the ROV. Instruct the customer to follow the proper break-in procedure as described in the Operator’s Manual.

SPECIAL TOOLS

A number of special tools must be available to the technician when performing service procedures in this section. Refer to the current Special Tools Catalog for the appropriate tool description.

■NOTE: When indicated for use, each special tool will be identified by its specific name, as shown in the chart below, and capitalized.

Description	p/n
Seal Protector Tool	Common Tool
Crankcase Separator/Crankshaft Remover	Common Tool
Magneto Rotor Remover Set	0444-254
Piston Pin Puller	Common Tool
Secondary Drive Gear Holder	0444-253
Spanner Wrench	0444-240
Surface Plate	Common Tool
V Blocks	Common Tool

■NOTE: Special tools are available from the Service Department.

Troubleshooting

Problem: Engine will not start or is hard to start (Compression too low)	
Condition	Remedy
<ol style="list-style-type: none"> 1. Valve clearance out of adjustment 2. Valve guides worn 3. Valves mistimed 4. Piston rings worn — broken 5. Cylinder bore worn 6. Starter motor cranks too slowly — does not turn 	<ol style="list-style-type: none"> 1. Adjust clearance 2. Replace guides 3. Retime engine 4. Replace rings 5. Replace cylinder 6. See Electrical System
Problem: Engine will not start or is hard to start (No spark)	
Condition	Remedy
<ol style="list-style-type: none"> 1. Spark plug fouled 2. Spark plug wet 3. Magneto defective 4. ECM defective 5. Ignition coil defective 6. High-tension lead open — shorted 	<ol style="list-style-type: none"> 1. Clean — replace plug 2. Clean — dry plug 3. Replace stator coil 4. Replace ECM 5. Replace ignition coil 6. Replace high tension lead
Problem: Engine will not start or is hard to start (No fuel reaching the fuel injector)	
Condition	Remedy
<ol style="list-style-type: none"> 1. Gas tank vent hose obstructed 2. Fuel hose obstructed 3. Fuel screens obstructed 4. Fuel pump defective 	<ol style="list-style-type: none"> 1. Clean vent hose 2. Clean — replace hose 3. Clean — replace inlet screen 4. Replace fuel pump
Problem: Engine stalls easily	
Condition	Remedy
<ol style="list-style-type: none"> 1. Spark plug fouled 2. Magneto defective 3. ECM defective 4. Fuel injector obstructed 5. Valve clearance out of adjustment 	<ol style="list-style-type: none"> 1. Clean — replace plug 2. Replace stator coil 3. Replace ECM 4. Replace fuel injector 5. Adjust clearance
Problem: Engine noisy (Excessive valve chatter)	
Condition	Remedy
<ol style="list-style-type: none"> 1. Valve clearance excessive 2. Valve spring(s) weak — broken 3. Rocker arm — rocker arm shaft worn 4. Camshaft worn 	<ol style="list-style-type: none"> 1. Adjust clearance 2. Replace spring(s) 3. Replace arm — shaft 4. Replace camshaft
Problem: Engine noisy (Noise seems to come from piston)	
Condition	Remedy
<ol style="list-style-type: none"> 1. Piston — cylinder worn 2. Combustion chamber carbon buildup 3. Piston pin — piston pin bore worn 4. Piston rings — ring groove(s) worn 	<ol style="list-style-type: none"> 1. Replace cylinder — service piston 2. Clean cylinder head and piston 3. Replace — service pin — bore 4. Replace rings — piston
Problem: Engine noisy (Noise seems to come from timing chain)	
Condition	Remedy
<ol style="list-style-type: none"> 1. Chain stretched 2. Sprockets worn 3. Tension adjuster malfunctioning 	<ol style="list-style-type: none"> 1. Replace chain 2. Replace sprockets 3. Repair — replace adjuster
Problem: Engine noisy (Noise seems to come from crankshaft)	
Condition	Remedy
<ol style="list-style-type: none"> 1. Main bearing worn — burned 2. Lower rod-end bearing worn — burned 3. Connecting rod side clearance too large 4. Centrifugal clutch loose 5. Rotor/flywheel loose 	<ol style="list-style-type: none"> 1. Replace bearing 2. Replace crankshaft assembly 3. Replace crankshaft assembly 4. Tighten — replace clutch 5. Tighten — replace flywheel — crankshaft
Problem: Engine noisy (Noise seems to come from transmission)	
Condition	Remedy
<ol style="list-style-type: none"> 1. Gears worn — chipped 2. Splines worn 3. Primary gears worn — chipped 4. Bearings worn 5. Bushing worn 	<ol style="list-style-type: none"> 1. Replace gears 2. Replace shaft(s) — gears 3. Replace gears 4. Replace bearings 5. Replace bushing

Problem: Engine noisy (Noise seems to come from secondary bevel gear and final driven shaft)	
Condition	Remedy
<ol style="list-style-type: none"> 1. Drive — driven bevel gears damaged — worn 2. Backlash excessive 3. Tooth contact improper 4. Bearing damaged 5. Gears worn — chipped 6. Splines worn 7. Final driven shaft thrust clearance too large 	<ol style="list-style-type: none"> 1. Replace gears 2. Adjust backlash 3. Adjust contact 4. Replace bearing 5. Replace gears 6. Replace shaft(s) — gears 7. Replace thrust washer(s)
Problem: Engine idles poorly	
Condition	Remedy
<ol style="list-style-type: none"> 1. Valve clearance out of adjustment 2. Valve seating poor 3. Valve guides defective 4. Rocker arms — arm shaft worn 5. Magneto defective 6. ECM defective 7. Spark plug fouled — gap too wide 8. Ignition coil defective 9. Fuel injector obstructed 	<ol style="list-style-type: none"> 1. Adjust clearance 2. Replace — service seats — valves 3. Replace guides 4. Replace arms — shafts 5. Replace stator coil 6. Replace ECM 7. Adjust gap — replace plug 8. Replace ignition coil 9. Replace fuel injector
Problem: Engine runs poorly at high speed	
Condition	Remedy
<ol style="list-style-type: none"> 1. High RPM “cut out” against RPM limiter 2. Valve springs weak 3. Valve timing out of adjustment 4. Cams — rocker arms worn 5. Spark plug gap too narrow 6. Ignition coil defective 7. Air cleaner element obstructed 8. Fuel hose obstructed 	<ol style="list-style-type: none"> 1. Shift into higher gear — decrease speed 2. Replace springs 3. Adjust timing 4. Replace cams — arms 5. Adjust gap 6. Replace ignition oil 7. Clean element 8. Clean — prime hose
Problem: Exhaust smoke dirty or heavy	
Condition	Remedy
<ol style="list-style-type: none"> 1. Engine oil overfilled — contaminated 2. Piston rings — cylinder worn 3. Valve guides worn 4. Cylinder wall scored — scuffed 5. Valve stems worn 6. Stem seals defective 	<ol style="list-style-type: none"> 1. Drain excess oil — change oil 2. Replace cylinder — service rings 3. Replace guides 4. Replace cylinder 5. Replace valves 6. Replace seals
Problem: Engine lacks power	
Condition	Remedy
<ol style="list-style-type: none"> 1. Valve clearance incorrect 2. Valve springs weak 3. Valve timing out of adjustment 4. Piston ring(s) — cylinder worn 5. Valve seating poor 6. Spark plug fouled 7. Rocker arms — shafts worn 8. Spark plug gap incorrect 9. Fuel injector obstructed 10. Air cleaner element obstructed 11. Engine oil overfilled — contaminated 12. Intake manifold leaking air 13. Cam chain worn 	<ol style="list-style-type: none"> 1. Adjust clearance 2. Replace springs 3. Time camshaft 4. Replace cylinder — service rings 5. Repair seats 6. Clean — replace plug 7. Replace arms — shafts 8. Adjust gap — replace plug 9. Replace fuel injector 10. Clean element 11. Drain excess oil — change oil 12. Tighten — replace manifold 13. Replace cam chain — sprockets
Problem: Engine overheats	
Condition	Remedy
<ol style="list-style-type: none"> 1. Carbon deposit (piston crown) excessive 2. Oil low 3. Octane low — gasoline poor 4. Oil pump defective 5. Oil circuit obstructed 6. Intake manifold leaking air 7. Coolant level low 8. Fan malfunctioning 9. Fan relay malfunctioning 10. Thermostat stuck — closed 11. Radiator hoses — cap damaged — obstructed 	<ol style="list-style-type: none"> 1. Clean piston 2. Add oil 3. Drain — replace gasoline 4. Replace pump 5. Clean circuit 6. Tighten — replace manifold 7. Fill — examine system for leaks 8. Check fan fuse/fan relay — replace fan 9. Replace fan relay 10. Replace thermostat 11. Clear obstruction — replace hoses

Removing Engine/ Transmission

Many service procedures can be performed without removing the engine/transmission from the frame. Closely observe the note introducing each sub-section for this important information.

AT THIS POINT

If the technician's objective is to service/replace right-side cover oil seals, front output joint oil seal, rear output joint oil seal, and/or the oil strainer (from beneath the engine/transmission), the engine/transmission does not have to be removed from the frame.

Support the vehicle on a suitable lift or jack stands allowing room to work.

WARNING

Make sure the vehicle is solidly supported on the support stands to avoid injury.

1. Remove the seat, engine compartment panel, and the battery box cover; then disconnect the negative battery cable and secure it away from the battery. Tilt the cargo bed back.
2. Drain the oil and coolant.
3. Remove both left and right side panel assemblies (see Dashboard).
4. Remove both left and right side rear splash panels.

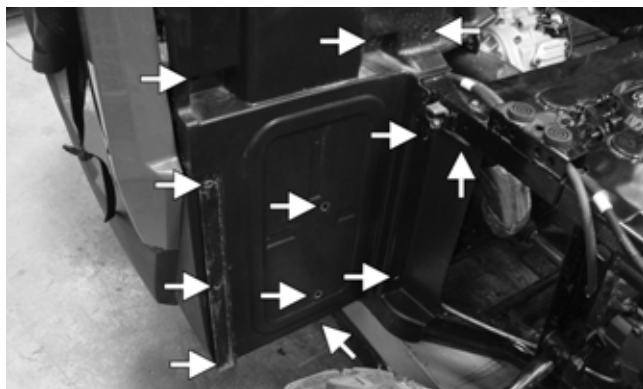

PK108A

5. Loosen the two clamps securing the air inlet and outlet tubes to the air box assembly; then remove the crankcase breather hose from the air box. Remove the two cap screws securing the air box to the seat frame. Remove the air box assembly.

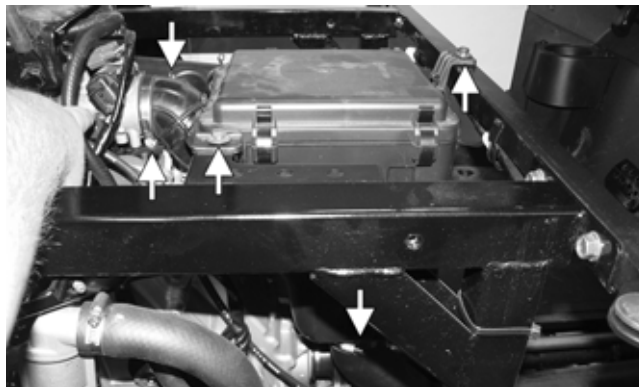

PK160A

6. Remove the harness from the seat frame. Mark the location of the driver's seat belt limiter switch connector; then disconnect the connector.

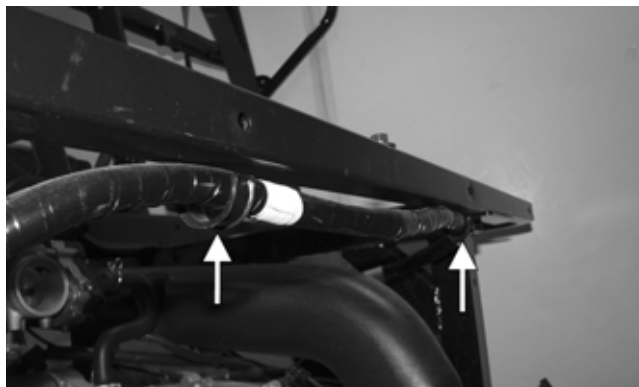

PK161A



PK162

7. Remove the rear gear case bladder from the center splash panel; then remove the cap screw and nut securing the CVT exhaust duct to the seat frame. Loosen the clamp securing the CVT exhaust duct to the front of the CVT housing. Loosen the CVT inlet clamp; then remove the cap screw and lock nut securing the tube to the frame. Remove both ducts.

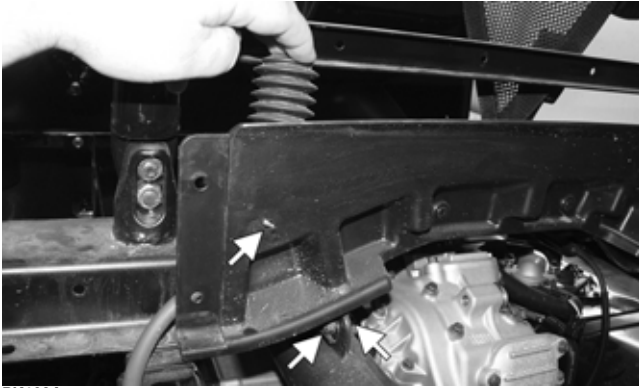

PK163A



PK109A

8. Remove the cap screw securing the thermostat bracket to the seat frame. Pull the gas tank filler neck vent line out from the seat frame.



PK164

9. Loosen the patch-lock cap screws and nuts from each side of the vehicle securing the front and rear ROPS together.



PK089

10. Loosen the cap screws securing the front of the seat frame to the main frame.

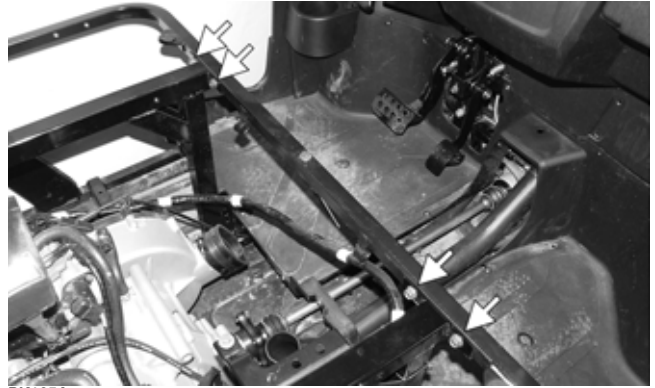

PK165A

11. From each side of the vehicle, loosen the eight cap screws securing the outside of the seat frame to the top of the main frame.

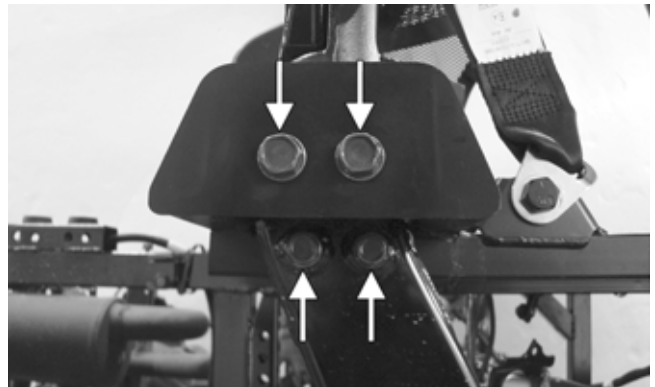

PK166

12. From each side of the vehicle, loosen the cap screws securing the center of the seat frame to the main frame. Once all cap screws are loose, remove all cap screws from steps 10, 11, and 12.

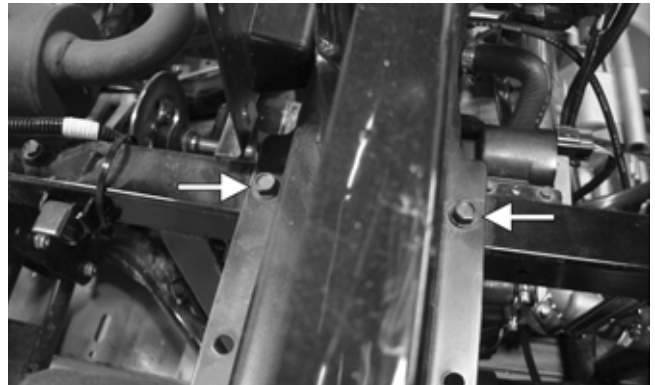

PK167A

13. With the aid of an assistant, remove the cap screws and nuts from step 9 and remove the seat frame and rear ROPS structure as an assembly. Set aside.

14. Remove the two springs securing the muffler to the exhaust pipe; then remove the muffler. Account for an exhaust seal.

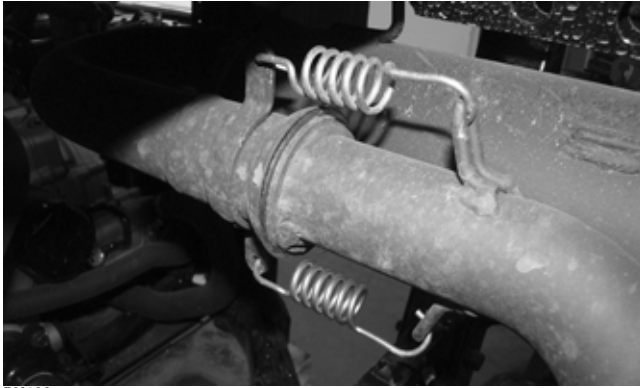

PK168

15. Mark the cable tie location; then remove the cable tie securing the O2 sensor wire to the frame. Disconnect the O2 sensor connector, then remove the two nuts securing the exhaust pipe to the cylinder head. Remove the exhaust pipe. Account for the head pipe gasket.



PK169

16. Remove the spark plug cap from the spark plug. Disconnect the coolant temperature sensor (A), TPS (B), ISC (C), TMAP (D), and fuel injector (E) connectors. Secure the harness out of the way. Loosen the clamp securing the throttle body to the intake boot. Note the throttle cable routing and release the throttle cable from the clamps attached to the top of the CVT housing; then secure the throttle body out of the way.

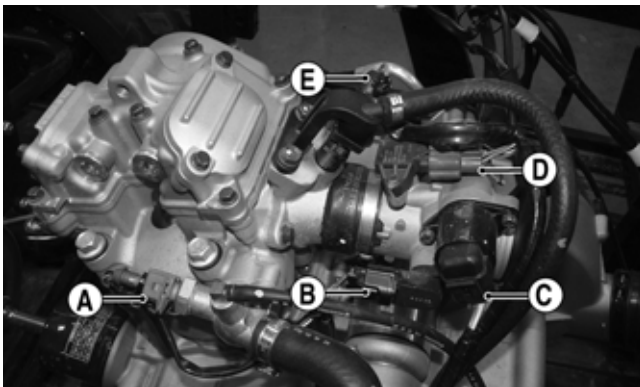

PK170A

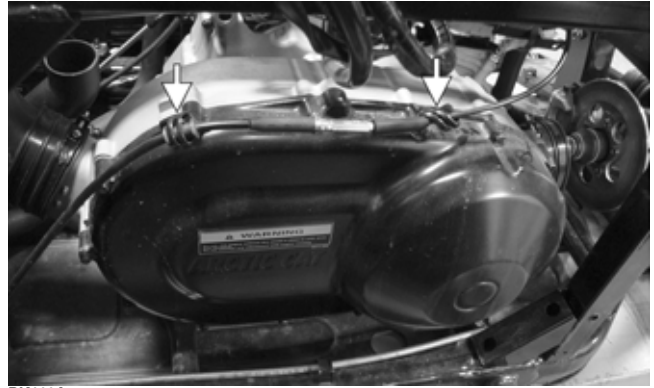

PK111A

17. Remove the starter cable from the starter motor; then remove the engine ground cable from the front starter motor mount.

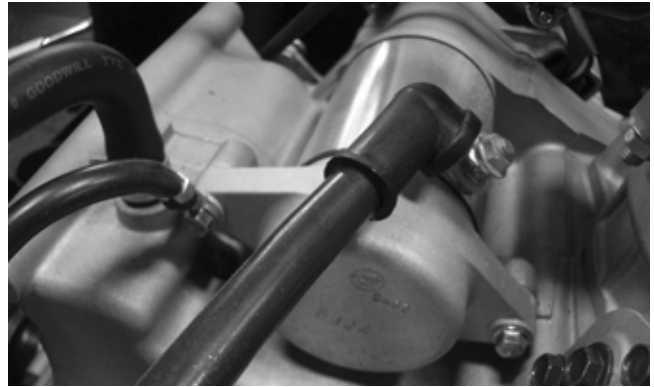

PK171

18. Wrap a shop towel around the fuel injector and rail. Remove the two cap screws securing the fuel rail to the cylinder head. Carefully remove the rail and injector. Account for the O-ring (A) on the injector then release the fuel line from the engine clamp (B). Secure the fuel line out of the way.

⚠ WARNING

Gasoline may be under pressure. Place an absorbant towel around the connector to absorb any gasoline spray when disconnected.



PK172

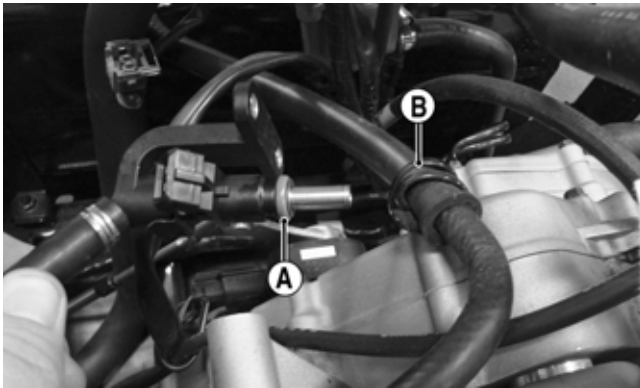

PK173A

19. Remove the cap screw securing the gear shift arm to the shift shaft. Note the alignment punch marks (A) and (B) for assembly purposes. Measure and record the installed threaded set length (E) of the shift cable housing in the shift cable bracket. Loosen the two adjuster nuts; then secure the shift cable out of the way. Disconnect the gear selector switch (C), speed sensor (D), crank position sensor and ACG connectors.

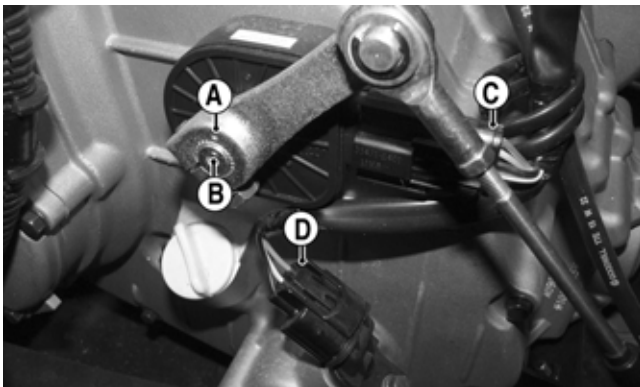

PK174A

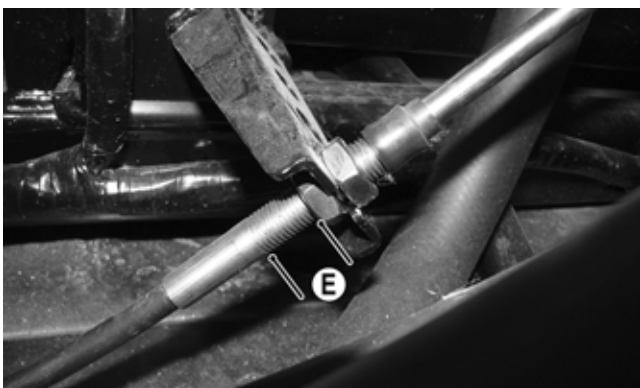

PK102A

20. Remove the large and small diameter coolant outlet hoses from the cylinder head coolant fitting.



PK175

21. Remove both large and small diameter coolant return hoses from the water pump.

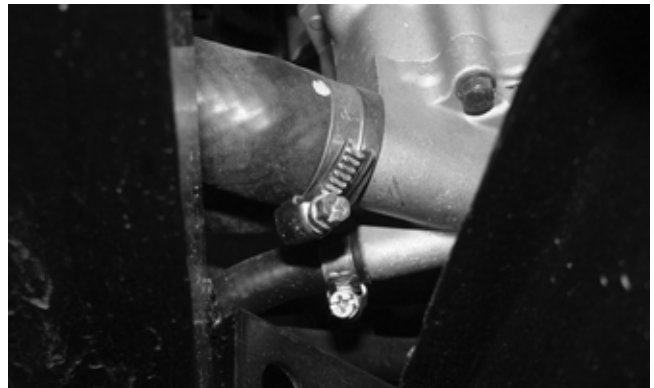

PK176

22. Match mark the flanges; then remove the cap screws securing the front and rear drive shaft flanges to the front and rear engine flanges. Once the cap screws are removed, separate each flange from one another.



PK177

23. Remove the cap screws securing the front engine cradle to the frame; then remove the lock-nuts securing the rear engine cradle to the frame. Discard the lock nuts.

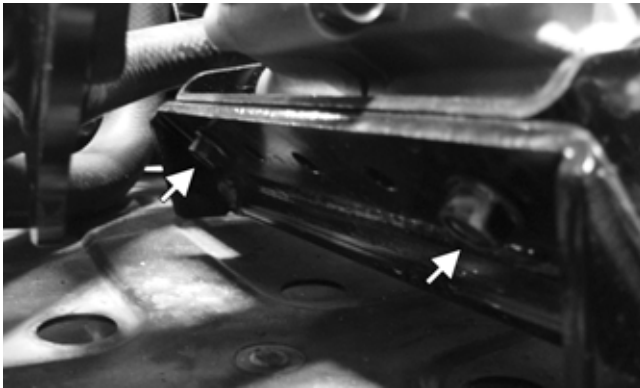

PK178A

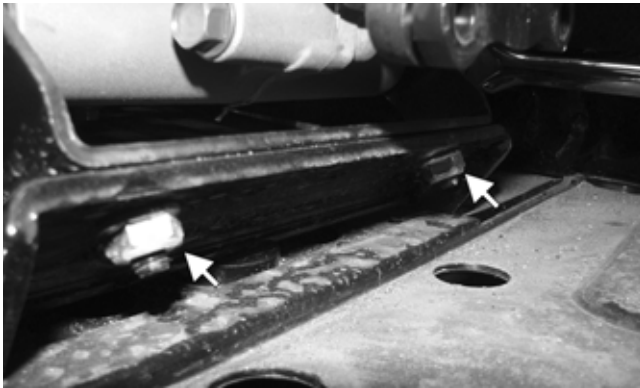

PK179A

24. Attach a suitable lifting sling and, with a suitable engine hoist, slowly lift the engine from the vehicle.
25. Remove the through bolts and lock nuts securing the front and rear engine brackets to the engine. Discard the lock nuts.

Servicing Engine

Top-Side Components	47
Removing Top-Side Components	47
Servicing Top-Side Components	51
Installing Top-Side Components	56
Right-Side Components	60
Removing Right-Side Components	60
Servicing Right-Side Components	62
Installing Right-Side Components	64
Left-Side Components	66
Removing Left-Side Components	66
Servicing Left-Side Components	70
Installing Left-Side Components	72
Center Crankcase Components	76
Separating Crankcase Halves	76
Disassembling Crankcase Half	77
Servicing Center Crankcase Components	79
Assembling Crankcase Half	83
Joining Crankcase Halves	86

Top-Side Components

■NOTE: For efficiency, it is preferable to remove and disassemble only those components which need to be addressed and to service only those components. The technician should use discretion and sound judgment.

AT THIS POINT

To service any one specific component, only limited disassembly of components may be necessary. Note the AT THIS POINT information in each sub-section.

■NOTE: The engine/transmission does not need to be removed from the frame for this procedure.

Removing Top-Side Components

A. Cylinder Head Cover/ Rocker Arms

B. Cylinder Head/Camshaft

■NOTE: Remove the spark plug, timing inspection plug (A), and outer magneto cover plug; then using an appropriate socket and ratchet, rotate the crankshaft counterclockwise to top-dead-center of the compression stroke. Align the "T" mark on the rotor to the timing mark on the magneto cover.

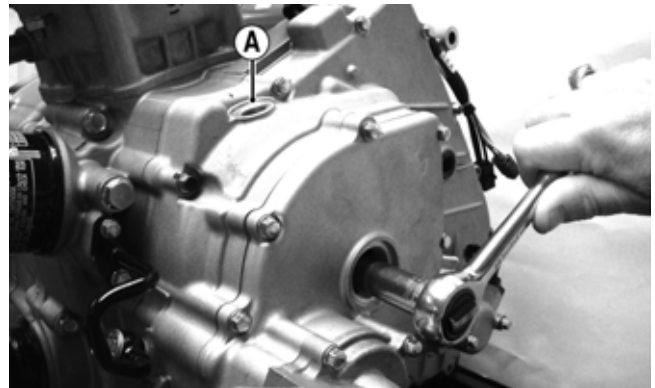

FI605B

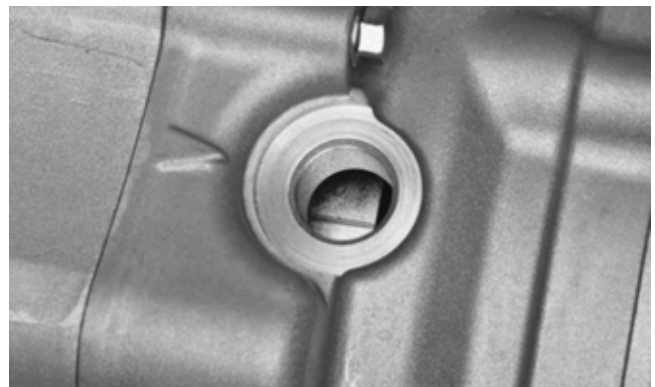

FI709

■NOTE: The manufacturer recommends the use of new gaskets, lock nuts, and seals, and lubricating all internal components when servicing the engine/transmission.

1. Remove the cap screws securing the two tappet covers. Remove the two tappet covers. Account for the O-rings.

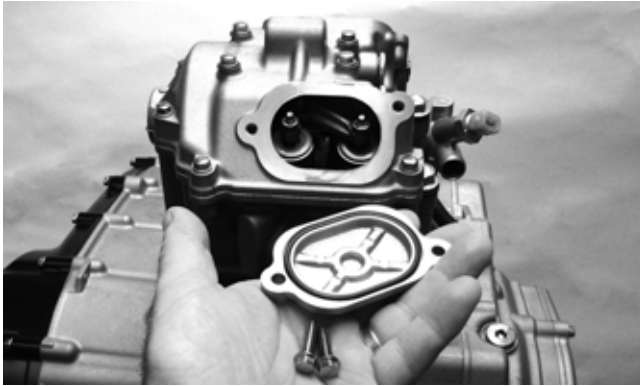

FI603

■NOTE: Keep the mounting hardware with the covers for assembly purposes.

2. Remove the cylinder head cover cap screws. Note the rubber washers on the four top-side cap screws; remove the cylinder head cover. Note the orientation of the cylinder head plug and remove it. Note the location of the two alignment pins.

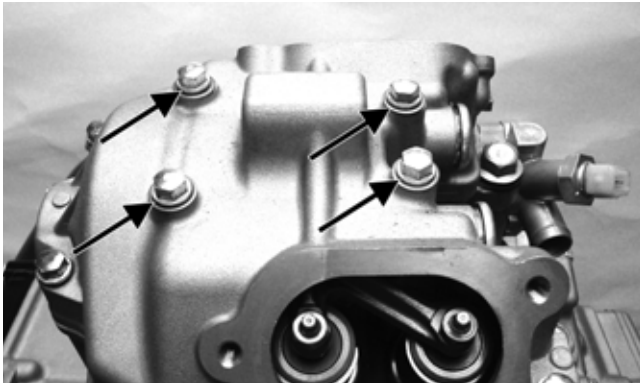

FI606A

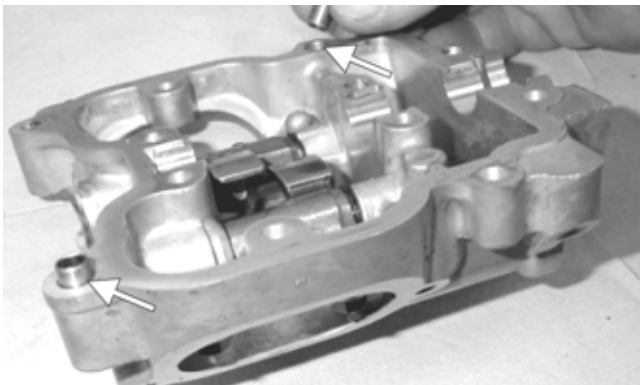

MD1354A

3. Remove the cap screw from the tension adjuster; then using a flat-blade screwdriver, relax the cam chain tension by rotating the adjuster screw clockwise until it locks.

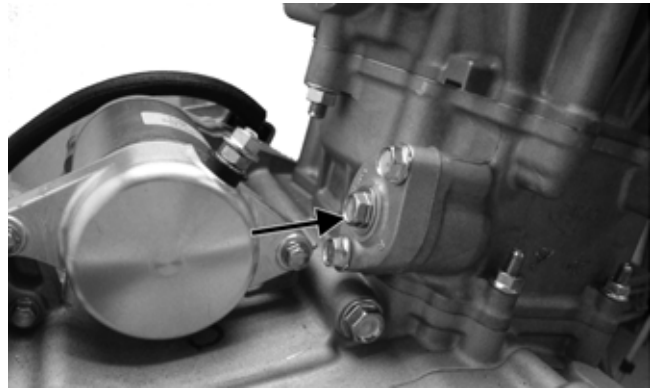

FI607A

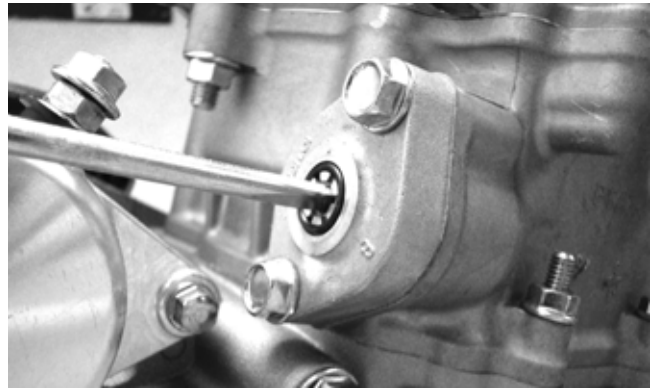

FI608

4. Bend the washer tabs and remove the two cap screws securing the sprocket to the camshaft.



FI612

5. Using an awl, rotate the C-ring in its groove until it is out of the cylinder head; then remove the C-ring.

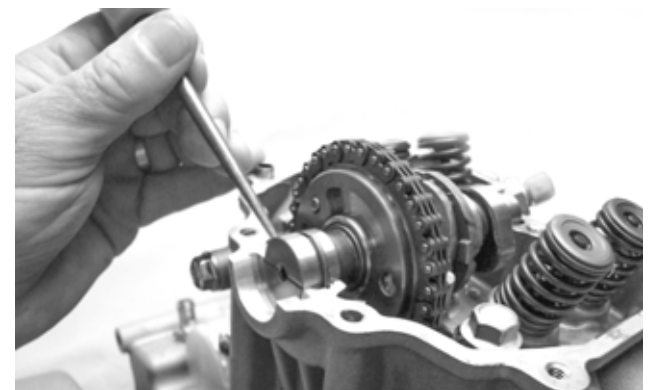

FI613

■NOTE: Care should be taken not to drop the C-ring down into the crankcase.

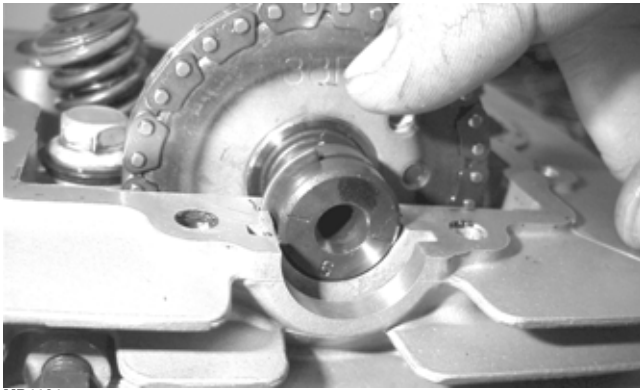

MD1131

6. Noting the timing marks for installing purposes, drop the sprocket off the camshaft. While holding the cam chain, slide the sprocket and camshaft out of the cylinder head. Account for an alignment pin.

■NOTE: Loop the chain over the cylinder and secure it to keep it from falling into the crankcase.

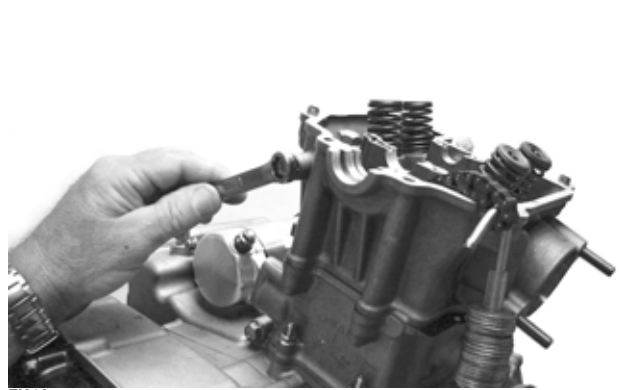

FI616

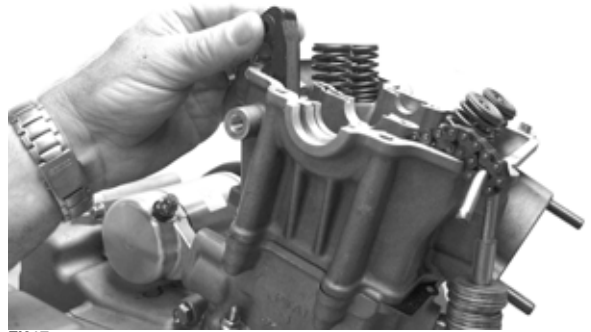

FI617

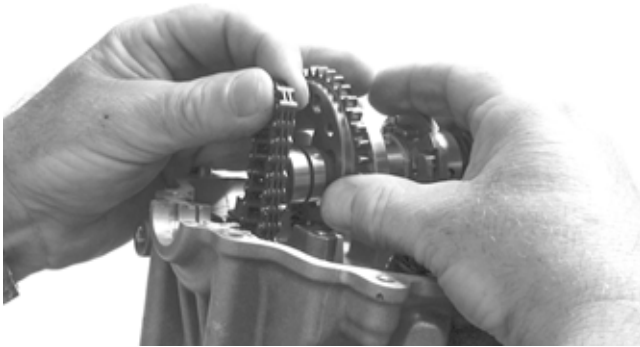

FI620

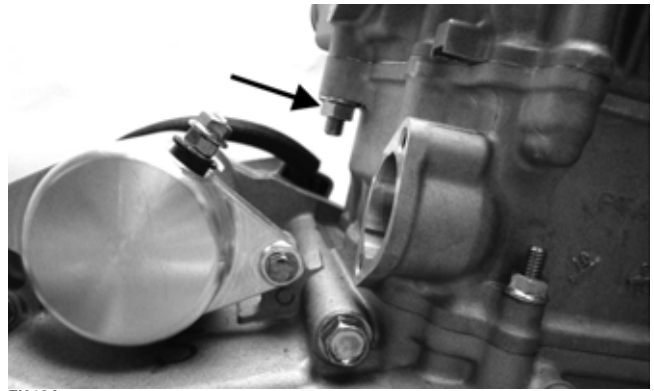

FI618A

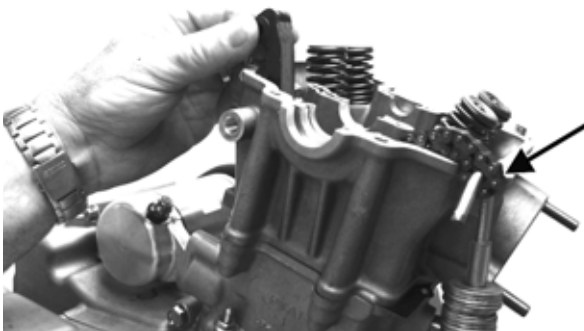

FI617A

7. Remove the cam chain tensioner pivot bolt and remove the chain tensioner; then remove the two nuts securing the cylinder head to the cylinder.

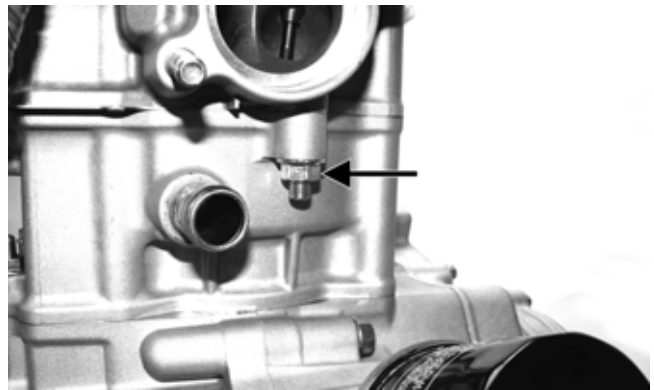

FI619A

8. Remove the four cylinder head cap screws and washers. Note that the two cap screws on the right side of the cylinder head nearest the cam sprocket are longer than the two cap screws on the left (spark plug) side.

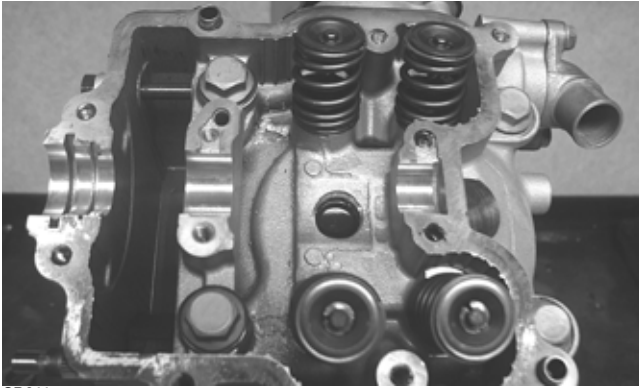

CD211

9. Remove the cylinder head from the cylinder, remove the gasket, and account for two alignment pins.

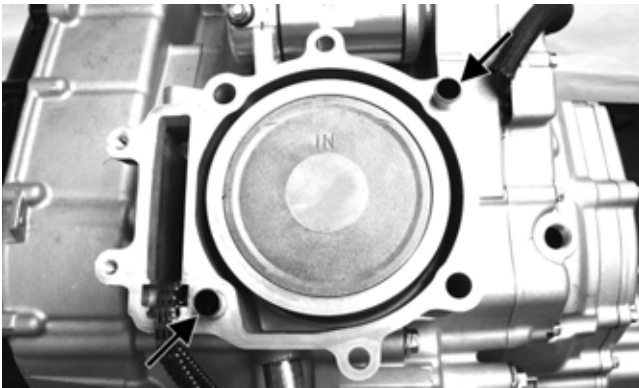

FI623A

AT THIS POINT

To service valves and cylinder head, see Servicing Top-Side Components sub-section.

10. Remove the cam chain guide.

AT THIS POINT

To inspect cam chain guide, see Servicing Top-Side Components sub-section.



FI621

C. Cylinder

D. Piston

■NOTE: Steps 1-10 in the preceding sub-section must precede this procedure.

11. Remove the two nuts securing the right side of the cylinder to the right-side crankcase half.

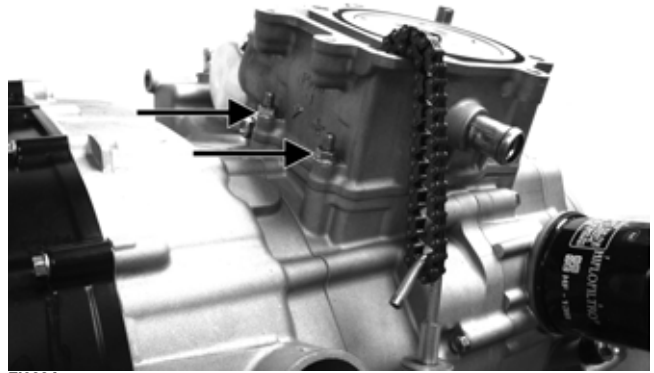

FI622A

12. Lift the cylinder off the crankcase taking care not to allow the piston to drop against the crankcase. Account for the gasket and two alignment pins.

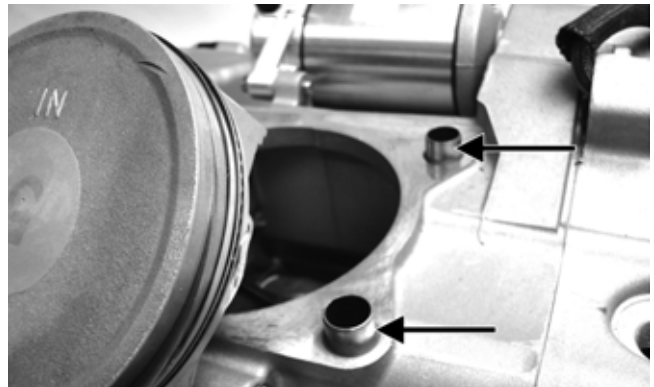

FI624A

AT THIS POINT

To service cylinder, see Servicing Top-Side Components sub-section.

CAUTION

When removing the cylinder, be sure to support the piston to prevent damage to the crankcase and piston.

13. Using an awl, remove one piston-pin circlip. Take care not to drop it into the crankcase.



FI625

14. Using Piston Pin Puller, remove the piston pin. Account for the opposite-side circlip. Remove the piston.

■NOTE: It is advisable to remove the opposite-side circlip prior to using the puller.

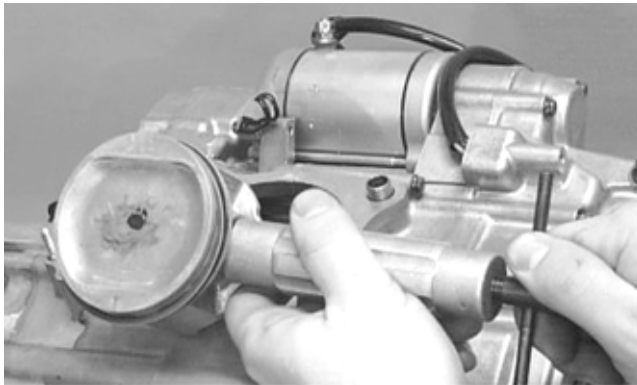

MD1219

■NOTE: Support the connecting rod with rubber bands to avoid damaging the rod or install a connecting rod holder.

CAUTION

Do not allow the connecting rod to go down inside the crankcase. If the rod is down inside the crankcase and the crankshaft is rotated, severe damage will result.

AT THIS POINT

To service piston, see Servicing Top-Side Components sub-section.

AT THIS POINT

To service center crankcase components only, proceed to Removing Right-Side Components.

Servicing Top-Side Components

VALVE ASSEMBLY

When servicing valve assembly, inspect valve seats, valve stems, valve faces, and valve stem ends for pits, burn marks, or other signs of abnormal wear.

■NOTE: Whenever a valve is out of tolerance, it must be replaced.

Cleaning/Inspecting Cylinder Head Cover

■NOTE: If the cylinder head cover cannot be trued, the cylinder head assembly must be replaced.

1. Wash the cylinder head cover in parts-cleaning solvent.

2. Place the cylinder head cover on the Surface Plate covered with #400 grit wet-or-dry sandpaper. Using light pressure, move the cylinder head cover in a figure-eight motion. Inspect the sealing surface for any indication of high spots. A high spot can be noted by a bright metallic finish. Correct any high spots before assembly by continuing to move the cylinder head cover in a figure-eight motion until a uniform bright metallic finish is attained.

CAUTION

Do not remove an excessive amount of the sealing surface or damage to the camshaft will result. Always check camshaft clearance when resurfacing the cylinder head cover.

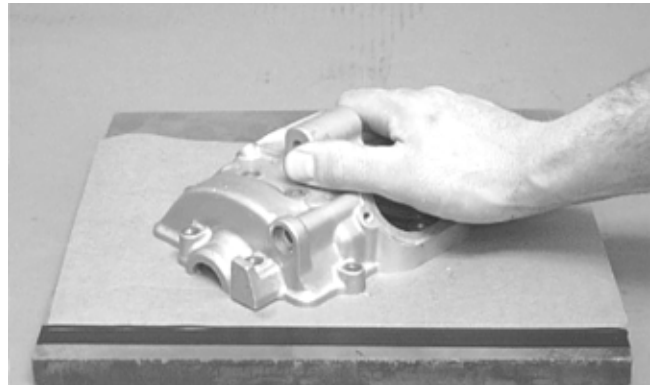

CC130D

CAUTION

Water or parts-cleaning solvent must be used in conjunction with the wet-or-dry sandpaper or damage to the sealing surface may result.

Removing Valves

■NOTE: Index all valves, springs, and cotters to their original position when removing. When installing, all valve components should be installed in their original position.

1. Using a valve spring compressor, compress the valve springs and remove the valve keepers. Account for an upper spring retainer.

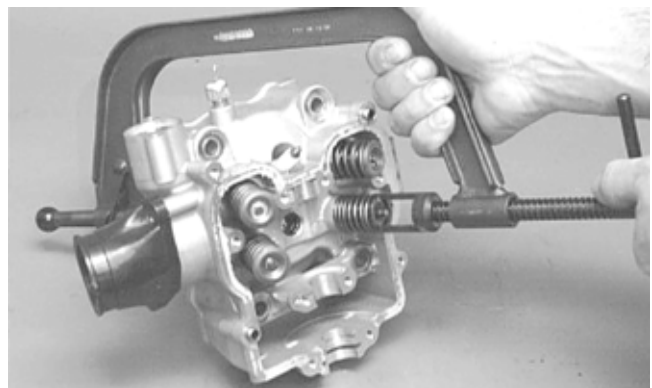

CC132D

2. Remove the valve seal and the lower remaining spring seat. Discard the valve seal.

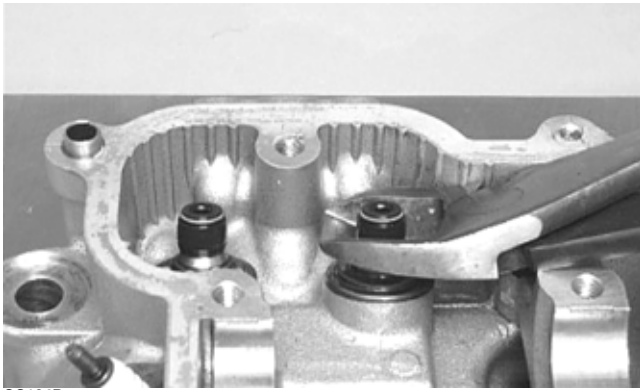

CC134D

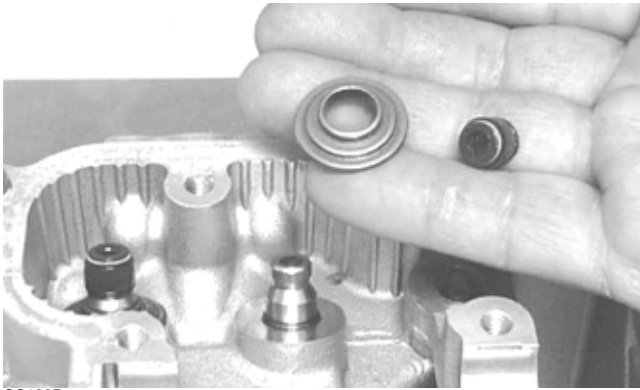

CC136D

■NOTE: The valve seals must be replaced.

3. Remove the valve springs; then invert the cylinder head and remove the valves.

Measuring Valve Guide (Bore)

1. Insert a snap gauge 1/2 way down into each valve guide bore; then remove the gauge and measure it with a micrometer.
2. Acceptable inside diameter range must be within specifications.
3. If a valve guide is out of tolerance, the cylinder head must be replaced.

Servicing Valves/Valve Guides/Valve Seats

If valves, valve guides, or valve seats require servicing or replacement, the manufacturer recommends that the components be taken to a qualified machine shop for servicing.

CAUTION

If valves are discolored or pitted or if the seating surface is worn, the valve must be replaced. Do not attempt to grind the valves or severe engine damage may occur.

Installing Valves

1. Apply grease to the inside surface of the valve seals; then place a lower spring seat and valve guide seal over each valve guide.

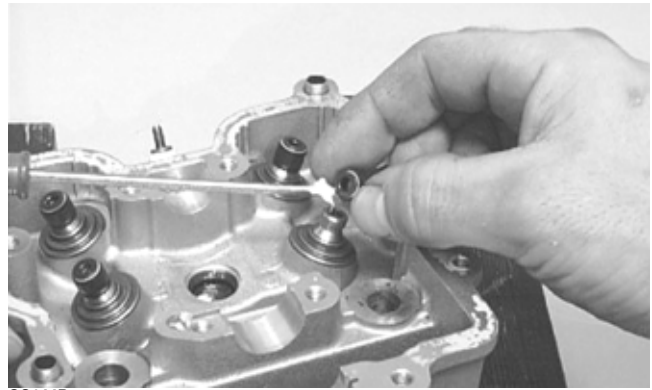

CC144D

2. Insert each valve into its original valve location.
3. Install the valve springs with the painted end of the spring facing away from the cylinder head.

■NOTE: If the paint is not visible, install the ends of the springs with the closest wound coils toward the head.

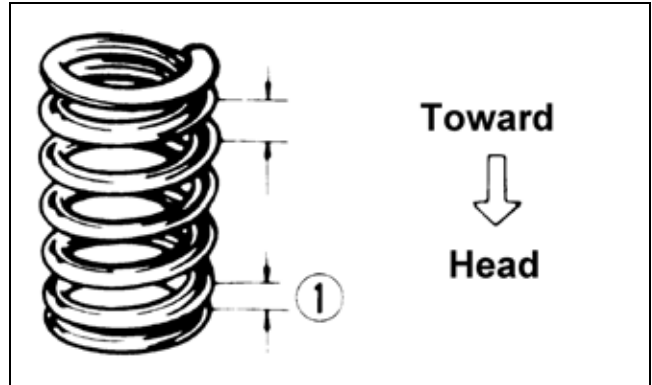

ATV-1011A

4. Place a spring retainer over the valve springs; then using the valve spring compressor, compress the valve springs and install the valve keepers.

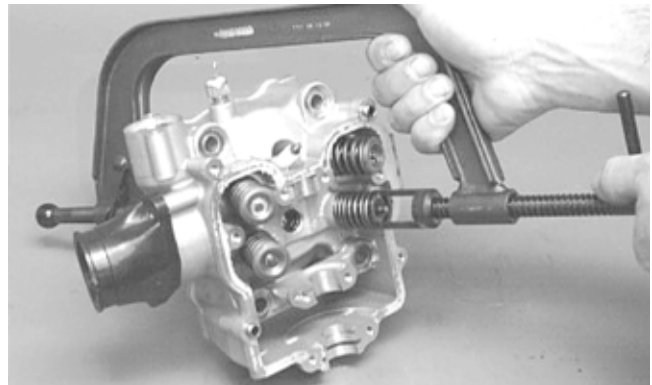

CC132D

PISTON ASSEMBLY

■NOTE: Whenever a piston, rings, or pin are out of tolerance, they must be replaced.

Inspecting Piston

1. Inspect the piston for cracks in the piston pin, boss, top, and skirt areas.
2. Inspect the piston for seizure marks or scuffing. If piston is scored or galled, replace it with a new one.

3. Inspect the perimeter of each piston for signs of “blowby” indicated by dark discoloration. “Blowby” is caused by worn piston rings, excessive carbon in ring grooves, or an out-of-round cylinder.

Removing Piston Rings

1. Starting with the top ring, slide one end of the ring out of the ring-groove.



CC400D

2. Remove each ring by working it toward the top of the piston while rotating it out of the groove.

■NOTE: When installing new rings, install as a complete set only.

Measuring Piston-Ring End Gap (Installed)

1. Place each piston ring in the wear portion of the cylinder. Use the piston to position each ring squarely in the cylinder.
2. Using a feeler gauge, measure each piston-ring end gap. Acceptable ring end gap must not exceed specifications.

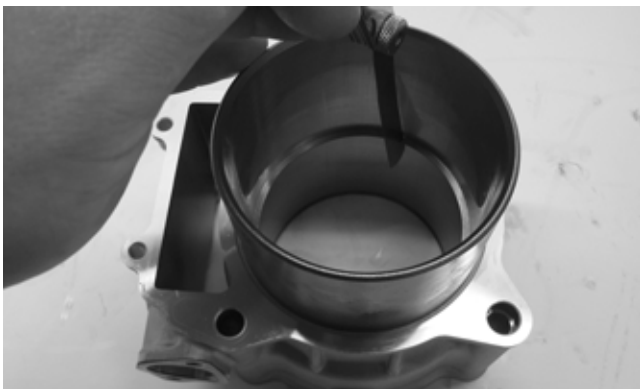

FI711

Measuring Piston Pin, Connecting Rod Small End, and Piston-Pin Bore

1. Measure the piston pin outside diameter at each end and in the center. If measurement does not meet specifications, the piston pin must be replaced.

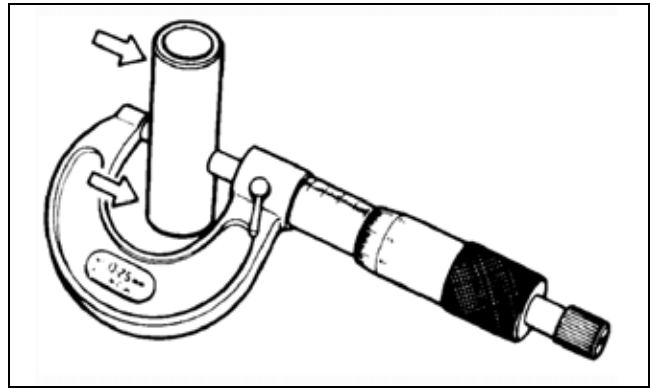

ATV-1070

2. Inspect and measure the connecting rod small end inside diameter. If the measurement exceeds specifications, the connecting rod must be replaced (see Center Crankcase Components in this section).
3. Insert an inside dial indicator into the piston-pin bore. Take two measurements to ensure accuracy. The diameter must not exceed specifications. If the diameter exceeds specifications, the piston must be replaced.

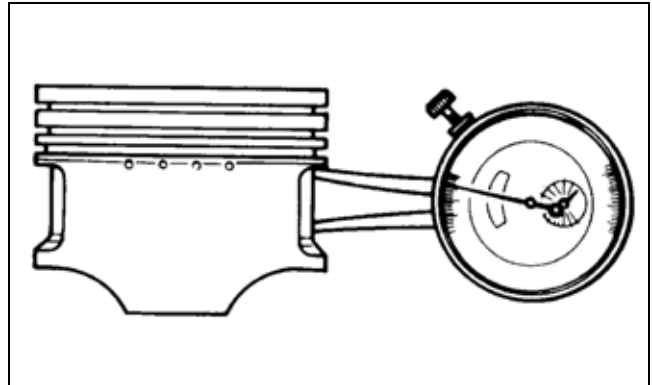

ATV-1069

Measuring Piston Skirt/Cylinder Clearance

1. Measure the cylinder front to back in six places.

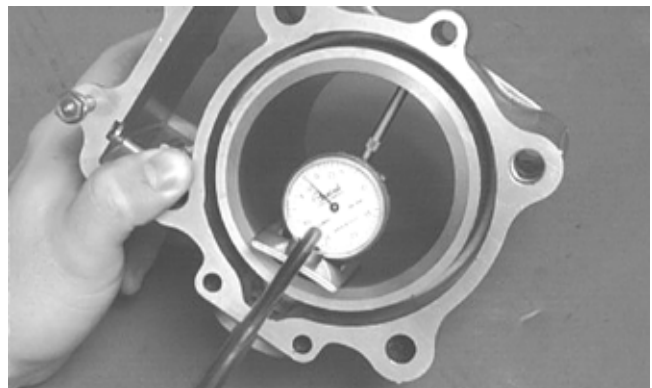

CC127D

2. Measure the corresponding piston diameter at a point 8 mm (0.3 in.) above the piston skirt at a right angle to the piston-pin bore. Subtract this measurement from the larger measurement in step 1. The difference (clearance) must be within specifications.

Installing Piston Rings

1. Install ring expander (4) in the bottom groove of the piston; then install the thin oil rings (3) over the expander making sure the expander ends do not overlap. Stagger the end gaps of the upper and lower thin oil rings according to the illustration.

■NOTE: Note the direction of the exhaust side of the piston (5) for correct ring end gap orientation.

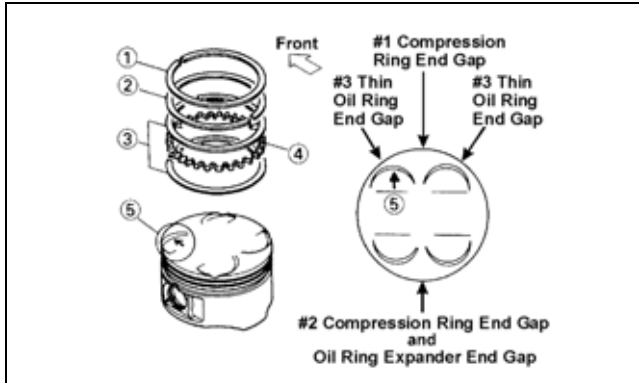

ATV-1085B

2. Install the compression rings (1 and 2) so the letter(s) on the top surface of each ring faces the dome of the piston. Rotate the rings until the ring end gaps are on directly opposite sides of the piston according to the illustration.

■NOTE: The chrome (silver) ring should be installed in the top position.

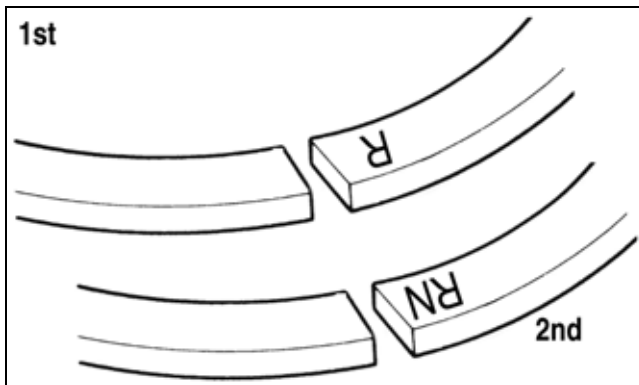

MD1343A

CAUTION

Incorrect installation of the piston rings will result in engine damage.

CYLINDER/CYLINDER HEAD ASSEMBLY

■NOTE: If the cylinder/cylinder head assembly cannot be trued, they must be replaced.

Cleaning/Inspecting Cylinder Head

CAUTION

The cylinder head studs must be removed for this procedure.

1. Using a non-metallic carbon removal tool, remove any carbon buildup from the combustion chamber being careful not to nick, scrape, or damage the combustion chamber or the sealing surface.

2. Inspect the spark plug hole for any damaged threads. Repair damaged threads using a “heli-coil” insert.
3. Place the cylinder head on the surface plate covered with #400 grit wet-or-dry sandpaper. Using light pressure, move the cylinder head in a figure-eight motion. Inspect the sealing surface for any indication of high spots. A high spot can be noted by a bright metallic finish. Correct any high spots before assembly by continuing to move the cylinder head in a figure-eight motion until a uniform bright metallic finish is attained.

CAUTION

Water or parts-cleaning solvent must be used in conjunction with the wet-or-dry sandpaper or damage to the sealing surface may result.

Measuring Cylinder Head Distortion

1. Remove any carbon buildup in the combustion chamber.
2. Lay a straightedge across the cylinder head; then using a feeler gauge, check the distortion factor between the head and the straightedge.
3. Maximum distortion must not exceed specifications.



CC141D

Cleaning/Inspecting Cylinder

1. Wash the cylinder in parts-cleaning solvent.
2. Inspect the cylinder for pitting, scoring, scuffing, warpage, and corrosion. If marks are found, repair the surface using a cylinder hone (see Honing Cylinder in this sub-section).
3. Place the cylinder on the surface plate covered with #400 grit wet-or-dry sandpaper. Using light pressure, move the cylinder in a figure-eight motion. Inspect the sealing surface for any indication of high spots. A high spot can be noted by a bright metallic finish. Correct any high spots before assembly by continuing to move the cylinder in a figure-eight motion until a uniform bright metallic finish is attained.

CAUTION

Water or parts-cleaning solvent must be used in conjunction with the wet-or-dry sandpaper or damage to the sealing surface may result.

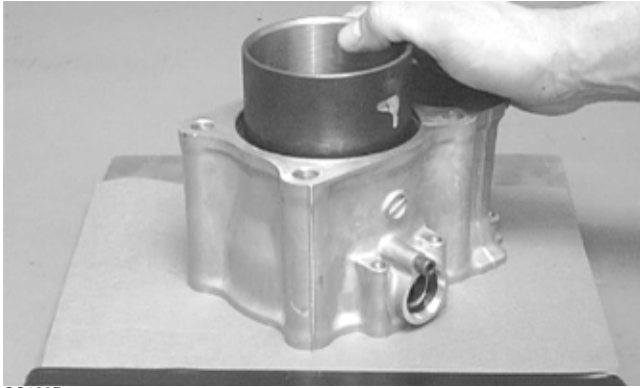

CC129D

Inspecting Cam Chain Guide

1. Inspect cam chain guide for cuts, tears, breaks, or chips.
2. If the chain guide is damaged, it must be replaced.

Honing Cylinder

1. Using a slide gauge and a dial indicator or a snap gauge, measure the cylinder bore diameter in three locations from top to bottom and again from top to bottom at 90° from the first measurements for a total of six measurements. The trueness (out-of-roundness) is the difference between the highest and lowest reading. Maximum trueness (out-of-roundness) must not exceed specifications.

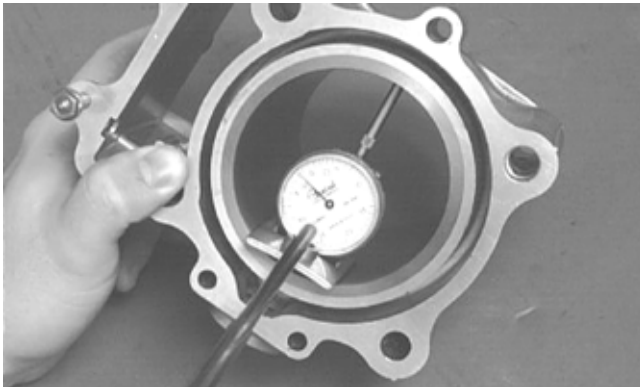

CC127D

2. Wash the cylinder in parts-cleaning solvent.
3. Inspect the cylinder for pitting, scoring, scuffing, and corrosion. If marks are found, repair the surface using a #320 grit ball hone.

■NOTE: To produce the proper 60° crosshatch pattern, use a low RPM drill (600 RPM) at the rate of 30 strokes per minute. If honing oil is not available, use a lightweight petroleum-based oil. Thoroughly clean cylinder after honing using soap and hot water. Dry with compressed air; then immediately apply oil to the cylinder bore. If the bore is severely damaged or gouged, replace the cylinder.

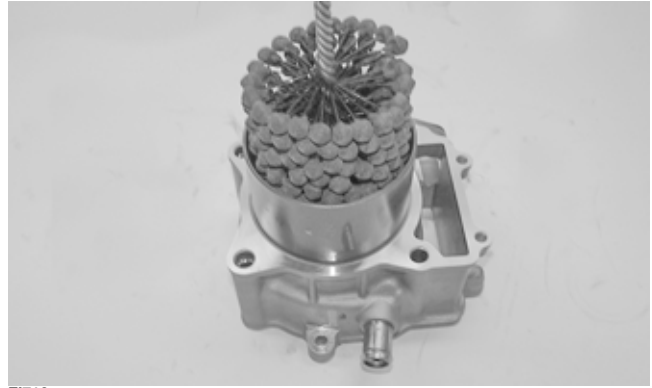

FI712

4. If any measurement exceeds the limit, the cylinder must be replaced.

Measuring Camshaft Runout

■NOTE: If the camshaft is out of tolerance, it must be replaced.

1. Place the camshaft on a set of V blocks; then position the dial indicator contact point against the shaft and zero the indicator.

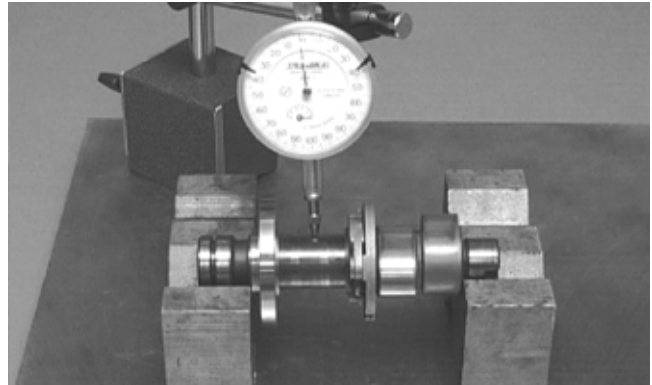

CC283D

2. Rotate the camshaft and note runout; maximum tolerance must not exceed specifications.

Measuring Camshaft Lobe Height

1. Using a calipers, measure each cam lobe height.

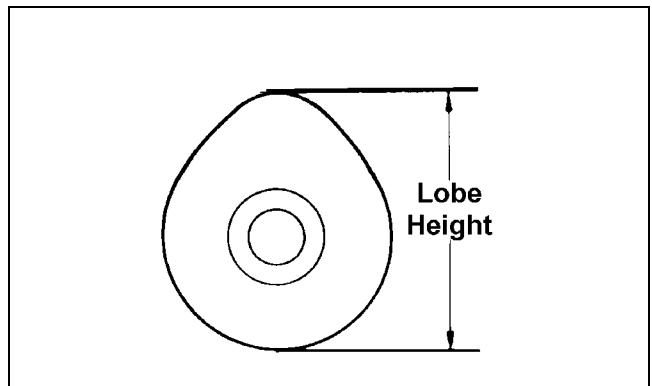

ATV1013A

2. The lobe heights must be greater than minimum specifications.

Inspecting Camshaft Bearing Journal

1. Inspect the bearing journal for scoring, seizure marks, or pitting.

2. If excessive scoring, seizure marks, or pitting is found, the cylinder head assembly must be replaced.

■NOTE: If the journals are worn, replace the camshaft.

Inspecting Camshaft Spring/Drive Pin

1. Inspect the spring and unloader pin for damage.

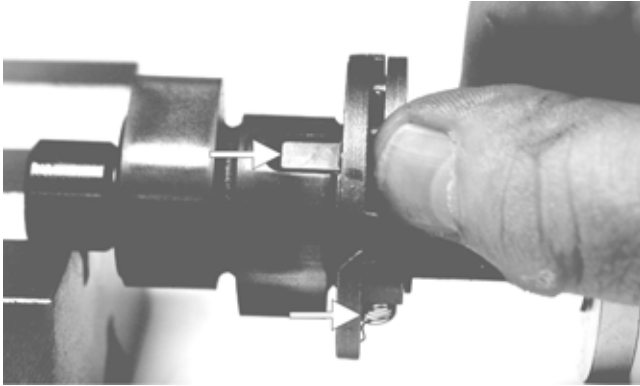

CF061A

■NOTE: With the weight extended, the unloader pin should be flat-side out; with the weight retracted, the unloader pin should be round-side out.

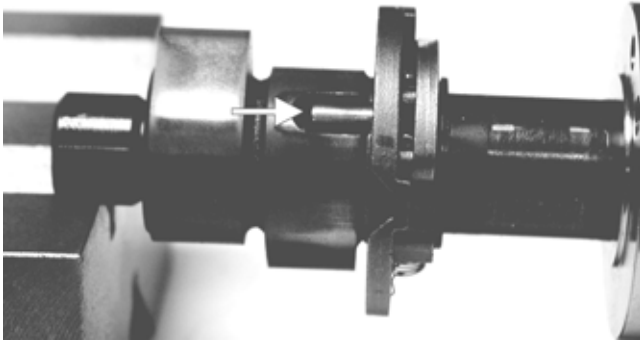

CF060A

2. If damaged, the camshaft must be replaced.

Installing Top-Side Components

A. Piston

B. Cylinder

1. Lubricate the piston pin, connecting rod, and piston pin bore with motor oil; then install the piston on the connecting rod making sure there is a circlip on each side.



FI626

■NOTE: The piston should be installed so the IN points toward the intake side.

2. Place the two alignment pins into position. Place a new cylinder gasket into position; then place a piston holder (or suitable substitute) beneath the piston skirt and square the piston in respect to the crankcase.



FI713

3. Lubricate the inside wall of the cylinder; then using a ring compressor or the fingers, compress the rings and slide the cylinder over the piston. Route the cam chain up through the cylinder cam chain housing; then remove the piston holder and seat the cylinder firmly on the crankcase.

CAUTION

The cylinder should slide on easily. Do not force the cylinder or damage to the piston, rings, cylinder, or crankshaft assembly may occur.

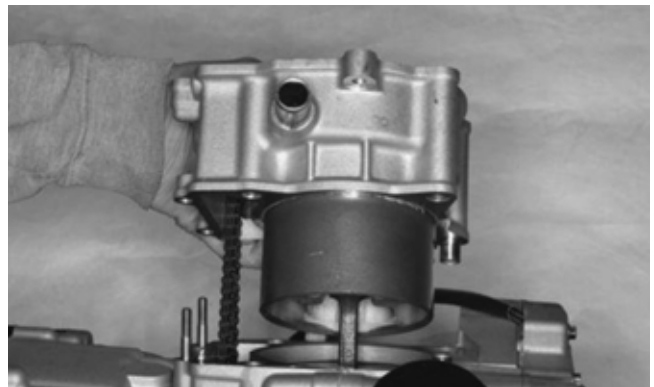

FI710

4. Loosely install the two nuts securing the cylinder to the right-side crankcase half.

■NOTE: The two cylinder-to-crankcase nuts will be tightened in step 9.

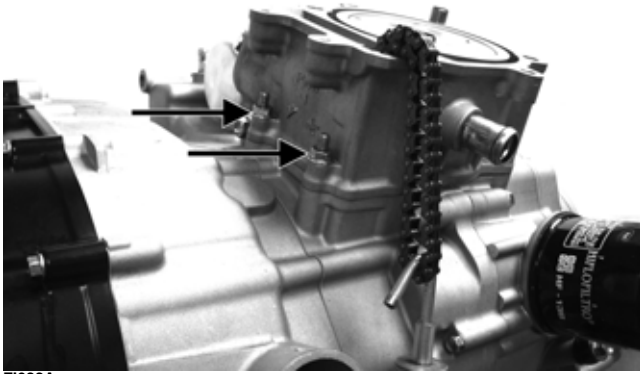

FI622A

C. Cylinder Head/Camshaft
D. Cylinder Head Cover/Rocker Arms

■NOTE: Steps 1-4 in the preceding sub-section must precede this procedure.

5. While keeping tension on the cam chain, place the front cam chain guide into the cylinder.

CAUTION

Care should be taken that the bottom of the chain guide is secured in the crankcase boss.



FI621

6. Place a new gasket into position on the cylinder. Place the alignment pins into position; then place the head assembly into position on the cylinder making sure the cam chain is routed through the chain cavity.

CAUTION

Keep tension on the cam chain to avoid damaging the crankcase boss.

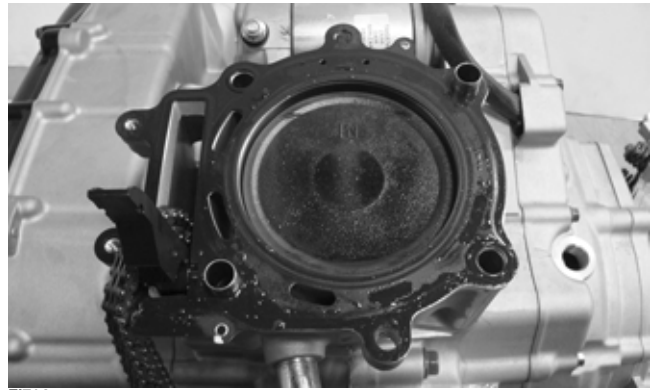

FI714

7. Install the four cylinder head cap screws with washers. Tighten only until snug. Note that the two cap screws on the right side of the cylinder head nearest the cam sprocket are longer than the two cap screws on the left (spark plug) side. Tighten only until snug.

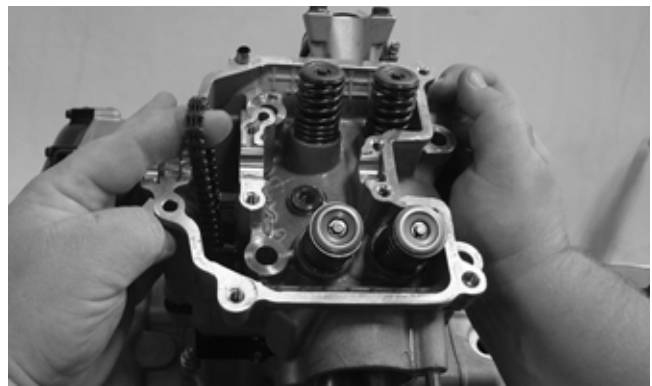

FI715

8. Install the two lower nuts securing the cylinder head to the cylinder, one in front and one in rear.
9. In a crisscross pattern, tighten the four cylinder head cap screws (from step 7) to 28 ft-lb (38.1 N-m). Tighten the two lower cylinder head nuts (from step 8) to 20 ft-lb (27.2 N-m) and the cylinder-to-crankcase nuts (from step 4) to 8 ft-lb (10.9 N-m).
10. With the timing inspection plug removed and the cam chain held tight, rotate the crankshaft until the piston is at top-dead-center.

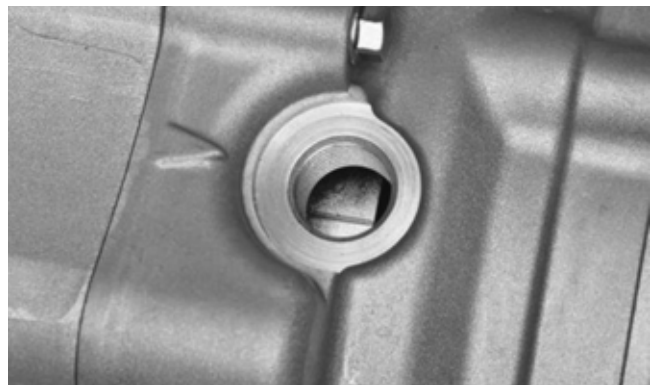

FI709

11. While holding the cam chain to the front, install the rear cam chain tensioner guide into the cylinder head. Install the pivot cap screw and washer. Tighten to 11 ft-lb (15 N-m).

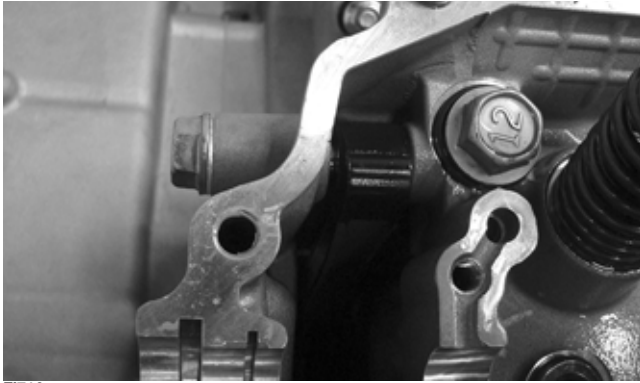

FI716

12. With the alignment pin installed in the camshaft and the cam lobes directed down (toward the piston), place the camshaft in position and verify that the timing mark on the magneto is visible through the inspection plug and that the timing marks on the camshaft sprocket are parallel with the valve cover mating surface.

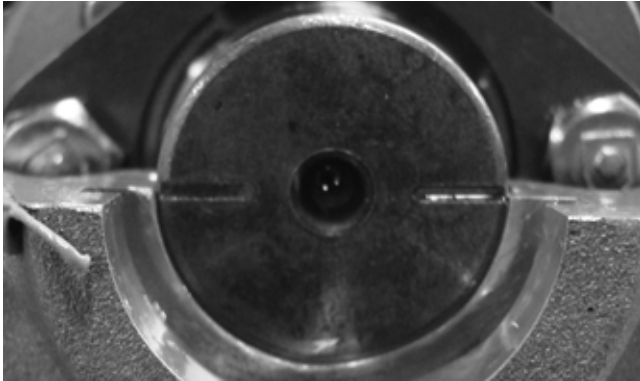

FI717

■NOTE: When the camshaft assembly is seated, make sure the alignment pin in the camshaft aligns with the smallest hole in the sprocket.

13. With the alignment pin installed in the camshaft, loosely place the cam sprocket (with the recessed side facing the camshaft lobes) onto the camshaft and place it into position with the cam chain over the sprocket.

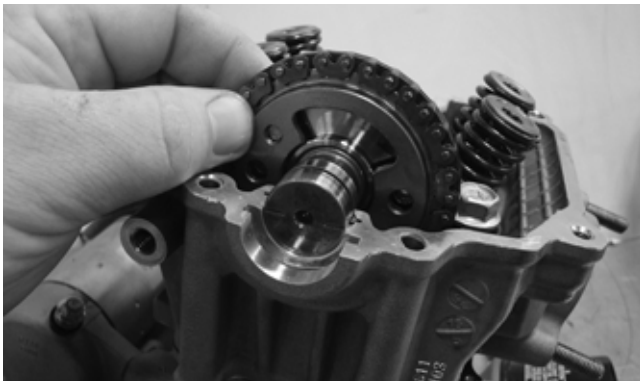

FI718

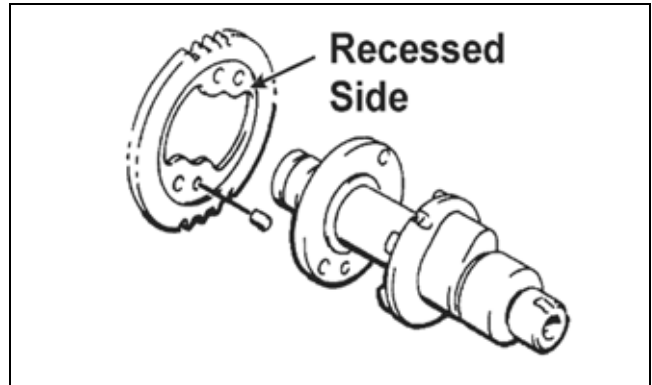

MD1359

14. Place the C-ring into position in its groove in the cylinder head.

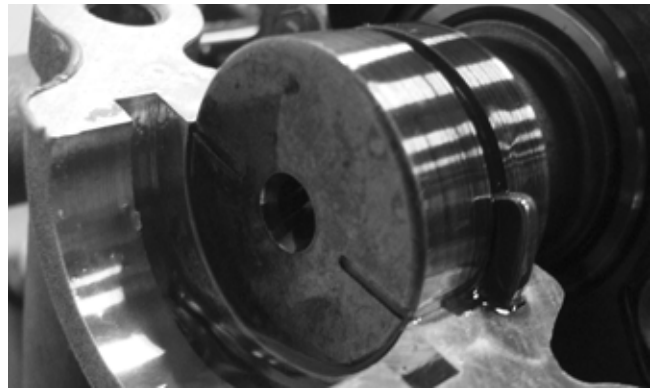

FI720

■NOTE: At this point, oil the camshaft bearings, cam lobes, and the three seating journals on the cylinder head.

■NOTE: Note the position of the alignment marks on the end of the camshaft. They must be parallel with the valve cover mating surface. If rotating the camshaft and sprocket is necessary for alignment, do not allow the crankshaft to rotate and be sure the cam lobes end up in the down position.

15. When the camshaft assembly is seated, ensure the following:
- Piston still at top-dead-center.
 - Camshaft lobes directed down (toward the piston).
 - Camshaft alignment marks parallel to the valve cover mating surface.
 - Recessed side of the sprocket directed toward the cam lobes.
 - Camshaft alignment pin and sprocket alignment hole (smallest) are aligned.

CAUTION

If any of the above factors are not as stated, go back to step 13 and carefully proceed.

16. Place the tab washer onto the sprocket making sure it covers the pin in the alignment hole.

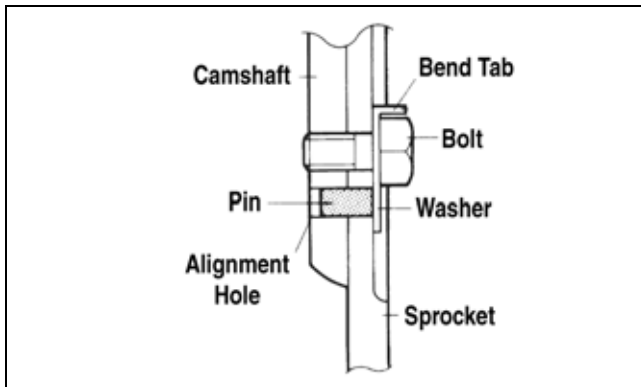

MD1363

CAUTION

Care must be taken that the tab washer is installed correctly to cover the alignment hole on the sprocket. If the alignment pin falls out, severe engine damage will result.

- Apply red Loctite #271 to the first cap screw securing the sprocket and tab washer to the camshaft; then install the cap screw and tab washer. Tighten cap screw only until snug.

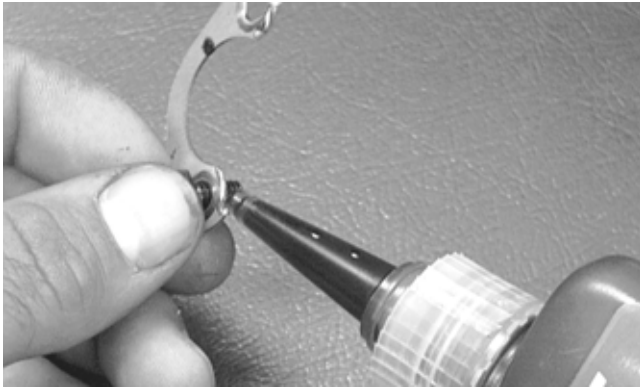

CC404D

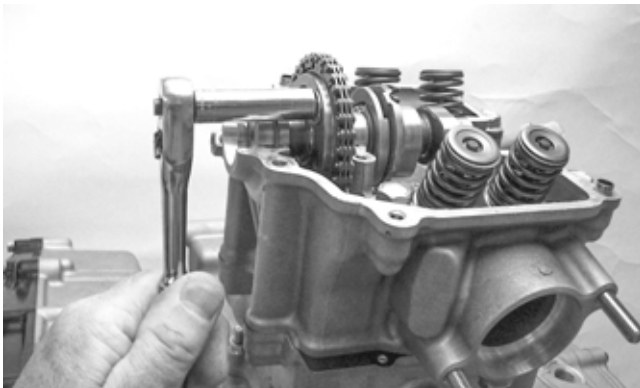

FI612

- Rotate the crankshaft until the second cap screw securing the sprocket to the camshaft can be installed; then install the cap screw (threads coated with red Loctite #271). Tighten to 11 ft-lb (15 N-m); then bend the tab to secure the cap screw.
- Rotate the crankshaft until the first cap screw (from step 17) securing the sprocket to the camshaft can be addressed; then tighten to 11 ft-lb (15 N-m). Bend the tab to secure the cap screw.

- Install the cylinder head plug with the cupped end facing the camshaft and the opening directed downwards.
- Place the cam chain tensioner assembly and gasket into the cylinder. Tighten to 10 ft-lb (13.6 N-m).
- Using a flat-blade screwdriver, turn the tensioner screw counterclockwise to apply tension to the cam chain; then install the cap screw plug and washer and tighten securely.

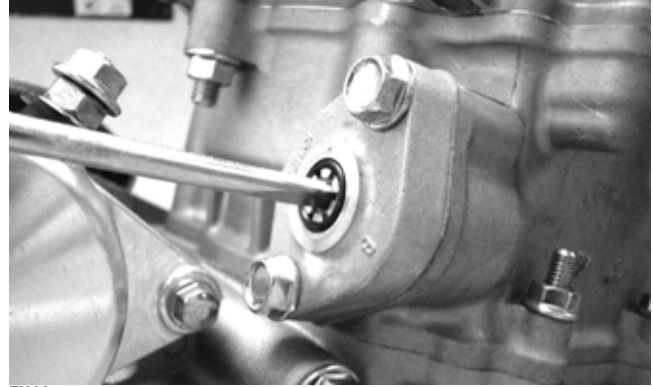

FI608

- Loosen the adjuster screw jam nuts; then loosen the adjuster screws on the rocker arms in the valve cover.
 - Apply a thin coat of Three Bond Sealant to the mating surface of the valve cover; then place the valve cover into position. Note that the two alignment pins are properly positioned.
- NOTE: At this point, the rocker arms and adjuster screws must not have pressure on them.
- Install the four top-side cap screws with rubber washers; then install the remaining cap screws. Tighten only until snug.



FI719

- In a crisscross pattern starting from the center and working outward, tighten the cap screws (from step 25) to 8 ft-lb (10.9 N-m).
- Adjust valve/tappet clearance (see Periodic Maintenance/Tune-Up).
- Place the two tappet covers with O-rings into position; then install and tighten the cap screws to 9 ft-lb (12.2 N-m).



FI602

29. Install the spark plug and tighten securely; then install the timing inspection plug.

Right-Side Components

■NOTE: For efficiency, it is preferable to remove and disassemble only those components which need to be addressed and to service only those components. The technician should use discretion and sound judgment.

AT THIS POINT

To service any one specific component, only limited disassembly of components may be necessary. Note the AT THIS POINT information in each sub-section.

■NOTE: The engine/transmission does not need to be removed from the frame for this procedure.

Removing Right-Side Components

- A. Water Pump
- B. Speed Sensor
- C. Magneto Cover/
Stator Assembly

1. Remove the coolant hose connecting the water pump to the cylinder; then remove the water pump cover.



FI538

2. Remove the water pump housing assembly noting the location of the longer cap screw. Account for a gasket and two alignment pins.

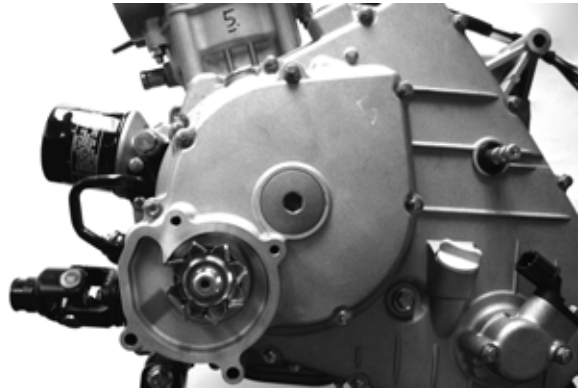

FI539

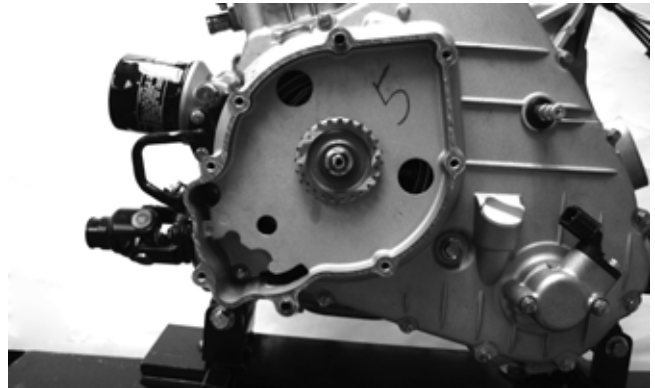

FI541

3. Remove two cap screws and the oil bolt securing the oil pressure relief line to the engine. Account for two crush washers and an O-ring.

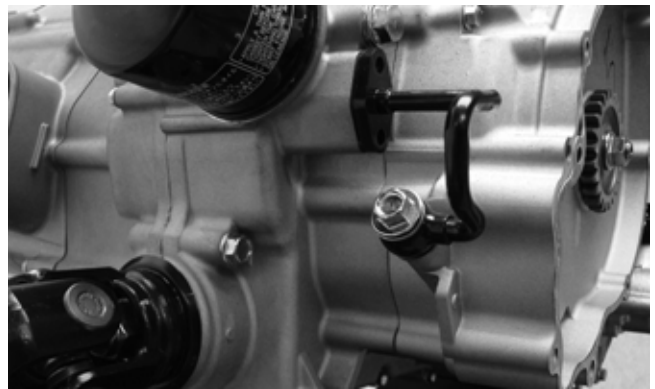

FI544

4. Remove the water pump drive gear; then remove the speed sensor housing assembly. Account for two alignment pins, a gasket, and two seal washers.

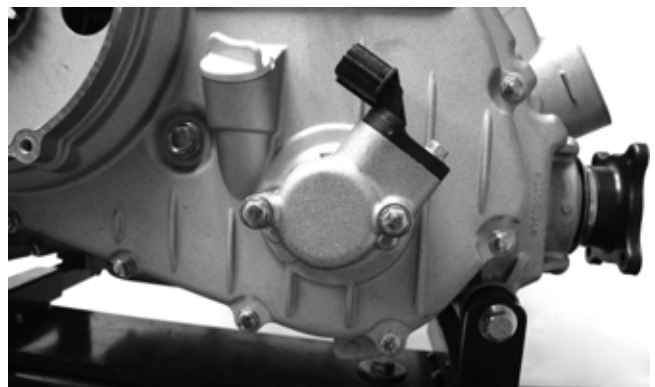

FI543

- Remove the cap screws securing the magneto cover to the crankcase. Note the location of the two internal cap screws and the two longer cap screws.

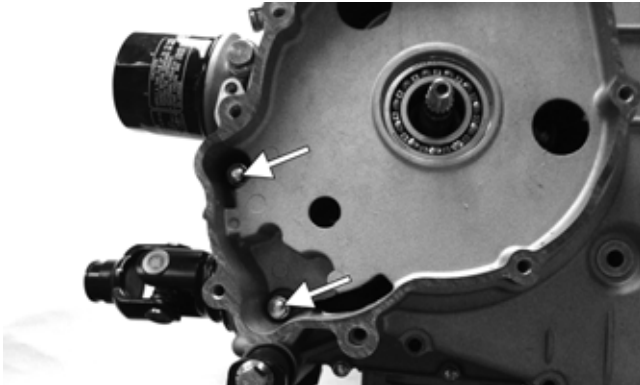

FI596A

- Remove the magneto cover and account for two alignment pins and the gasket.

D. Rotor/Flywheel

E. Starter Clutch/Gear

F. Starter Motor

■NOTE: Steps 1-6 in the preceding sub-section must precede this procedure.

- Remove the nut securing the rotor/flywheel on the crankshaft and install the crankshaft protector.

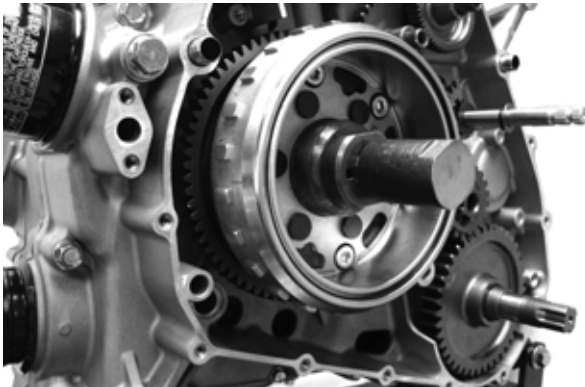

FI549

- Using the Magneto Rotor Remover Set, break the rotor/flywheel loose from the crankshaft; then remove the puller and crankshaft protector and remove the rotor/flywheel.



FI550

- Remove the flywheel key from the crankshaft; then remove the starter clutch gear.

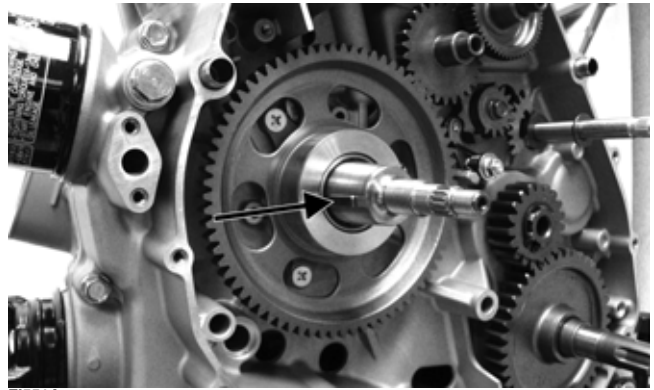

FI551A

- Remove starter idler gears and their respective shafts; then remove the starter motor. Account for an O-ring on the starter drive housing.



FI555

G. Shift Shaft

H. Drive Gear

■NOTE: Steps 1-10 in the preceding sub-sections must precede this procedure.

- Remove the shift shaft noting a washer on each end; then remove the cap screw securing the gear shift cam plate and remove the plate from the shaft.



FI559

- Remove the shift detent cam arm and spring.



FI560

13. Remove the snap ring securing the output drive gear to the output shaft and remove the gear noting that the hub flange is directed toward the crankcase.



FI564

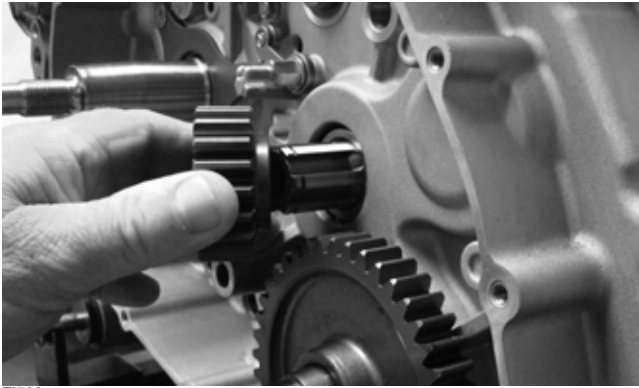

FI566

Servicing Right-Side Components

INSPECTING STARTER CLUTCH/GEAR

1. Place the starter clutch gear onto the rotor/flywheel and attempt to rotate the starter clutch gear clockwise. It should lock up to the rotor/flywheel. Rotate the gear counterclockwise and it should turn freely. If it moves or locks up both ways, the starter clutch must be replaced.
2. Inspect the starter clutch gear for chipped or missing teeth or discoloration/scoring of the clutch surface. Inspect the bearing for loose, worn, or discolored rollers. If bearing is damaged, it must be replaced.



FI569

3. Inspect the one-way bearing for chipped surfaces, missing rollers, or discoloration. If any of the above conditions exist, replace the starter clutch assembly.



FI572

REPLACING STARTER CLUTCH ASSEMBLY

1. Remove the cap screws securing the starter clutch assembly to the flywheel; then remove from the flywheel.



FI570

2. Thoroughly clean the rotor/flywheel; then install the new clutch and secure with the cap screws after applying a drop of red Loctite #271 to the threads. Tighten to 26 ft-lb (35.4 N-m) using a crisscross pattern. Make sure the one-way bearing is installed with the notches directed away from the rotor/flywheel.



FI576A



FI580

INSPECTING STATOR/MAGNETO COVER ASSEMBLY

1. Inspect the stator for burned or discolored wiring, broken or missing hold-down clips, or loose cap screws.
2. Inspect the bearings in the magneto housing for discoloration, roughness when rotated, and secure fit in bearing bores.
3. Inspect the oil pressure relief valve for evidence of metal chips or contamination. Do not disassemble the valve.



FI578

REPLACING STARTER GEAR BEARING

1. Support the starter clutch gear in a press making sure to support the hub around the entire circumference; then using a suitable bearing driver, press the bearing from the gear.



FI583

2. Thoroughly clean the gear hub; then apply a drop of green Loctite #620 to the bearing outer race and press into the gear hub until even with the lower chamfer radius.



FI588

REPLACING STATOR COIL/ CRANKSHAFT POSITION SENSOR

1. Remove the three cap screws securing the stator coil, two cap screws securing the crankshaft position sensor, and one cap screw from the harness hold-down.
2. Lift the rubber grommet out of the housing; then remove the stator coil/crankshaft position sensor. Account for and note the position of the harness hold-down under the crankshaft position sensor.

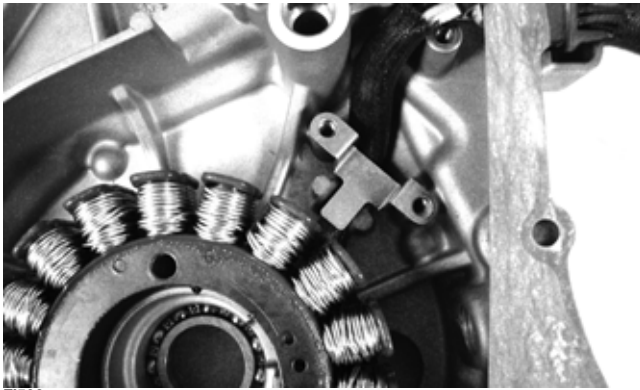

FI590

3. Install the new stator coil assembly and apply blue Loctite #243 to the three cap screws. Install and tighten to 13 ft-lb (17.7 N-m).
4. Place the stator wire harness hold-down into position; then install the crankshaft position sensor and secure with two cap screws. Tighten securely.
5. Install the upper cable hold-down and secure with a cap screw. Tighten securely.

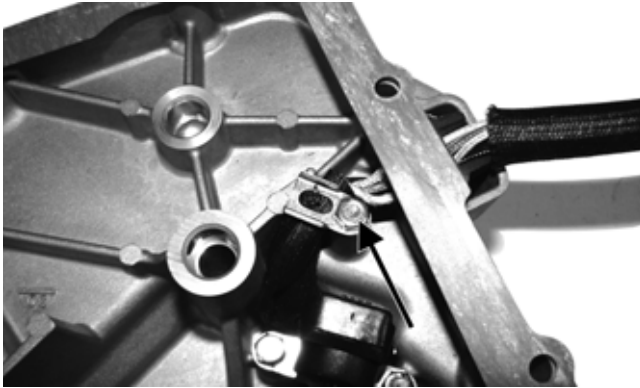

FI595A

REPLACING MAGNETO COVER BEARINGS

1. Using a suitable press and proper support, press the bearing from the housing as indicated (one from outside and one from inside).



FI593



FI594

2. Clean the bearing bores in the housing and inspect closely for cracks or shiny areas indicating bearing movement. Replace the housing if any of the above are evident.
3. With a drop of red Loctite #271 around the bearing bore, press a new bearing into the magneto cover until the bearing is firmly seated in the bearing bore.

Installing Right-Side Components

- A. Starter Clutch/Gear
- B. Rotor/Flywheel

1. If removed, place the crankshaft bearing retainer into position. Apply red Loctite #271 to the three cap screws. Install and tighten the three cap screws securely.



MD1122

2. Install the starter motor and tighten the two cap screws to 8 ft-lb (10.9 N-m).
3. Install the shift detent cam making sure the washer is installed.

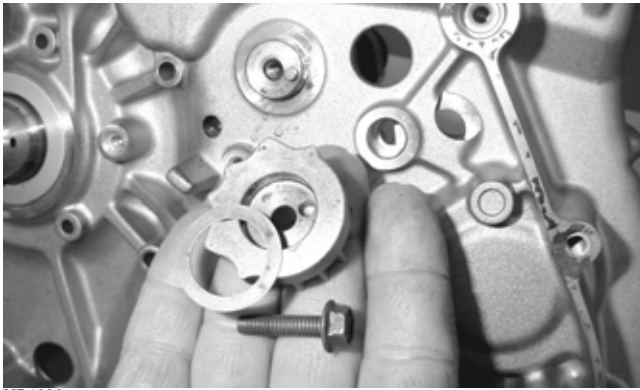

MD1086

4. Install the shift detent cam arm and spring.
5. Install the gear shift shaft assembly and washer making sure to align the alignment marks.



FI559

6. Install starter idler gears (1) and (2).



FI555A

7. Install the starter clutch gear onto the crankshaft; then install the rotor/flywheel key in the crankshaft.



FI551A

8. Install the rotor/flywheel and secure with the nut. Tighten to 107 ft-lb (145.1 N-m).

C. Magneto Cover

D. Water Pump

■NOTE: Steps 1-8 in the preceding sub-section must precede this procedure.

9. Install two alignment pins and place the magneto cover gasket into position. Install the magneto cover. Noting the different-length 6 mm cap screws and the location of the two internal cap screws, tighten the cap screws in a crisscross pattern to 8 ft-lb (10.9 N-m).

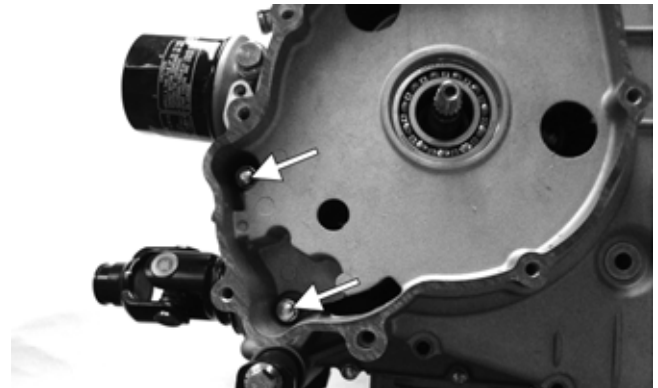

FI596A

10. Install the water pump drive gear and secure with the nut. Tighten to 28 ft-lb (38.1 N-m).

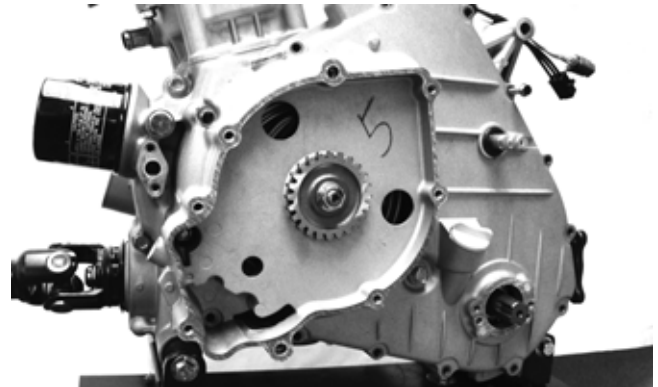

FI547

11. Install two alignment pins and a gasket on the magneto cover; then install the water pump housing assembly. Tighten the cap screws to 8 ft-lb (10.9 N-m).

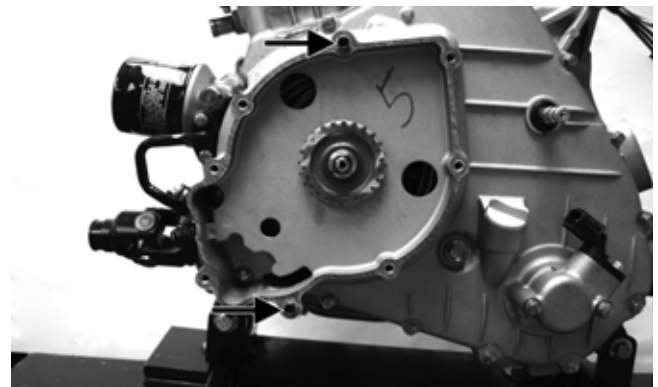

FI541A

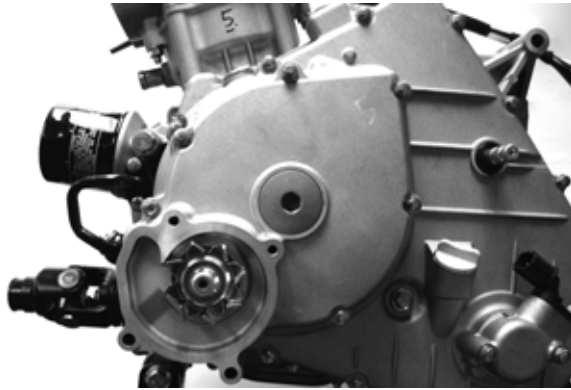

FI539

12. Install the water pump cover with a new O-ring and secure with the four cap screws. Tighten to 8 ft-lb (10.9 N-m).

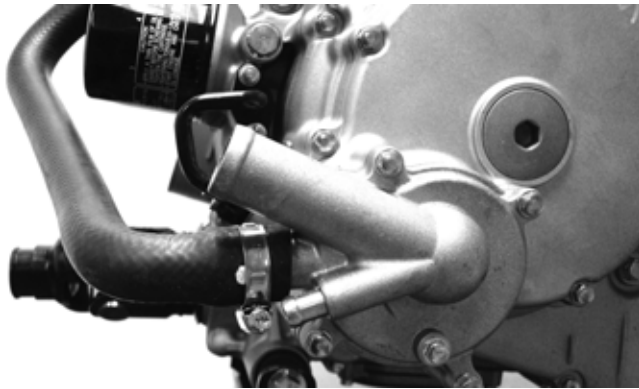

FI538

13. Connect the coolant hoses to the water pump and secure with the hose clamps. Tighten securely.

Left-Side Components

AT THIS POINT

To service center crankcase components only, proceed to Removing Right-Side Components.

■NOTE: For efficiency, it is preferable to remove and disassemble only those components which need to be addressed and to service only those components. The technician should use discretion and sound judgment.

AT THIS POINT

To service any one specific component, only limited disassembly of components may be necessary. Note the AT THIS POINT information in each sub-section.

■NOTE: The engine/transmission does not have to be removed from the frame for this procedure.

Removing Left-Side Components

- A. V-Belt Cover
- B. Driven Pulley
- C. Clutch Cover

1. Remove the cap screws securing the V-belt cover to the clutch cover; then remove the V-belt cover. Account for two alignment pins and a gasket.



FI721A

2. Inspect the bearings and input shaft bearing seals in the outer CVT cover. Rotate the inner races; if they do not rotate smoothly they must be replaced. Remove the snap ring and seal (secondary input shaft only); then using a suitable sized blind hole bearing puller, remove the bearing. Using a bearing driver the same size as the outside diameter of the outer race of the bearing, drive the new bearing into the CVT cover. Install a new snap ring and seal (secondary input shaft only).

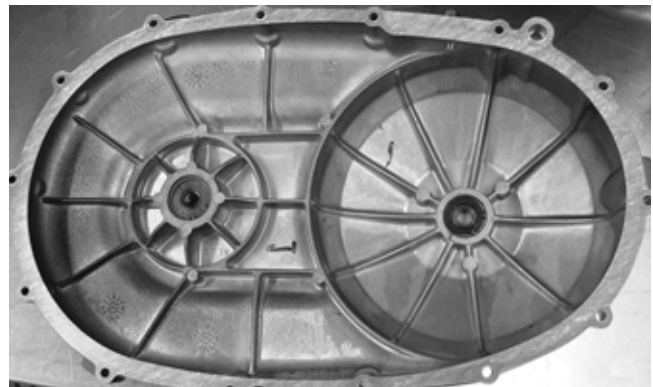

FI724

3. Mark the movable drive face and the fixed drive face for installing purposes; then remove the nut holding the movable drive face onto the crankshaft.

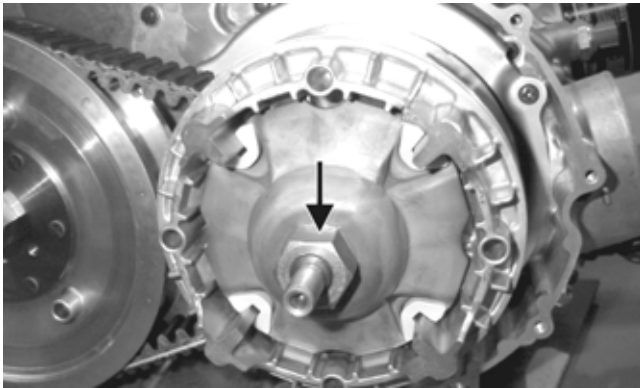

MD1033

4. Remove the movable drive face and spacer. Account for the movable drive face rollers and outer drive face cover.

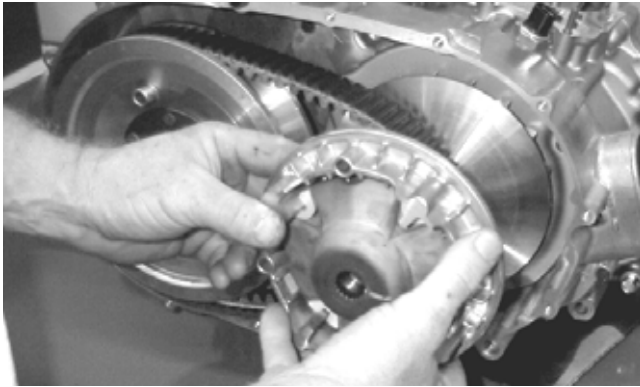

MD1035

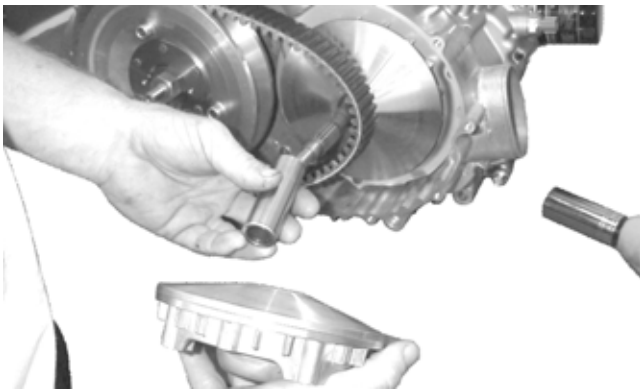

MD1034A

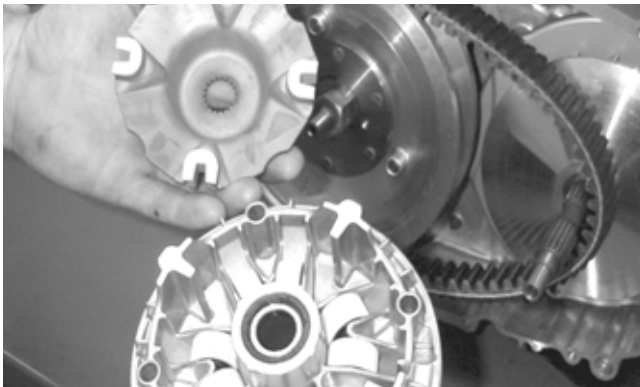

MD1036

5. Using a 6 mm cap screw threaded into the fixed driven face, spread the driven pulley by turning the cap screw clockwise; then remove the V-belt.

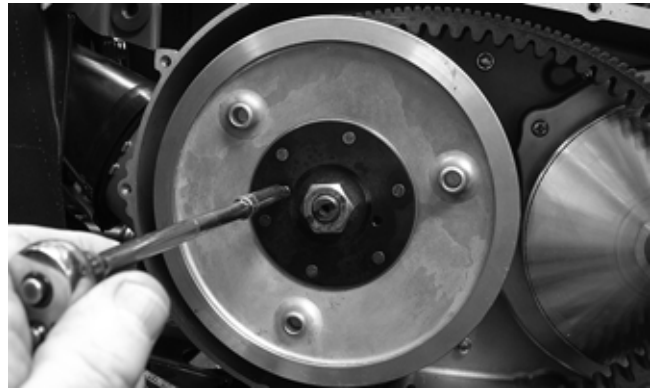

KC132

6. Remove the fixed drive face.

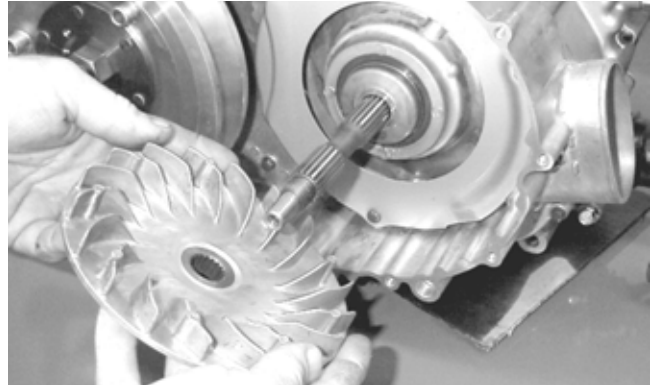

MD1094

7. Remove the nut holding the driven pulley assembly; then remove the driven pulley assembly.

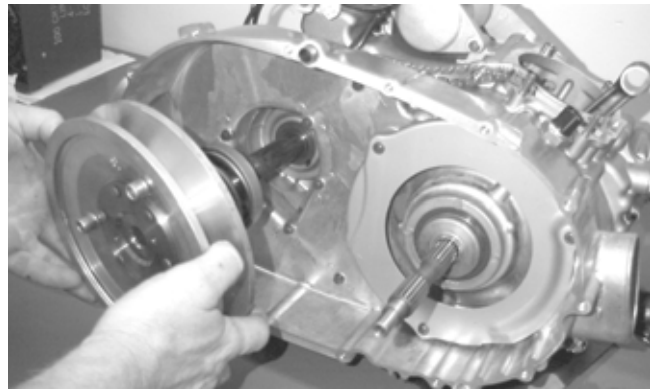

MD1068

8. Using an impact screwdriver, remove the three Phillips-head cap screws holding the air intake plate. Remove the air intake plate.

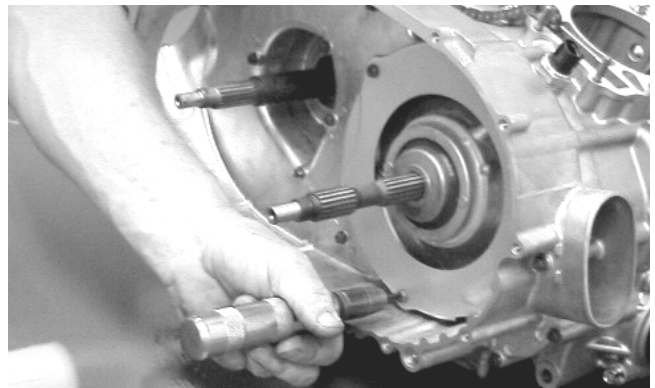

MD1092

9. Remove the cap screws holding the inner clutch cover onto the left-side crankcase half. Note the positions of the different-length cap screws for installing purposes.

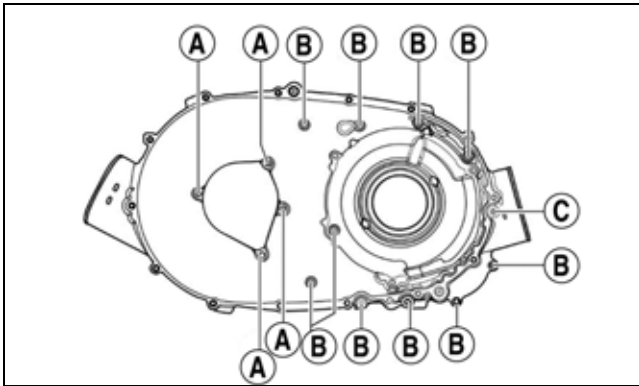

FI726A

10. Using a rubber mallet, loosen the clutch cover; then pull it away from the left-side crankcase half. Account for two alignment pins and gasket.

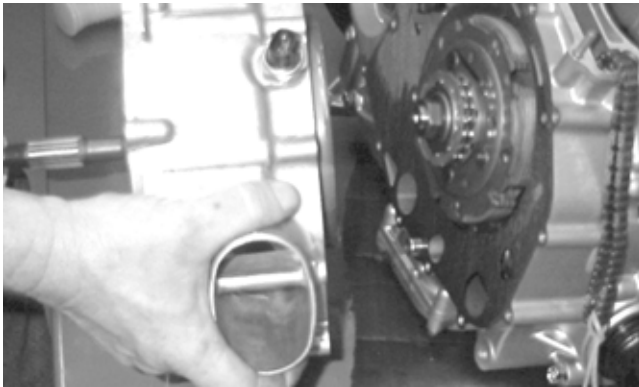

MD1115

11. Remove the clutch housing shaft spacer and inspect the O-ring installed inside of the spacer. Replace if necessary.



FI732

⚠ WARNING

Whenever a hydraulic press is used, a protective shield must be in place on the press and it must be utilized to avoid severe personal injury. Always use protective eye wear and clothing when using a hydraulic press.

12. Using a plastic mallet, drive the centrifugal clutch housing out of the inner clutch cover bearing. A press may be used to remove the centrifugal clutch housing.



FI733

13. Remove the two Phillips head screws securing the bearing retainers to the inner clutch cover housing. Remove the retainers. Using an appropriately sized bearing driver set against the inner race of the bearing, press the bearing out of the clutch cover. Note the orientation of the bearing for assembly purposes.



FI734



FI735

14. Using an appropriately sized seal driver, remove the seal from the inner clutch cover. Note the orientation of the seal for assembly purposes.

**D. Centrifugal Clutch Assembly
E. Oil Pump Drive Gear
F. Oil Pump Driven Gear**

■NOTE: Steps 1-10 in the preceding sub-section must precede this procedure.

11. Remove the one-way clutch noting the direction of the green dot or the word OUTSIDE for installing purposes.

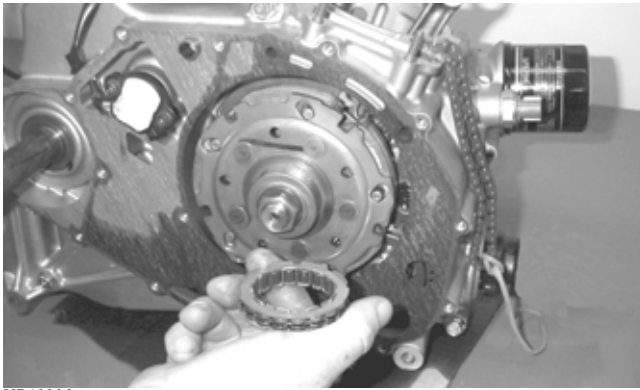

MD1286A

12. Remove the left-hand threaded nut holding the centrifugal clutch assembly.

CAUTION

Care must be taken when removing the nut; it has "left-hand" threads.

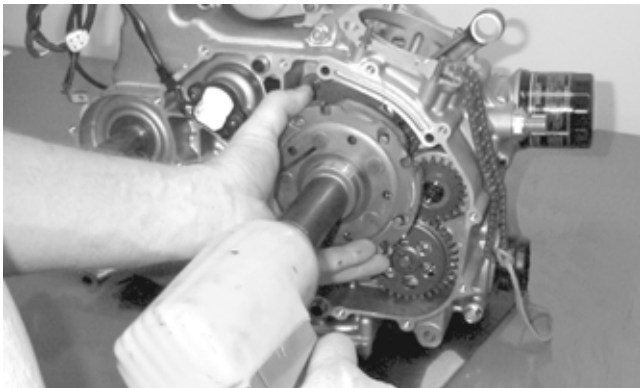

MD1014A



MD1016

13. Remove the cam chain.

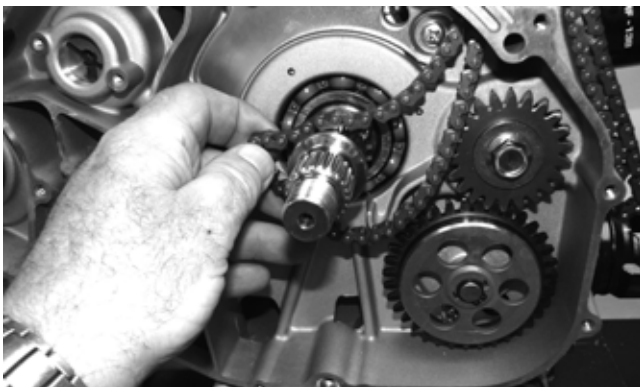

F1630

14. Remove the oil pump drive gear cap screw.

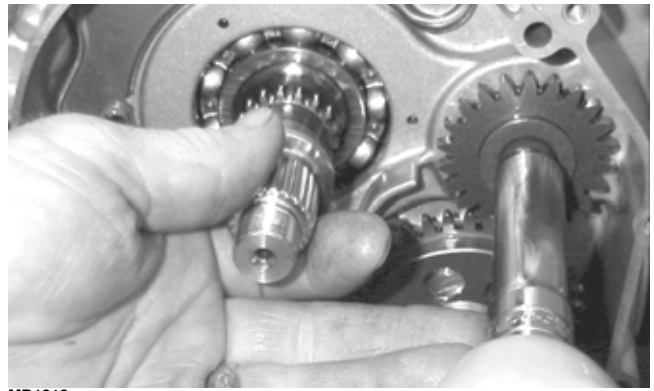

MD1018

15. Remove oil pump drive gear. Account for the pin.

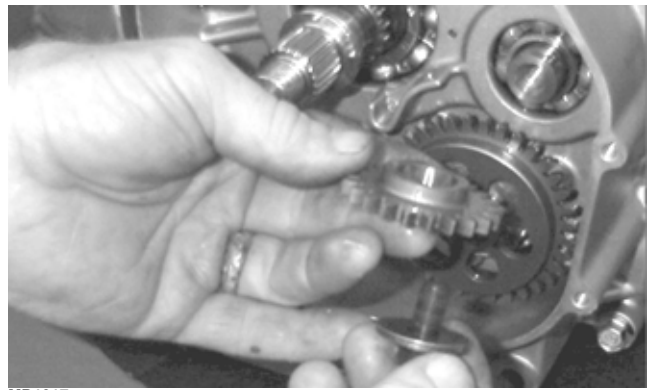

MD1017

16. Remove the snap ring holding the oil pump driven gear.



MD1019

■NOTE: Always use a new snap ring when installing the oil pump driven gear.

17. Remove oil pump driven gear. Account for the drive pin and thrust washer.

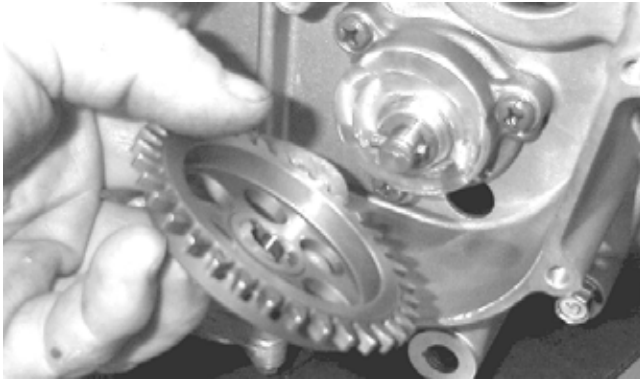

MD1020

AT THIS POINT

To service clutch components, see Servicing Left-Side Components sub-section.

G. Oil Pump/Oil Strainer

■NOTE: Steps 1-17 for the removal of items A through F in the preceding sub-sections must precede this procedure.

- Remove three cap screws holding the oil pump and remove the oil pump. Account for two alignment pins.

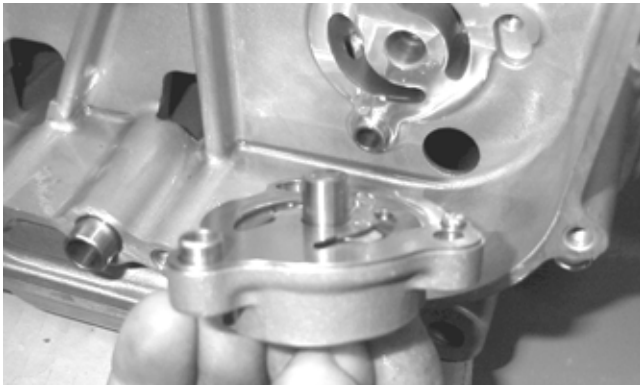

MD1060

- Remove the four cap screws securing the oil strainer cap; then remove the Phillips-head screws securing the oil strainer. Account for the O-ring.



MD1337



MD1208

AT THIS POINT

To service center crankcase components only, proceed to Separating Crankcase Halves.

Servicing Left-Side Components

INSPECTING CENTRIFUGAL CLUTCH SHOE

Inspect the clutch shoe for uneven wear, chips, cracks, or discoloration. If wear is present, replace the clutch assembly.

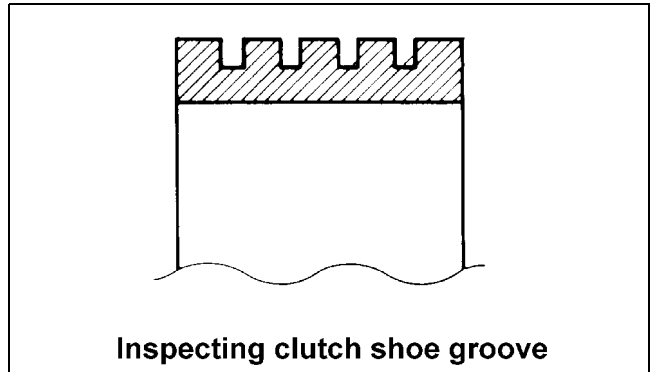

ATV1014

INSPECTING CENTRIFUGAL CLUTCH HOUSING

- Inspect the clutch housing for burns, marks, scuffs, cracks, scratches, or uneven wear.
- If the housing is damaged in any way, the housing must be replaced.

INSPECTING PRIMARY ONE-WAY DRIVE

- Place the one-way clutch onto the clutch shoe assembly with the green dot or the word "OUTSIDE" directed away from the clutch shoe.

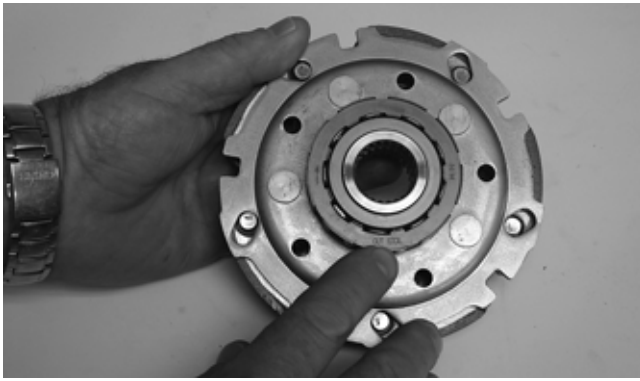

KC330

2. Place the clutch housing onto the clutch shoe/one-way clutch.

■NOTE: It will be necessary to rotate the clutch housing counterclockwise to properly seat the one-way clutch.



KC331A

3. Check that the clutch shoe can only be rotated counterclockwise in respect to the clutch housing. If the clutch shoe locks up or turns in both directions, the one-way clutch must be replaced.

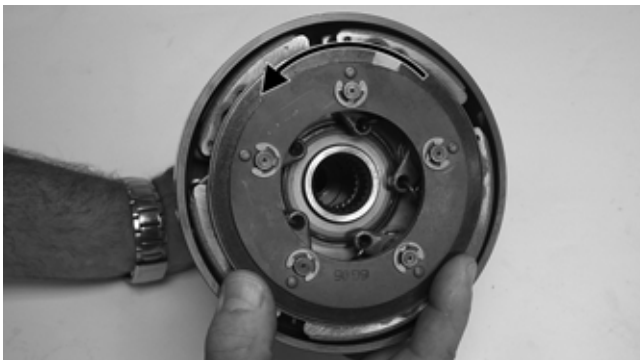

KC332A

INSPECTING OIL PUMP

1. Inspect the pump for damage.
2. It is inadvisable to remove the screw securing the pump halves. If the oil pump is damaged, it must be replaced.

■NOTE: The oil pump is only serviceable as an assembly.

INSPECTING DRIVE CLUTCH ASSEMBLY

1. Slide the sheave plate out of the movable drive sheave. Make note of each drive face plate damper orientation before removing. Check for excessive wear, warping or any cracks. Replace as necessary. Check the internal splines of the sheave plate for excessive or abnormal wear. Inspect the roller surface of the sheave plate for abnormal wear or pitting. Replace as necessary.

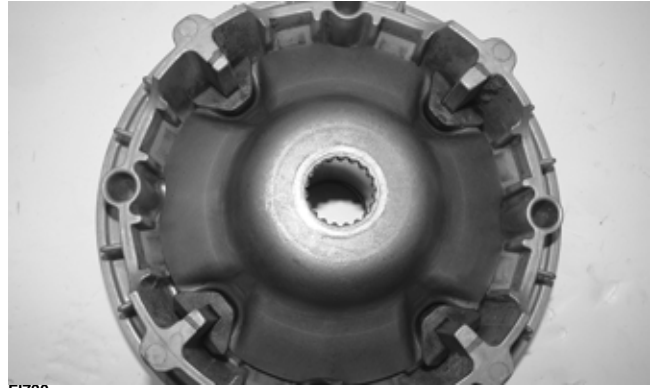

FI730

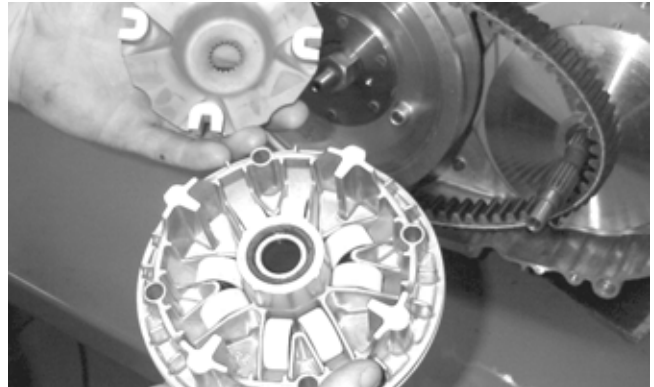

MD1036



FI731

2. Note the roller locations and orientation; then remove the rollers. Check for flat spots or abnormal or excessive wear.



FI727

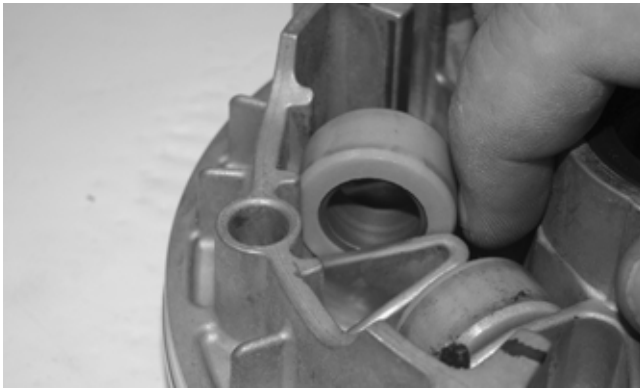

FI728

3. Check the seals on both sides, internal bushing of the movable drive sheave and surface of the spacer. Replace as necessary. Check the fixed drive sheave internal splines for excessive wear. Check for any broken cooling fins and replace as necessary.



FI729

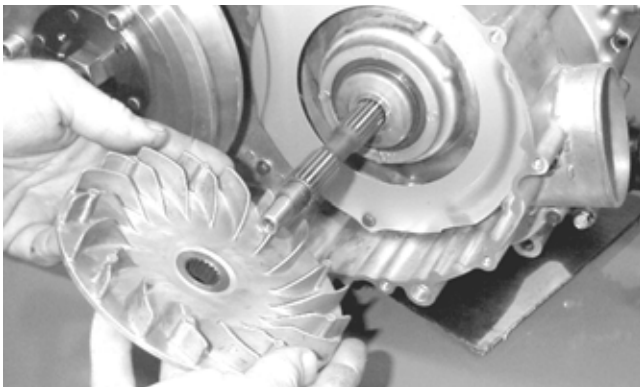

MD1094

DRIVEN PULLEY ASSEMBLY

■NOTE: The driven pulley assembly is only serviceable as an assembly.

Installing Left-Side Components

A. Oil Strainer/Oil Pump

1. Place the oil strainer into position beneath the crankcase. Tighten the Phillips-head screws securely.

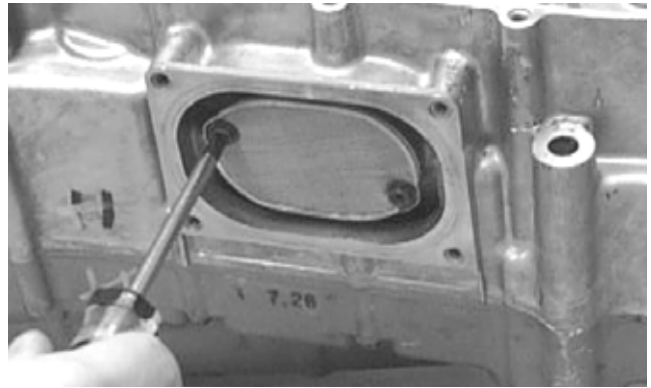

MD1337

2. Place the strainer cap into position on the crankcase making sure the O-ring is properly installed and secure with the four cap screws. Tighten the cap screws to 10 ft-lb (13.6 N-m); then install the oil drain plug and tighten to 16 ft-lb (21.8 N-m).



MD1208

3. Place two alignment pins and the oil pump into position on the crankcase and secure with the Phillips-head screws coated with red Loctite #271. Tighten to 8 ft-lb (10.9 N-m).

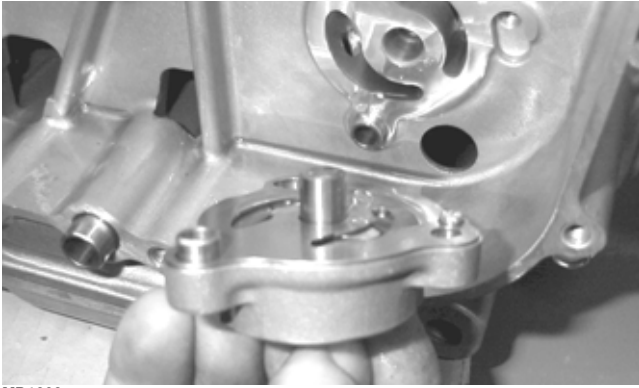

MD1060

4. Place the thrust washer and drive pin into position on the oil pump shaft, install the oil pump driven gear making sure the recessed side of the gear is directed inward, and secure with a new snap ring.

■NOTE: Always use a new snap ring when installing the oil pump driven gear.

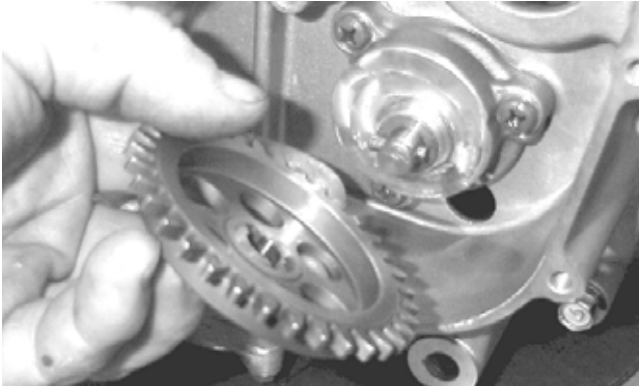

MD1020

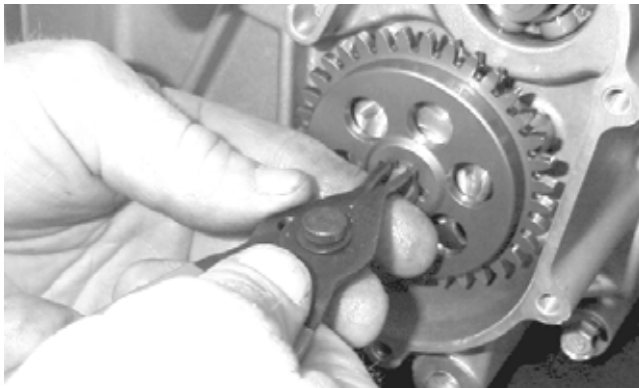

MD1019

5. Install the cam chain.

■NOTE: Keep tension on the cam chain to avoid damaging the crankcase boss.

6. Place the pin into position, install the oil pump drive gear, and tighten the cap screw (coated with red Loctite #271) to 63 ft-lb (85.7 N-m).

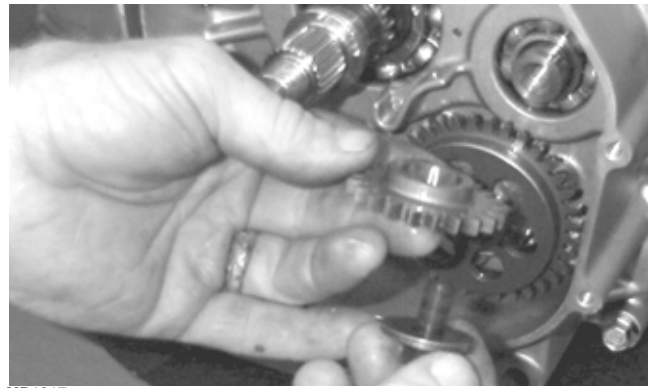

MD1017

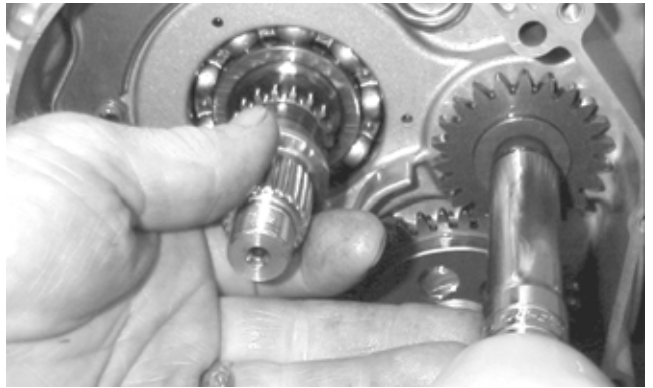

MD1018

7. Install the cam chain. Engage the cam chain to the drive teeth on the left side of the crankshaft. Pull the cam chain up and through the left side crankcase cover cam chain passage way.

CAUTION
Do not rotate the crankshaft as damage to the cam chain will occur.

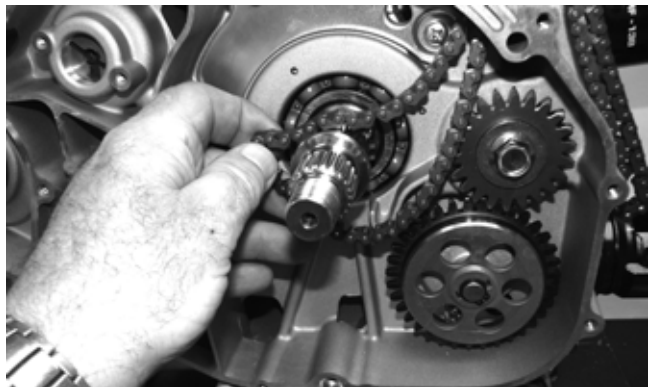

FI630

8. Install the clutch shoe assembly on the crankshaft; then install the flange nut (left-hand thread) (coated with red Loctite #271). Tighten to 147 ft-lb (199.3 N-m).

■NOTE: The flat side of the flange nut should be directed toward the clutch shoe.

CAUTION
Care must be taken when installing the flange nut; it has "left-hand" threads.

- Install the one-way clutch making sure that the green dot or the word OUTSIDE is directed away from the crankcase. There is also a directional arrow to indicate the correct orientation of installation on the centrifugal clutch.

■NOTE: When viewing the centrifugal clutch as shown below, the normal rotation of the clutch is clockwise.

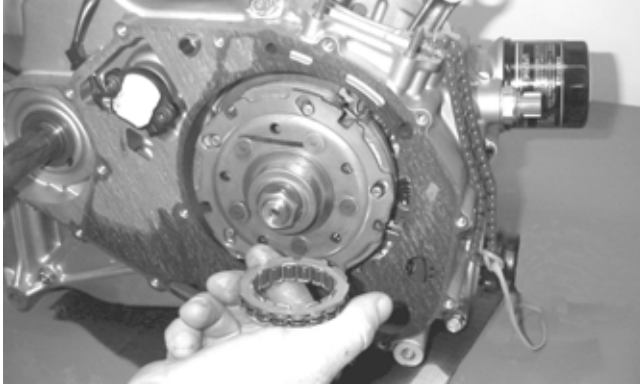

MD1286A

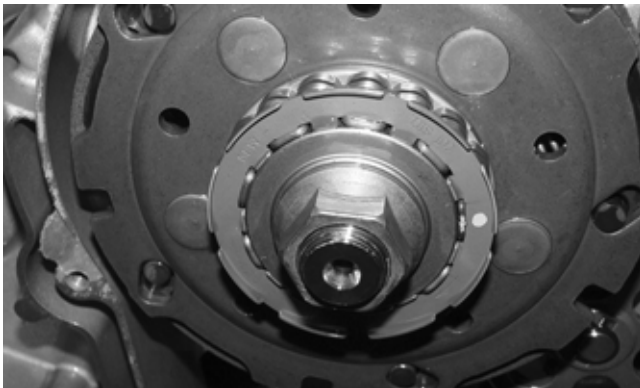

F1741

- B. Clutch Cover**
- C. Fixed Drive Face**
- D. Movable Drive Face**

■NOTE: Steps 1-9 in the preceding sub-section must precede this procedure.

- Grease the inner and out lips of the seal; then using an appropriately sized seal driver, drive a new seal into the inner clutch cover housing.
- On the opposite side of the clutch cover, verify the seal is fully seated.

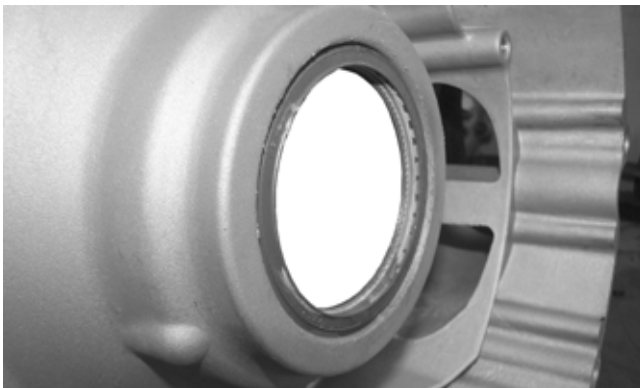

MD1115

- Place a new bearing into position with the sealed side of the bearing facing down; then using an appropriately sized bearing driver, press the bearing via the outer race into the inner clutch cover. Apply blue Loctite #243 to the threads of the two Phillips head screws and secure the two retainers.

⚠ WARNING

Whenever a hydraulic press is used, a protective shield must be in place on the press and it must be utilized. Otherwise severe bodily damage can occur. Always use protective eye wear and clothing when using a hydraulic press.

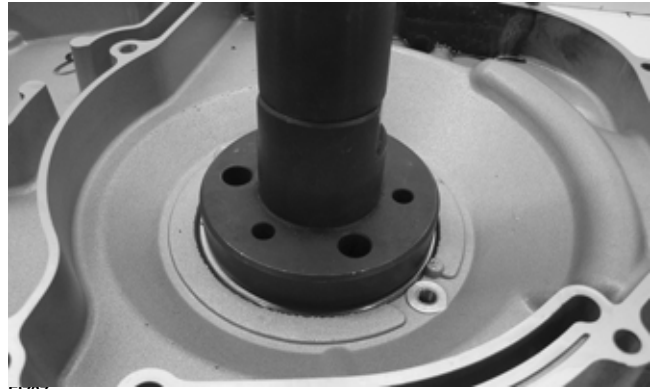

F1737



F1734

- Lubricate the inner race of the centrifugal clutch housing bearing with engine oil; then using a bearing driver and ball peen hammer, drive the clutch housing into the bearing until it fully seats.



F1738

- With a new O-ring installed into the spacer, place the spacer over the centrifugal clutch housing shaft and fully seat it into the inner clutch cover seal.

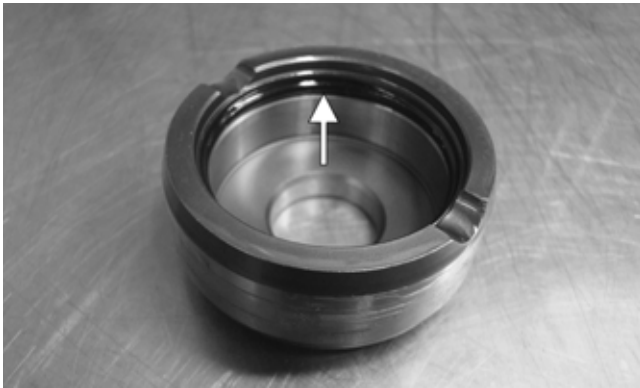

FI739A

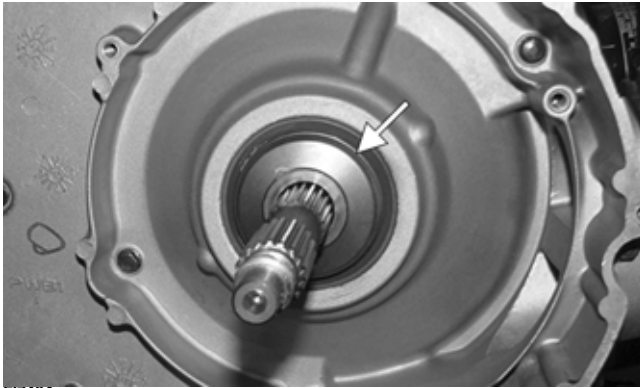

FI740A

6. Install two alignment pins and place the clutch cover gasket into position. Install the inner clutch cover.

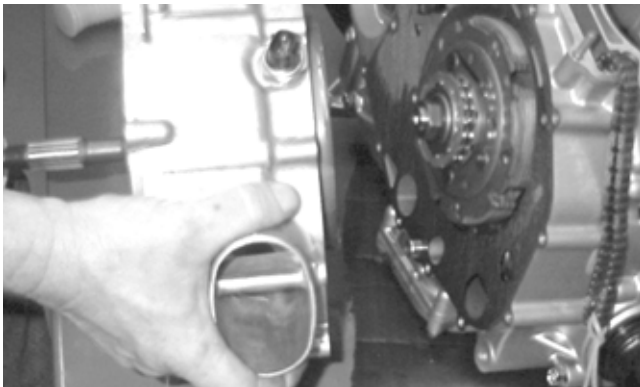

MD1115

7. Tighten the clutch cover cap screws (A), (B), and (C) to 8 ft-lb (10.9 N-m).

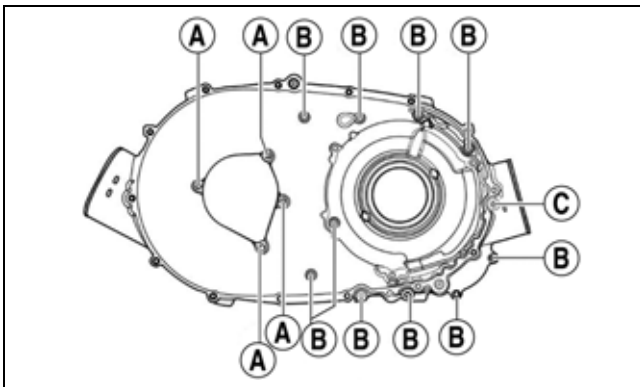

FI726A

8. Install the air intake plate. Apply red Loctite #271 to the threads of the three Phillips-head cap screws; then install and tighten securely.

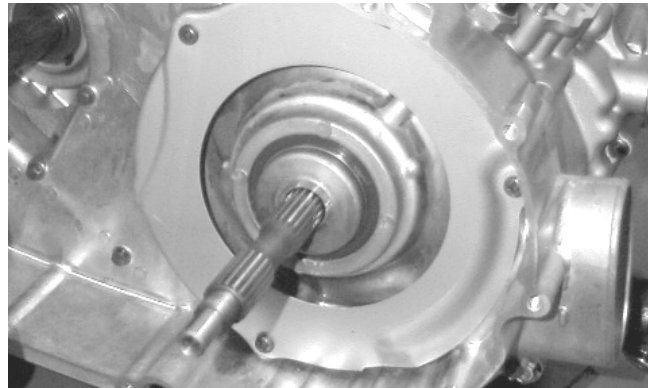

MD1342

9. Place the driven pulley assembly into position and secure with the nut (threads coated with red Loctite #271). Tighten to 85 ft-lb (115.6 N-m).

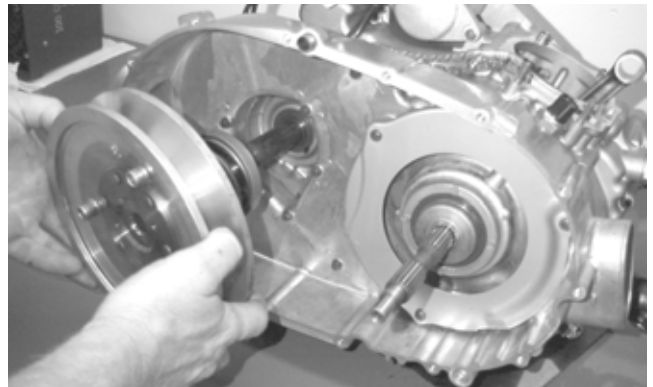

MD1068



FI742

10. Slide the fixed drive face assembly onto the front shaft.

11. Spread the faces of the driven pulley by threading a V-belt cover cap screw into the fixed driven face and tightening until the faces open sufficiently to allow the V-belt to drop into the pulley approximately 3/4 in. (19 mm).

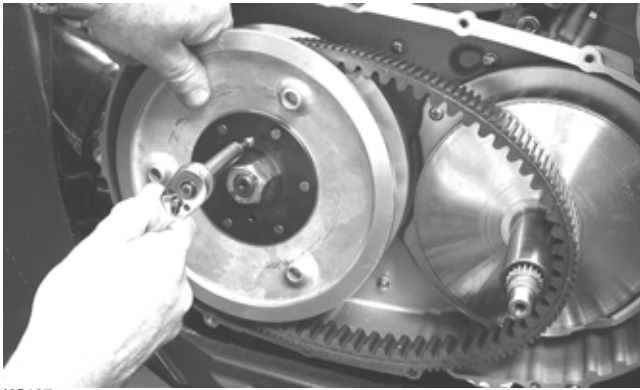

KC137

■NOTE: The arrows on the V-belt should point in direction of engine rotation.

12. Making sure the movable drive face rollers are in position, pinch the V-belt together near its center and slide the spacer and movable drive face onto the shaft.

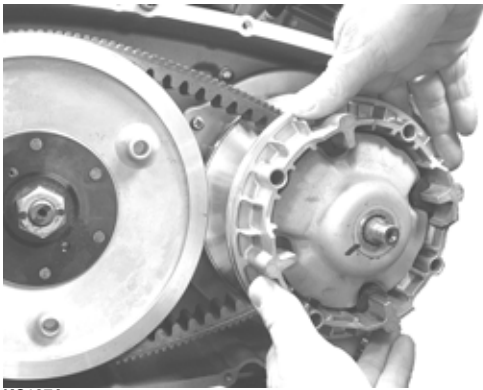

KC127A

13. Coat the threads of the nut with red Loctite #271; then making sure the splines of the clutch shaft protrude through the cover plate, secure with the nut and tighten to 85 ft-lb (115.6 N-m).

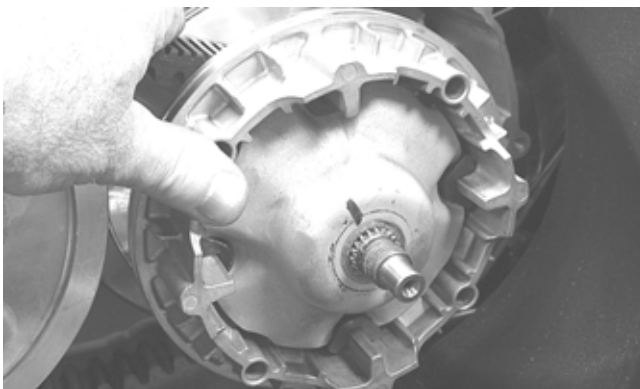

KC138A

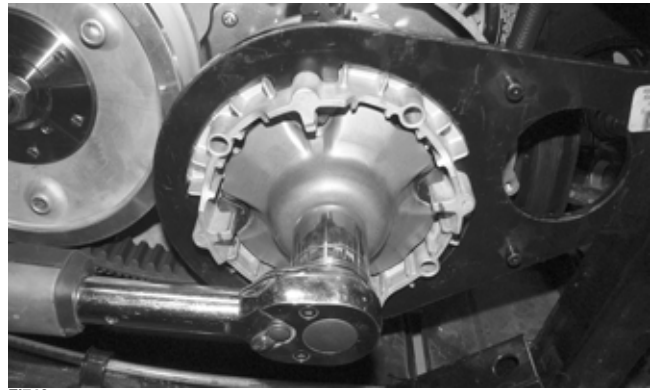

FI743

■NOTE: At this point, the cap screw can be removed from the driven pulley face.

14. Rotate the V-belt and drive/driven assemblies until the V-belt is flush with the top of the driven pulley.
15. Install two alignment pins and place a new V-belt cover gasket into position on the inner clutch cover; then place the outer clutch cover into position. In a crisscross pattern, tighten cap screws to 8 ft-lb (10.9 N-m).



FI721A

Center Crankcase Components

■NOTE: This procedure cannot be done with the engine/transmission in the frame. Complete Removing procedures for Top-Side, Left-Side, and Right-Side must precede this procedure.

■NOTE: For efficiency, it is preferable to remove and disassemble only those components which need to be addressed and to service only those components. The technician should use discretion and sound judgment.

Separating Crankcase Halves

1. Incrementally using a crisscross pattern, remove the left-side and right-side cap screws securing the crankcase halves noting the position of the different-sized cap screws for joining purposes.

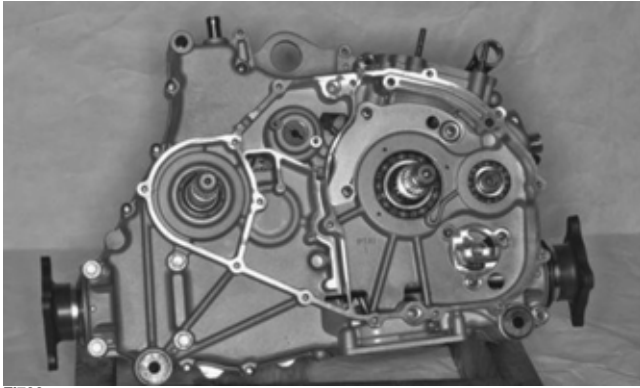

FI722

- Using Crankcase Separator/Crankshaft Remover and tapping lightly with a rubber mallet, separate the crankcase halves. Account for two alignment pins.

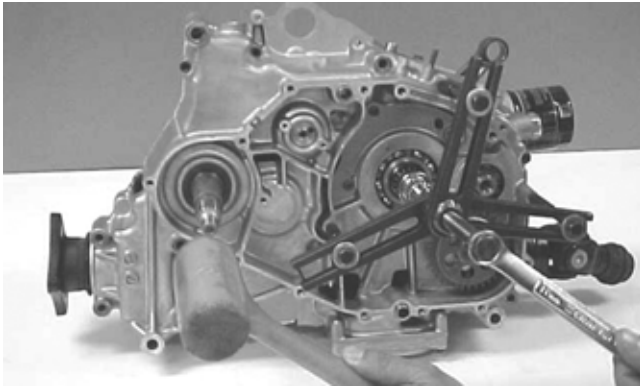

CC869

■NOTE: To keep the shaft/gear assemblies intact for identification, tap the shafts toward the left-side crankcase half when separating the halves.



MD1313

Disassembling Crankcase Half

■NOTE: To aid in installing, it is recommended that the assemblies be kept together and in order.

■NOTE: For steps 1-6, refer to illustration FI639A.

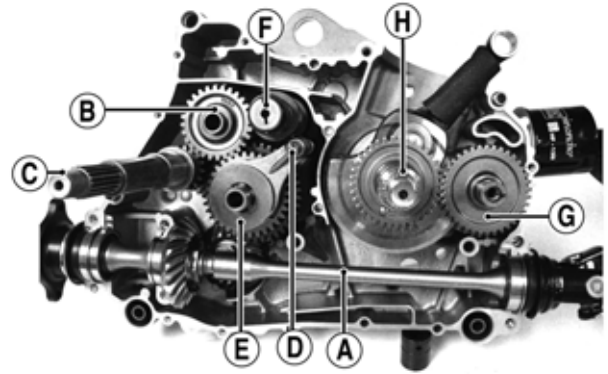

FI639A

- Remove the secondary driven shaft assembly (A) noting the location of the front and rear bearing locating pins and the center bearing locating ring.

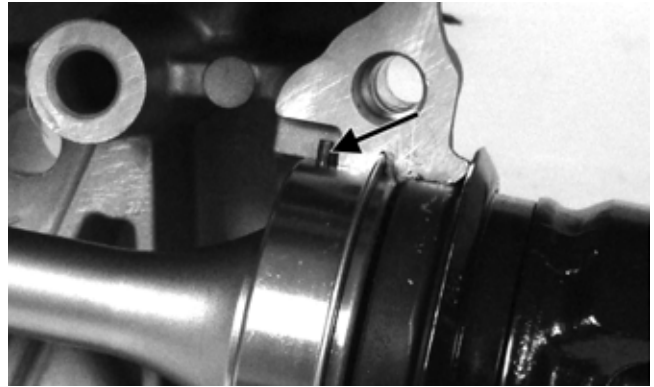

FI660A

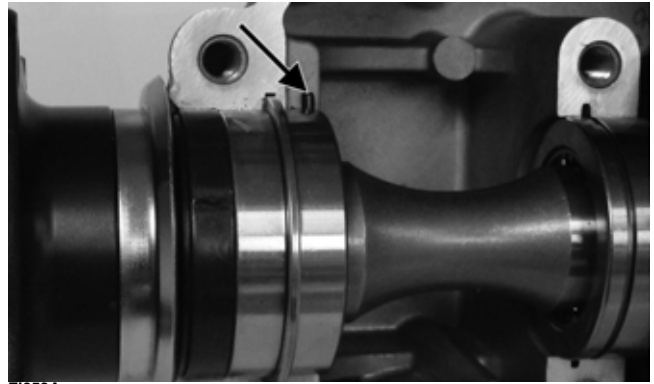

FI659A

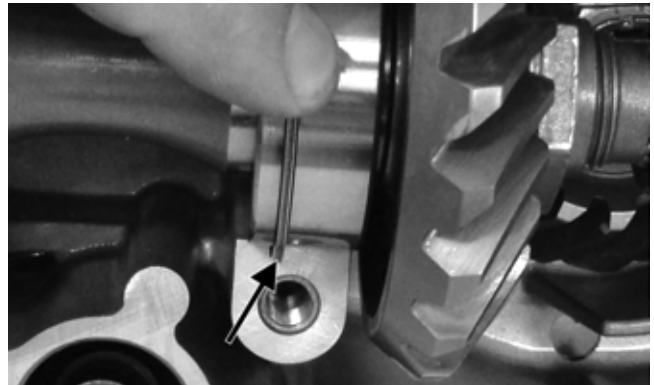

FI661A

- Remove the reverse idler assembly (B). Account for and note the location of the inner bushing (1), idler shaft (2), and outer washer (3).

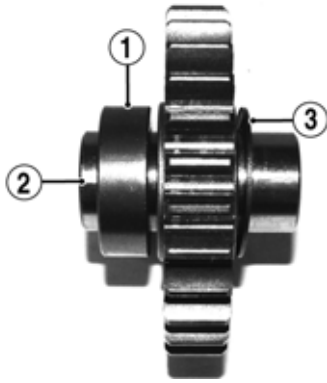

FI641A

3. Remove the driveshaft (C); then pull the shift fork locating shaft (D) out of the crankcase locating boss and allow the shift forks to disengage from the gear shift shaft (F).



FI646

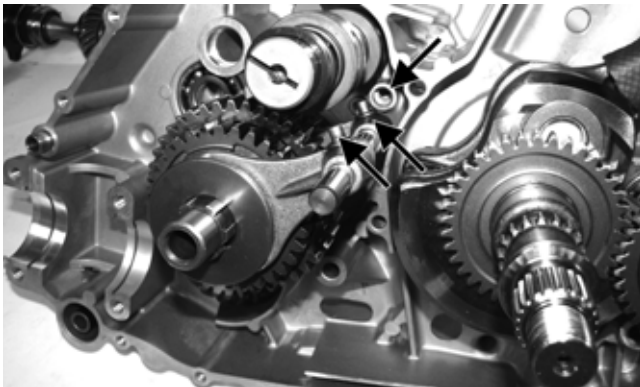

FI653A

4. Remove the gear shift shaft (F) noting the inner and outer washers.



FI650A

5. Remove the countershaft assembly (E) along with the shift fork assembly.

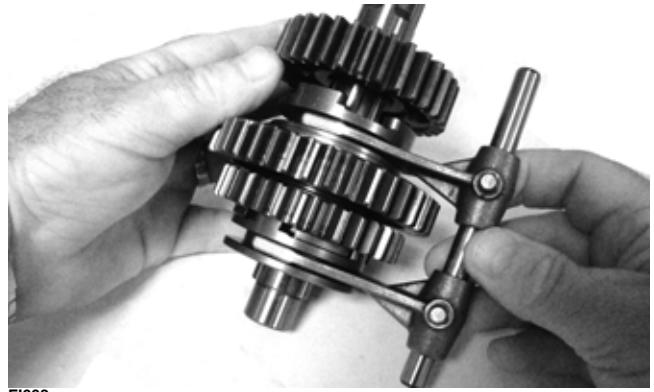

FI662

6. Remove the crank balancer driven gear (G) and account for a key; then remove the crankshaft balancer shaft.

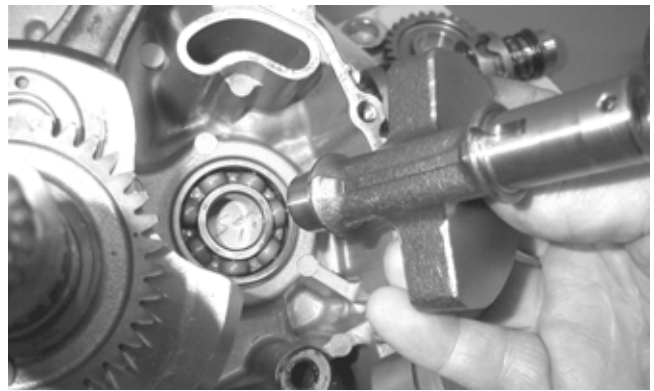

MD1024

7. Using Crankcase Separator/Crankshaft Remover with the appropriate crankshaft protector, remove the crankshaft.

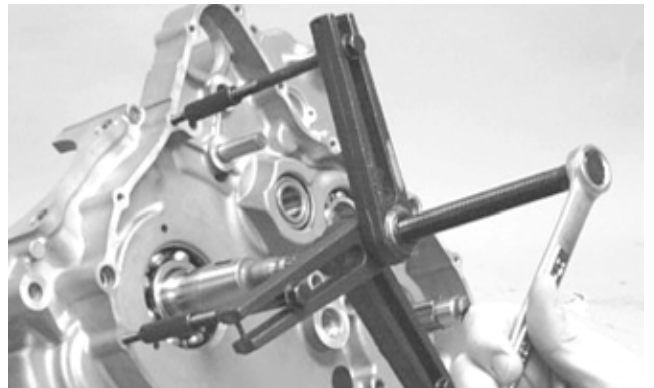

MD1330

CAUTION

Do not remove the remaining output shaft assembly unless absolutely necessary. If the shaft is removed, the shaft nut must be replaced with a new one and the shaft must be re-shimmed.

- Remove the secondary drive gear/secondary driven gear retaining nut. From inside the crankcase using a rubber mallet, drive out the output shaft assembly. Account for the output shaft, a shim, a washer, and the nut.

👉 AT THIS POINT

To service crankshaft assembly, see Servicing Center Crankcase Components sub-section.

Servicing Center Crankcase Components

SECONDARY GEARS

■NOTE: When checking and correcting secondary gear backlash and tooth contact, the universal joint must be secured to the front shaft or false measurements will occur.

Checking Backlash

■NOTE: The rear shaft and bevel gear must be removed for this procedure. Also, always start with the original shims on the rear shaft.

- Place the left-side crankcase cover onto the left-side crankcase half to prevent runout of the secondary transmission output shaft.
- Install the secondary driven output shaft assembly onto the crankcase.
- Mount the indicator tip of the dial indicator on the secondary driven bevel gear (centered on the gear tooth).
- While rocking the driven bevel gear back and forth, note the maximum backlash reading on the gauge.
- Acceptable backlash range is 0.05-0.33 mm (0.002-0.013 in.).

Correcting Backlash

■NOTE: If backlash measurement is within the acceptable range, no correction is necessary.

- If backlash measurement is less than specified, remove an existing shim, measure it, and install a new thinner shim.
- If backlash measurement is more than specified, remove an existing shim, measure it, and install a thicker shim.

■NOTE: Continue to remove, measure, and install until backlash measurement is within tolerance. Note the following chart:

Backlash Measurement	Shim Correction
Under 0.05 mm (0.002 in.)	Decrease Shim Thickness
At 0.05-0.33 mm (0.002-0.013 in.)	No Correction Required
Over 0.33 mm (0.013 in.)	Increase Shim Thickness

Checking Tooth Contact

■NOTE: After correcting backlash of the secondary driven bevel gear, it is necessary to check tooth contact.

- Remove the secondary driven output shaft assembly from the left-side crankcase half.
- Clean the secondary driven bevel gear teeth of old oil and grease residue.
- Apply a thin, even coat of a machinist-layout dye to several teeth of the gear.
- Install the secondary driven output shaft assembly.
- Rotate the secondary driven bevel gear several revolutions in both directions.
- Examine the tooth contact pattern in the dye and compare the pattern to the illustrations.

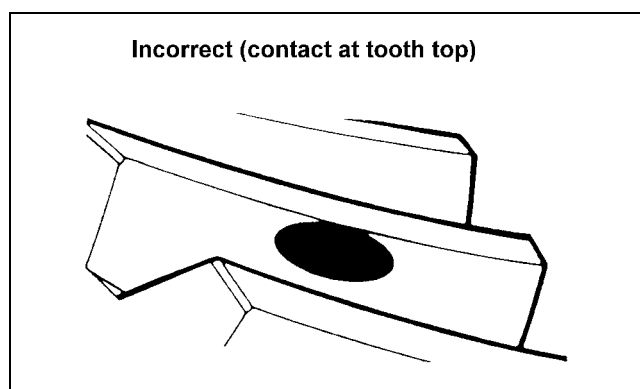

ATV-0103

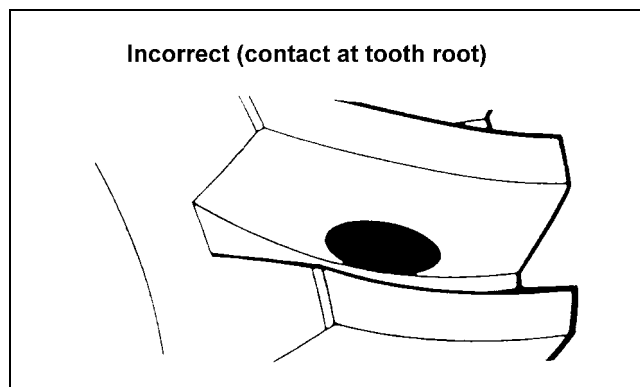

ATV-0105

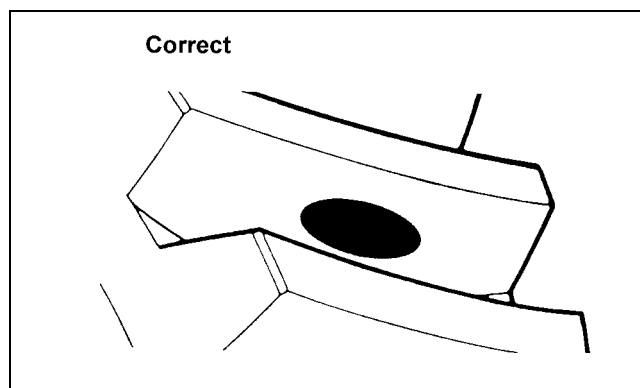

ATV-0104

Correcting Tooth Contact

■NOTE: If tooth contact pattern is comparable to the correct pattern illustration, no correction is necessary.

If tooth contact pattern is comparable to an incorrect pattern, correct tooth contact according to the following chart:

Tooth Contact	Shim Correction
Contacts at Top	Decrease Shim Thickness
Contacts at Root	Increase Shim Thickness

■NOTE: To correct tooth contact, steps 1 and 2 (with NOTE) of “Correcting Backlash” must be followed and the above “Tooth Contact/Shim Correction” chart must be consulted.

CAUTION

After correcting tooth contact, backlash must again be checked and corrected (if necessary). Continue the correcting backlash/correcting tooth contact procedures until they are both within tolerance values.

CRANKSHAFT ASSEMBLY

■NOTE: The crankshaft and connecting rod is only serviceable as an assembly.

Measuring Connecting Rod (Small End Inside Diameter)

1. Insert a snap gauge into the upper connecting rod small end bore; then remove the gauge and measure it with micrometer.

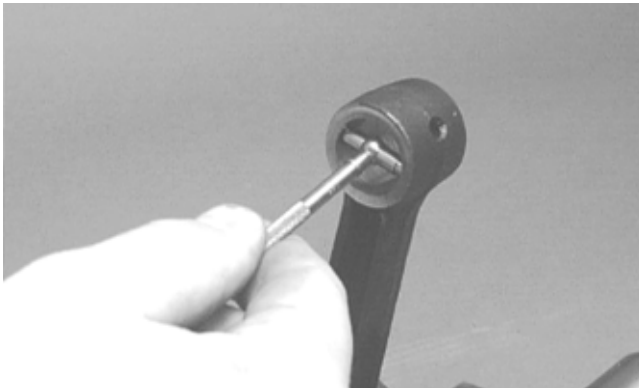

CC290D

2. Maximum diameter must not exceed specifications.

Measuring Connecting Rod (Small End Deflection)

1. Place the crankshaft on a set of V-blocks and mount a dial indicator and base on the surface plate. Position the indicator contact point against the center of the connecting rod small end journal.
2. Zero the indicator and push the small end of the connecting rod away from the dial indicator.
3. Maximum deflection must not exceed specifications.

Measuring Connecting Rod (Big End Side-to-Side)

1. Push the lower end of the connecting rod to one side of the crankshaft journal.

2. Using a feeler gauge, measure the gap between the connecting rod and crankshaft journal.

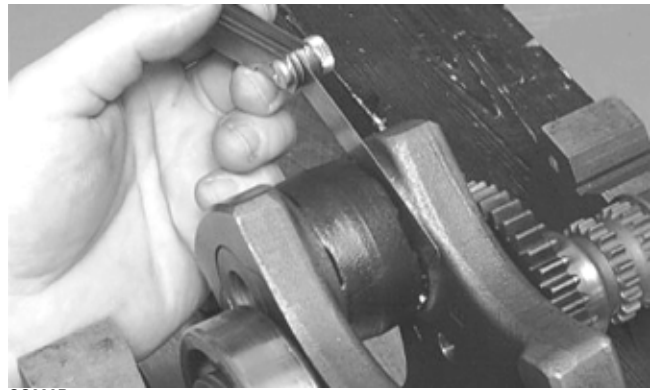

CC289D

3. Acceptable gap range must be within specifications.

Measuring Crankshaft (Runout)

1. Place the crankshaft on a set of V blocks.
2. Mount a dial indicator and base on the surface plate. Position the indicator contact at point 1 of the crankshaft.

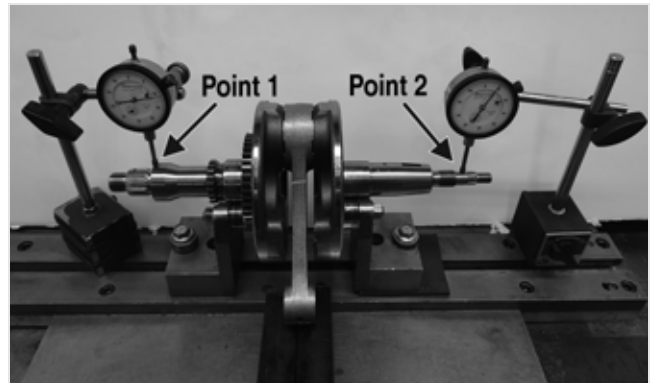

H1-003A

3. Zero the indicator and rotate the crankshaft slowly.

CAUTION

Care should be taken to support the connecting rod when rotating the crankshaft.

4. Maximum runout must not exceed specifications.

■NOTE: Proceed to check runout on the other end of the crankshaft by positioning the indicator contact at point 2 and following steps 3-4.

Measuring Crankshaft (Web-to-Web)

1. Using a calipers, measure the distance from the outside edge of one web to the outside edge of the other web.

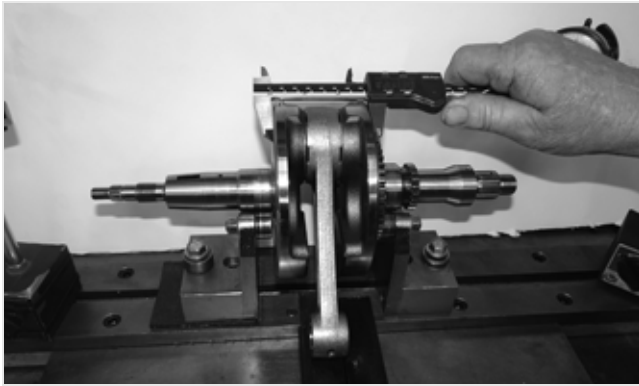

H1-006

2. Acceptable width range must be within specifications.

COUNTERSHAFT

CAUTION

When disassembling the countershaft, care must be taken to note the direction each major component (dog, gear) faces. If a major component is installed facing the wrong direction, transmission damage may occur and/or the transmission will malfunction. In either case, complete disassembly and assembly will be required.

Disassembling

1. Remove the reverse driven gear dog; then remove the circlip securing the reverse driven gear.



FI663



FI664

2. Remove the splined washer; then remove the reverse driven gear along with the bearing and bushing.



FI665

3. Remove the low driven gear washer; then remove the low driven gear along with the bearing and bushing.



FI666



FI667

4. Remove the splined washer; then remove the circlip securing the high-low sliding dog. Remove the sliding dog.



FI668



F1669

5. Remove the circlip securing the high driven gear; then remove a washer, the high driven gear along with the bearing and bushing, and remove the high driven washer.



F1670



F1671

ASSEMBLING

1. With the high driven washer (1) on the countershaft, install the high driven gear bushing (3), bearings (2), and gear (4) on the countershaft; then install the washers (5) and secure with the snap-ring.

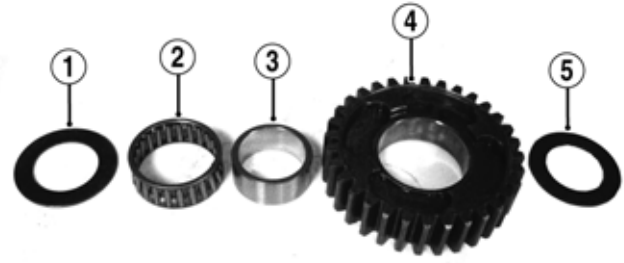

F1671A



F1670

2. Install the high/low shift dog (6) on the countershaft and secure with snap-ring (7); then install the splined washer (8).



F1668A

3. Install the low driven bushing (10), bearing (9), and gear (11) on the countershaft; then install splined washer (12).

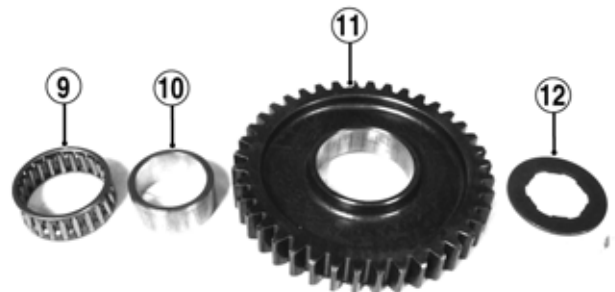

F1667A



FI666

- Place the reverse driven bushing (13) onto the shaft; then install the bearing (14), gear (15), and splined washer (16). Secure with a snap-ring.



FI665A



FI664

- Install the reverse dog on the shaft; then place the shift forks and shift shaft into position.



FI663

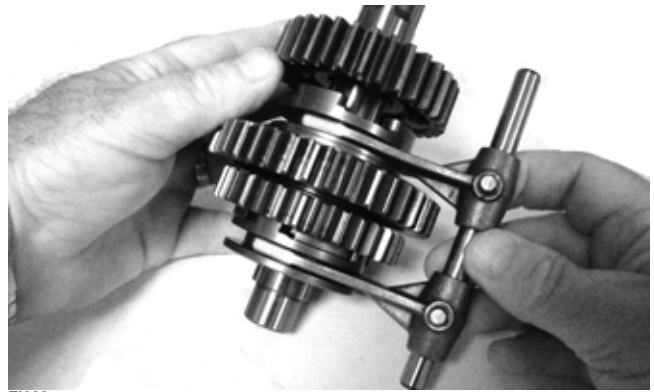

FI662

- NOTE: The countershaft assembly is now ready to be installed.

Assembling Crankcase Half

- NOTE: For ease of assembly, install components on the right-side crankcase half.

- NOTE: If the output shaft was removed, make sure that the proper shim is installed.

- Install the output shaft into the crankcase making sure the two gears, shim, washer, and nut are in the correct order.

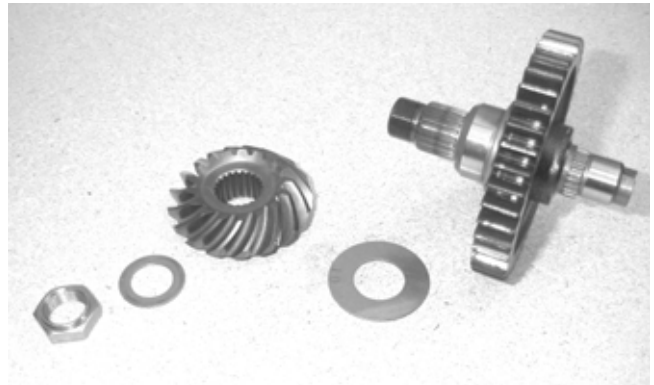

MD1199

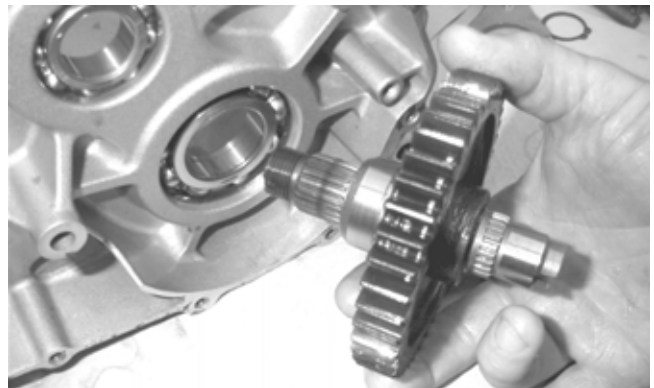

MD1079

- Install and tighten the output shaft flange nut to 59 ft-lb (80.2 N-m). Using a punch, peen the nut.

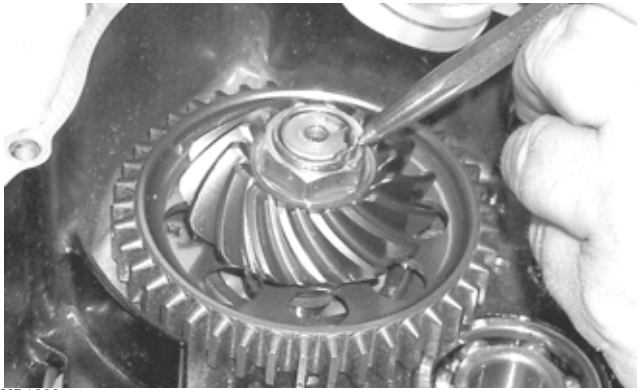

MD1333

3. Apply a liberal amount of oil to the crankshaft bearing. Using a propane torch, heat the bearing until the oil begins to smoke; then slide the crankshaft assembly into place.



MD1334

■NOTE: If heating the bearing is not possible, the crankshaft can be installed using a crankshaft installer.

4. Rotate the crankshaft so the counterweight is toward the rear of the engine. Install the crank balancer shaft.

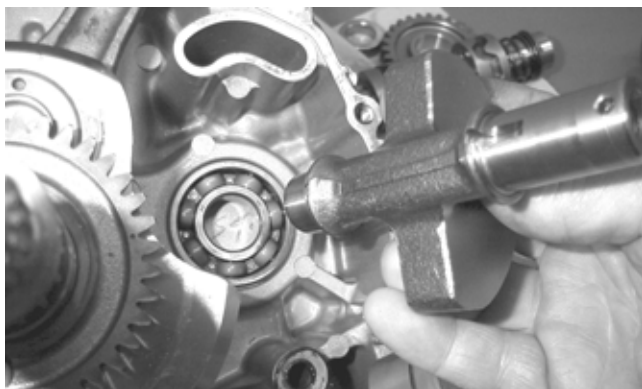

MD1024

5. Install the key in the crank balancer shaft; then install the gear and aligning the timing marks, slide the gear into place.



FI658

6. Align the shift cam fork slots with the shift fork shaft locating boss and with a washer on each end, install in the crankcase.

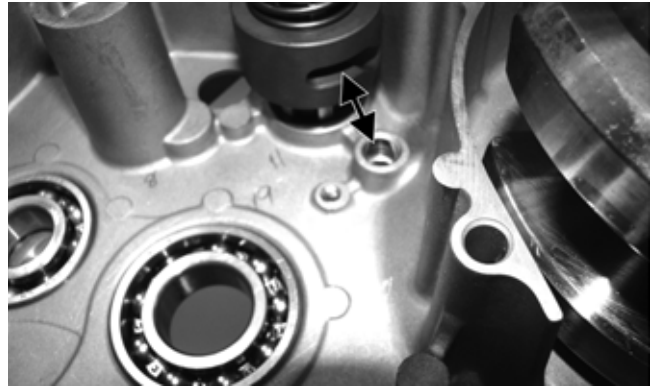

FI652A

7. Place the shift forks into position on the assembled countershaft and install into the crankshaft as an assembly.

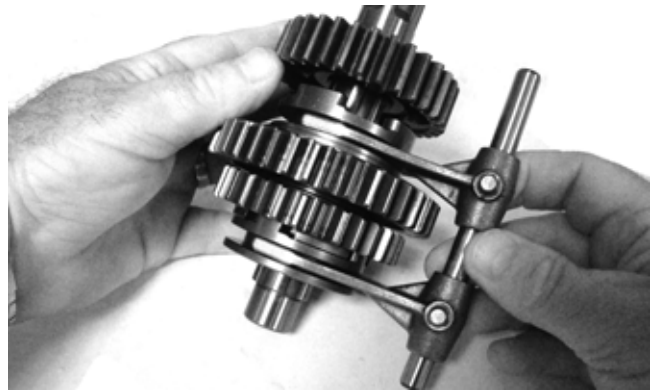

FI662



FI653

8. Align the shift forks to allow engagement with the shift cam; then engage the shift forks and slide the shift fork shaft into the locating boss in the crankcase.

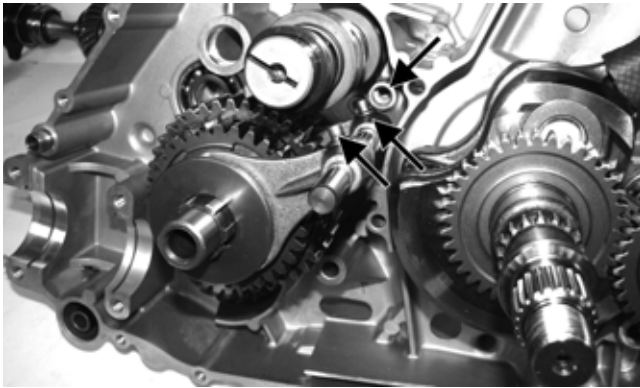

FI653A



FI645

11. Install the secondary output driveshaft assembly into the crankcase half making sure the front and rear bearing alignment pins are seated in the recesses; then install the center carrier bearing alignment C-ring.



FI655A

9. Install the input driveshaft.

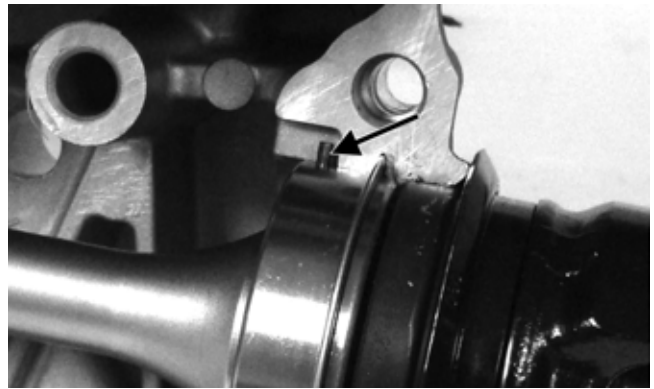

FI660A



FI646

10. Install the spacer (1), shaft (2), reverse idler gear, and washer (3).

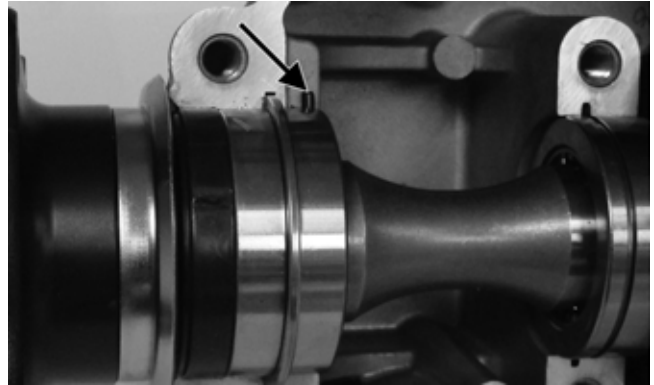

FI659A

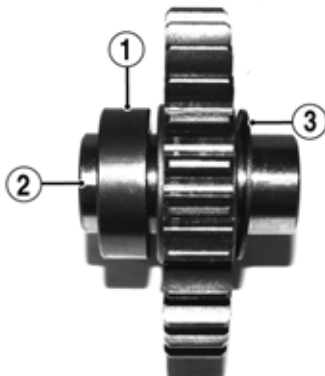

FI641A



FI661A

Joining Crankcase Halves

1. Verify that the two alignment pins (A) are in place and that both case halves are clean and grease free. Apply Loctite #5900 or suitable substitute sealant to the mating surfaces. Place the left-side half onto the right-side half.

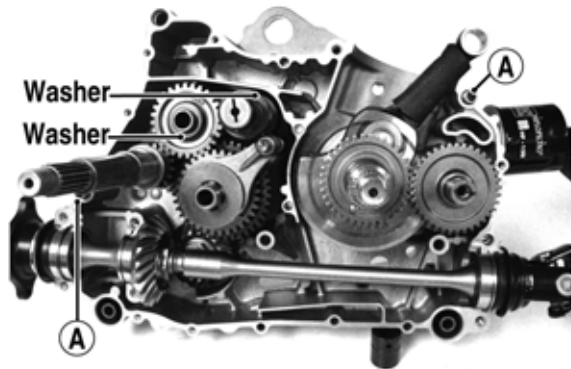

F1639B

■NOTE: Be sure to apply silicone to the inside radius of all cap screw locations and the entire surface of the internal cap screw bosses.

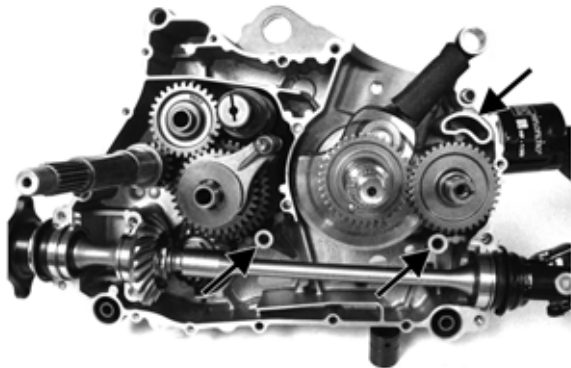

F1639D

2. Using a plastic mallet, lightly tap the case halves together until cap screws can be installed.
3. From the right side, install the crankcase cap screws noting the location of the different-sized cap screws; then tighten only until snug.

■NOTE: Rotate the shafts back and forth to ensure no binding or sticking occurs while tightening the cap screws.

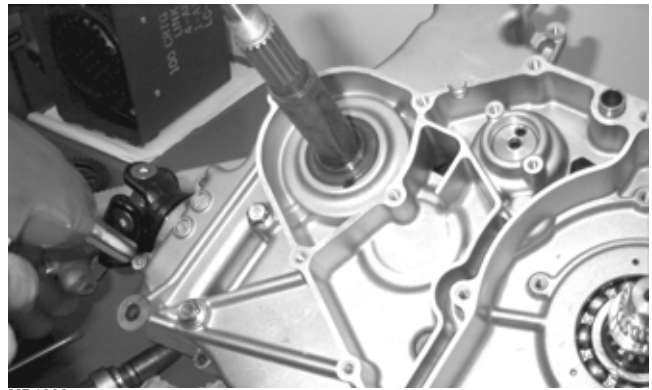

MD1008

4. From the left side, install the remaining crankcase cap screws; then tighten only until snug.

■NOTE: Rotate the shafts back and forth to ensure no binding or sticking occurs while tightening the cap screws.

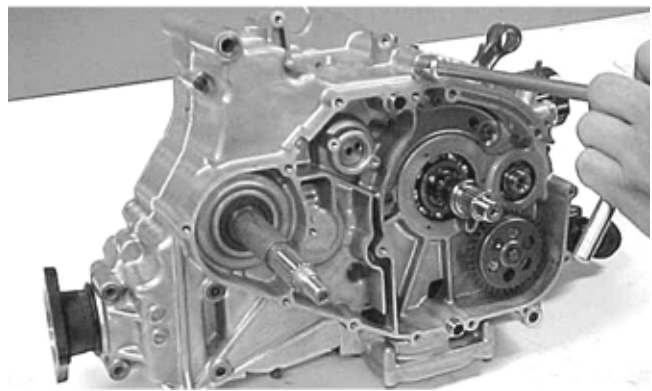

CC871

5. In a crisscross pattern, tighten the 8 mm cap screws until the halves are correctly joined; then tighten to 21 ft-lb (28.6 N-m).

■NOTE: Rotate the shafts back and forth to ensure no binding or sticking occurs.

6. In a crisscross pattern, tighten the 6 mm cap screws to 10 ft-lb (13.6 N-m).

■NOTE: Rotate the shafts back and forth to ensure no binding or sticking occurs.

⚠ AT THIS POINT

After completing center crankcase components, proceed to Installing Right-Side Components, to Installing Left-Side Components, and to Installing Top-Side Components.

Installing Engine/ Transmission

■NOTE: The manufacturer recommends new gaskets, patch-lock cap screws, lock nuts, and O-rings be installed whenever servicing the vehicle.

1. Install the engine bracket with weld nuts to the front of the engine using the through bolt and nut. Finger tighten only at this point. Install the rear engine bracket with threaded studs to the rear of the engine and install the through bolt and nut. Finger tighten only. Install both through bolts from the magneto side of the engine.
2. Using a suitable lifting sling and engine hoist, slowly lower the engine into the vehicle engaging the threaded studs of the rear engine mount bracket into the frame. Align the weld nuts on the front engine bracket to the mounting holes found in the frame.
3. Tighten the engine bracket, lock nuts, and cap screws to 25 ft-lb (34 N-m) each.

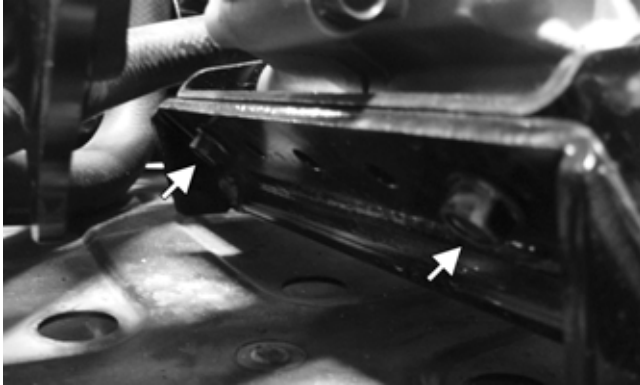

PK178A

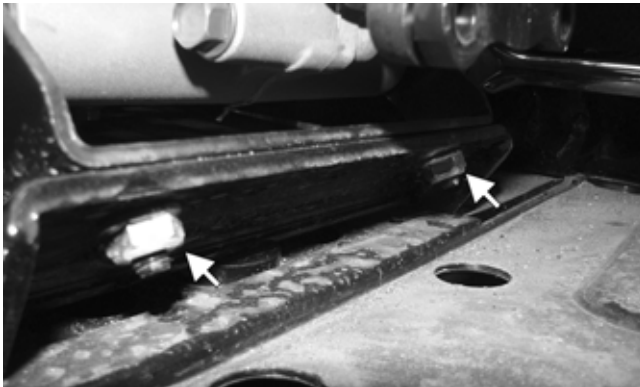

PK179A

4. While holding the through bolts with a suitable sized socket and breaker bar, tighten the lock nuts to 43.5 ft-lb (59 N-m).



PK180

5. Align the match marks made on the front and rear drive flange assemblies. Install the eight cap screws and tighten to 20 ft-lb (27.2 N-m).

6. Install the large and small diameter coolant return hoses to the water pump. Install the large and small diameter coolant outlet hoses to the cylinder head coolant fitting. Secure all clamps.

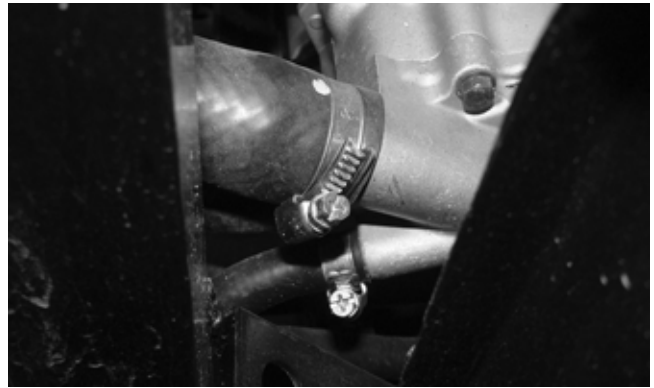

PK176



PK175

7. Connect the ACG, crank position sensor, speed sensor, and gear select switch. Install the shift cable into the bracket using the previously recorded set length (E); then using the adjustment nuts, secure the cable to the bracket. Align the punch marks; then install the gear shift arm to the shift shaft. Secure the cap screw.

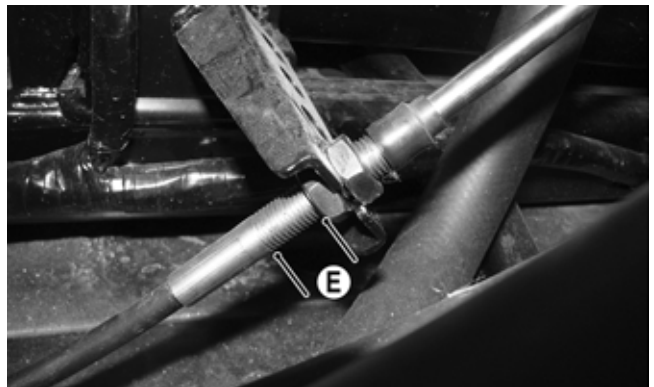

PK102A

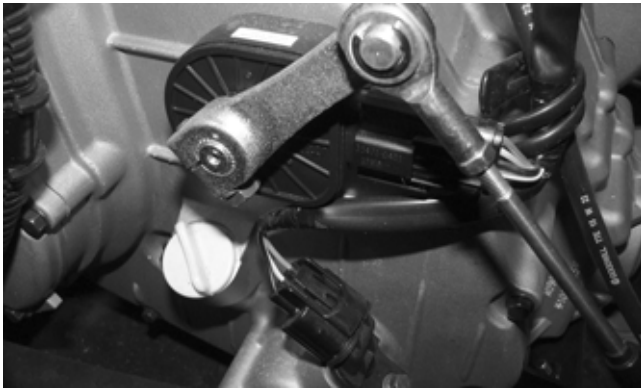

PK174

8. With the fuel injector O-ring in place, install the injector and fuel rail onto the cylinder head; then secure using the two cap screws. Secure the fuel line to the routing clamp located on the MAG side of the engine.

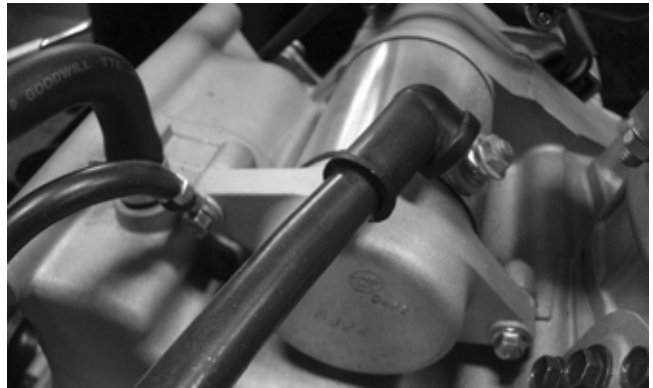

PK171

10. Place the throttle body into the intake boot and secure it with the clamp. Correctly route and secure the throttle cable using the routing clamps.



PK172

9. Place the starter cable onto the starter motor and secure it with the nut. Secure the engine ground cable to the engine using the front starter motor mount cap screw. Tighten securely.

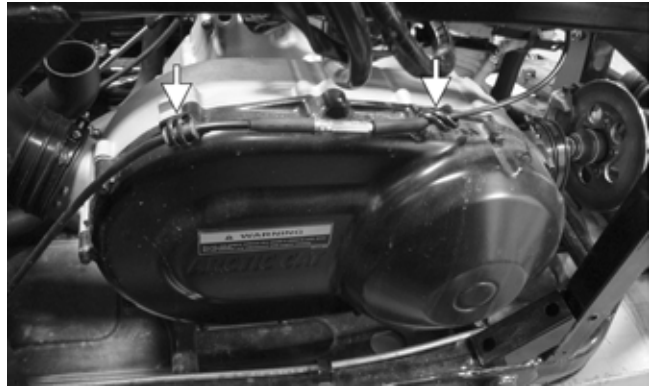

PK111A

11. Connect the coolant temperature (A), TPS (B), ISC (C), TMAP (D), and fuel injector (E) connectors. Place the spark plug cap onto the spark plug.

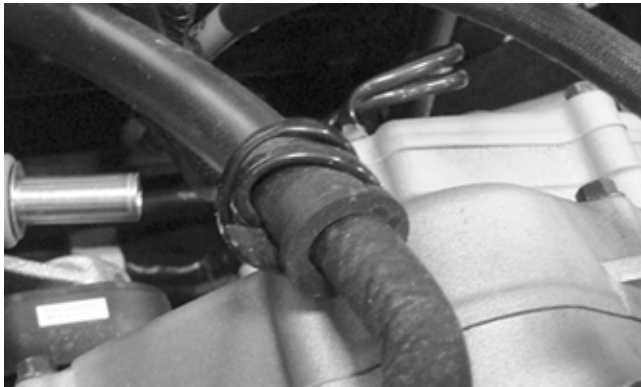

PK181

9. Place the starter cable onto the starter motor and secure it with the nut. Secure the engine ground cable to the engine using the front starter motor mount cap screw. Tighten securely.

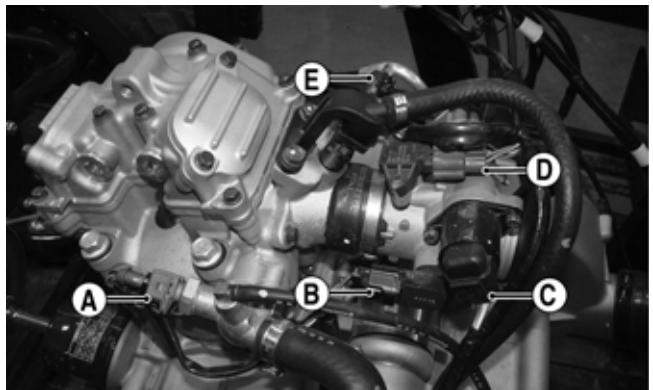

PK170A

12. Place a new exhaust gasket into the cylinder head; then install the exhaust pipe. Secure the exhaust pipe to the cylinder head studs with the two nuts. Tighten to 15 ft-lb (20.4 N-m). Using a new exhaust seal, install the muffler to the exhaust pipe and secure using the two springs. Connect the O2 sensor connector, then secure the wires to the frame using the previously marked location with a new cable tie.

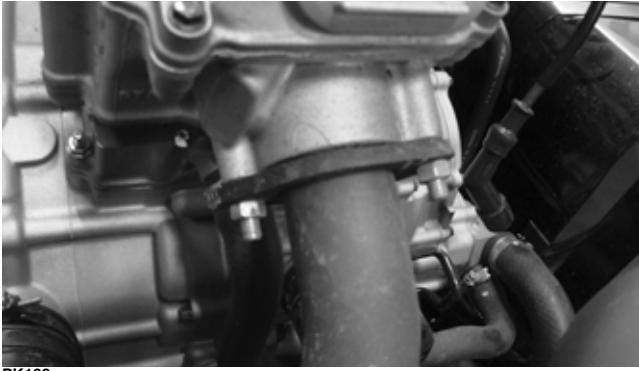

PK169



PK168

13. With the help of an assistant, place the rear ROPS and seat frame assembly back onto the frame.
14. Loosely install the cap screws securing the center of the seat frame to the main frame.

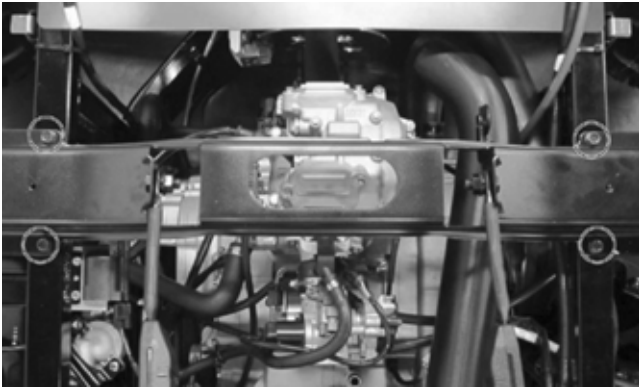

PK182

15. From each side of the vehicle, loosely install the eight cap screws securing the outside of the seat frame to the top of the main frame.

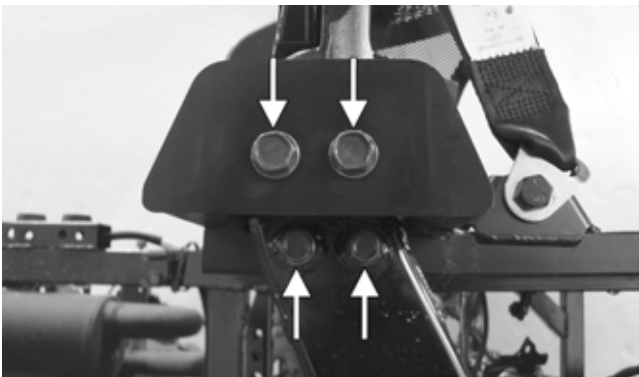

PK166A

16. Loosely install the cap screws from the front of the seat frame to the main frame.

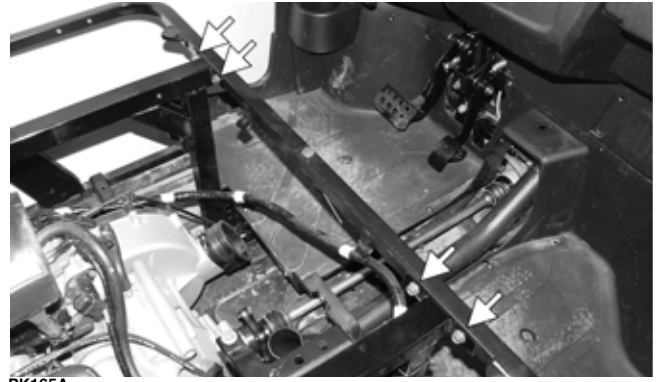

PK165A

17. Install new patch-lock cap screws and nuts securing the front and rear ROPS assemblies together. Tighten the ROPS fasteners to 47 ft-lb (63.9 N-m).



PK089

18. Tighten the cap screws from steps 14 and 16 to 22 ft-lb (29.9 N-m).
19. Tighten the cap screws from step 15 (A) to 45 ft-lb (61.2 N-m) and (B) to 22 ft-lb (29.9 N-m).

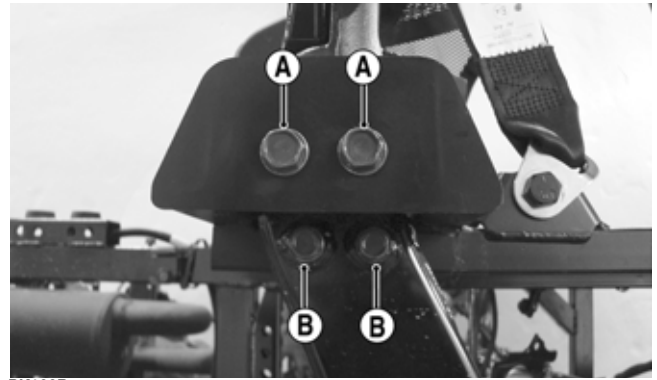

PK166B

20. Route the wiring harness along the front of the seat frame. Secure the thermostat bracket to the bottom of the seat frame. Install the rear gear case bladder to the center splash panel. Install the CVT intake and exhaust ducts. Connect and secure the driver's seat belt limiter switch connector.

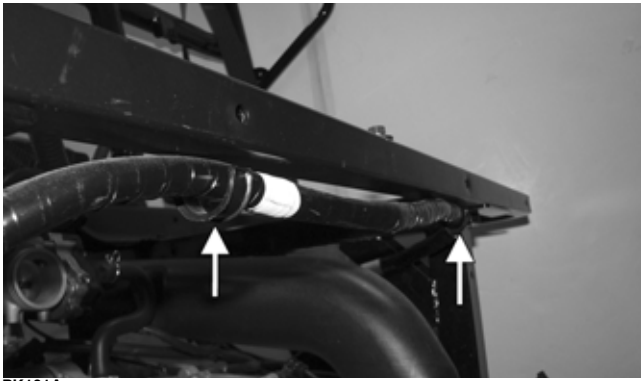

PK161A



PK162

21. Place the air box assembly into position; then secure the cap screws and clamps. Connect the crankcase breather hose to the air inlet tube.

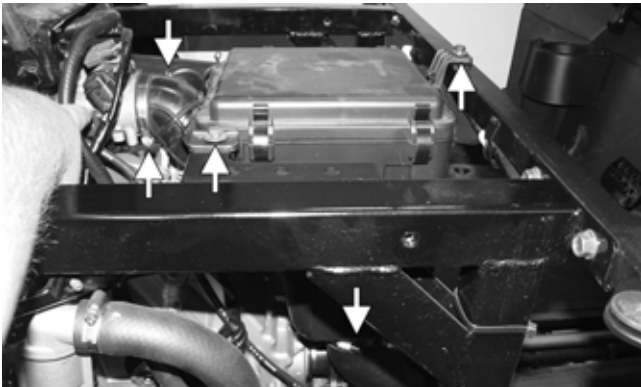

PK160A

22. Install both left and right-rear splash panels; then secure them using the reinstallable plastic rivets. Install both left and right side panel assemblies (see Dashboard).

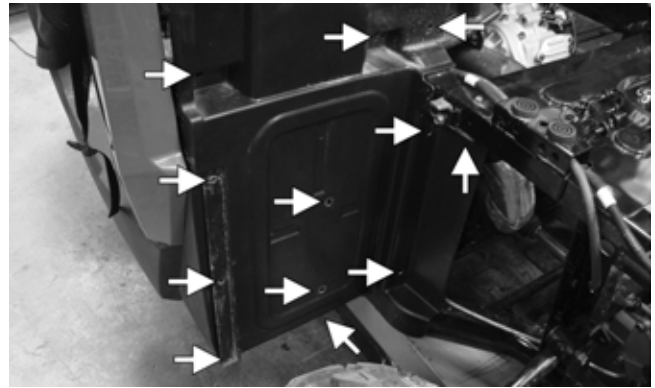

PK108A

23. Pour the recommended amount of oil and coolant into the engine and radiator.

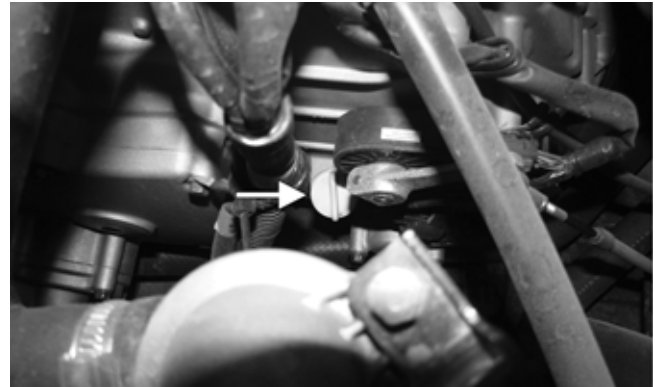

PK024A

24. Connect the negative battery cable to the battery.

25. Install the engine compartment panel and seat.

26. Start the engine and check for leaks while allowing the engine to warm up for several minutes; then shut the engine off and check engine oil and coolant levels.

Fuel/Lubrication/ Cooling

TROUBLESHOOTING

1. Verify that the electric fuel pump is operating by listening for a “whirring” sound for several seconds after the ignition switch is turned to the ON position. If no sound can be heard, see EFI Sensors/Components in Electrical System.
2. Check for a flashing EFI icon on the LCD. If EFI is flashing, see EFI Diagnostic System in Electrical System.
3. Make sure there is sufficient, clean gas in the gas tank.

SPECIAL TOOLS

A number of special tools must be available to the technician when performing service procedures in this section. Refer to the current Special Tools Catalog for the appropriate tool description.

■**NOTE:** When indicated for use, each special tool will be identified by its specific name, as shown in the chart below, and capitalized.

Description	p/n
Oil Pressure Test Kit	0644-495
Tachometer	Common Tool

■**NOTE:** Special tools are available from the Service Department.

Throttle Body

⚠ WARNING

Whenever the fuel hoses are removed (other than for pressure testing), the battery must be disconnected to prevent inadvertent activation of the electronic fuel pump.

⚠ WARNING

Whenever any maintenance or inspection is performed on the fuel system during which there may be fuel leakage, there should be no welding, smoking, open flames, etc., in the area.

REMOVING

1. Turn the ignition switch to the OFF position; then remove the ignition switch key.

⚠ WARNING

Do not turn the ignition switch to the ON position with the hoses removed. Gasoline will be pumped by the electric fuel pump causing a safety hazard.

2. Remove the seat and air box assembly.
3. Disconnect the TPS (A), ISC (B), and TMAP (C) connectors from the throttle body assembly.



PK170B

4. Remove the screws from the throttle arm cover and remove the cover. Note the different-length screws.



PK183A

⚠ WARNING

Gasoline may be under pressure. Place an absorbant towel under the connector to absorb any gasoline spray when disconnecting.

5. Loosen the clamp securing the throttle body to the intake manifold boot and remove the throttle body assembly. Note the notch in the intake manifold boot for alignment purposes.

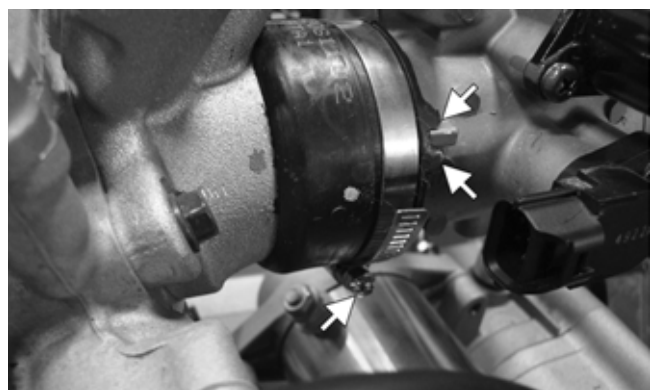

PK184A

6. Use tape to cover and seal the intake opening.

CAUTION

Any objects or liquid entering the intake opening will fall into the engine causing severe damage if the engine is turned over or started.

INSTALLING

1. Install the throttle body into the intake manifold boot and secure with the clamp. Tighten to 30 in.-lb (3.4 N-m).
2. Connect the throttle cable to the throttle body; then install the throttle arm cover and secure it to the throttle body with the two screws.
3. Connect the electrical connectors to the throttle body components.
4. Install the air filter assembly and secure with the existing hardware.
5. Install the seat.

■ **NOTE:** If the throttle body, ECM, TPS, or ISC are replaced, the EFI system must be synchronized. Use the following procedure.

1. With the key off, depress accelerator pedal to Wide Open Throttle (WOT).
2. Place the ignition key in the ON position and wait for 10 seconds.
3. Release the accelerator pedal and wait an additional 10 seconds.
4. Turn the key to the OFF position and allow the gauge to shut off.

Gas Tank

WARNING

Whenever any maintenance or inspection is made on the fuel system during which there may be fuel leakage, there should be no welding, smoking, open flames, etc., in the area.

REMOVING

1. Remove the seat, and engine compartment panel.



PK186

2. Remove the cap screw securing the passenger net restraint to the right side panel assembly; then remove the reinstallable rivet securing the right-rear splash panel to the right side panel assembly. Remove the remaining reinstallable rivets securing the right-rear splash panel; then remove the splash panel.

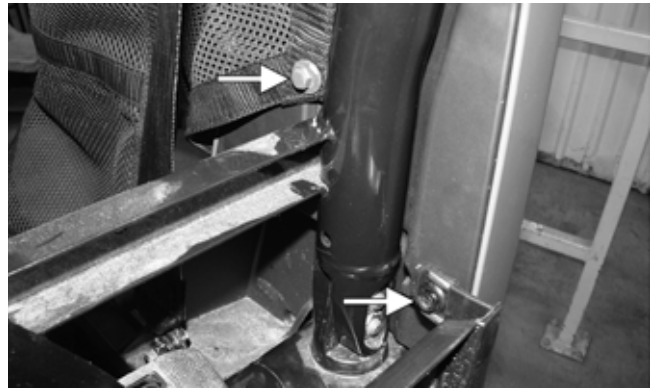

PK187A

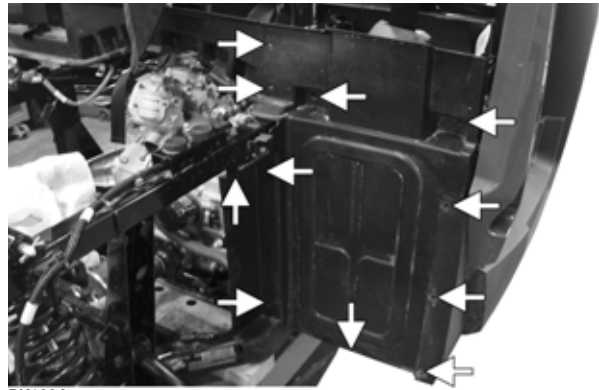

PK188A

3. Remove the gas cap from the fuel tank; then remove the cap screw and three reinstallable rivets securing the bottom of the right-side panel assembly to the skid plate.

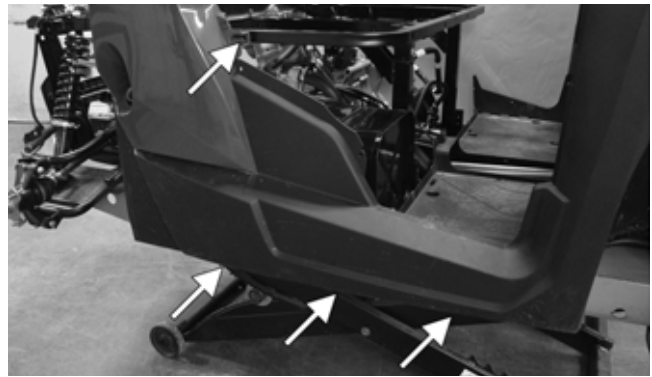

PK189A

4. Carefully pull the right side panel assembly away from the fuel tank filler neck. Use a bungee cord to support the panel. Pull the vent line out of the frame.



PK190

- Place a shop towel under the fuel line connector; then squeeze the release tab to remove. Disconnect the fuel pump harness connector.



PK191

- Remove the nuts securing the fuel tank straps to the frame and tank mount to frame. Remove the fuel tank from the rear.

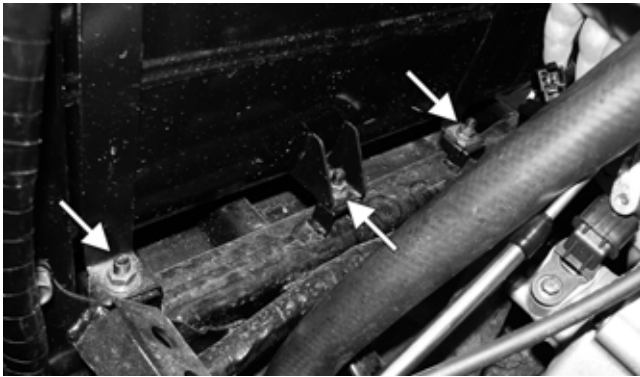

PK192A

CLEANING AND INSPECTING

- Clean all gas tank components with parts-cleaning solvent.
- Inspect all hoses for cracks or leaks.
- Inspect gas tank cap and tank for leaks, holes, and damaged threads.
- Inspect the fuel level sensor for proper operation (see EFI Sensors/Components in Electrical System).

INSTALLING

WARNING

Whenever any maintenance or inspection is made on the fuel system during which there may be fuel leakage, there should be no welding, smoking, open flames, etc., in the area.

- Place the gas tank into position in the vehicle; then secure the middle tank mount to the frame and two hold-down straps with nuts. Tighten securely.

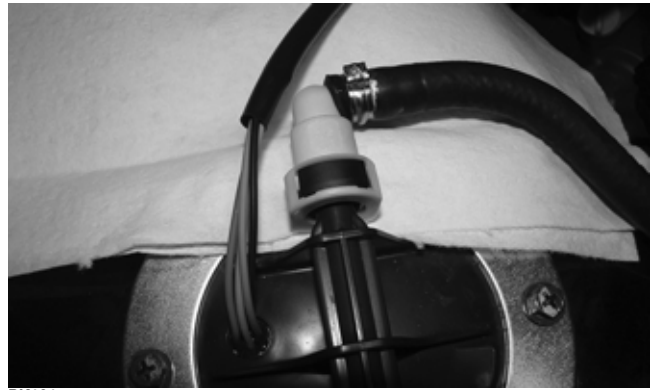

PK191

- Connect the fuel line to the fuel pump; then verify the connector is fully seated to the fuel pump juncture. Connect the fuel pump harness connector to the main wiring harness.



PK193

- Position the right-side panel assembly so the fuel tank filler neck protrudes through; then secure the side panel assembly to the frame using the three reinstallable rivets and one cap screw.

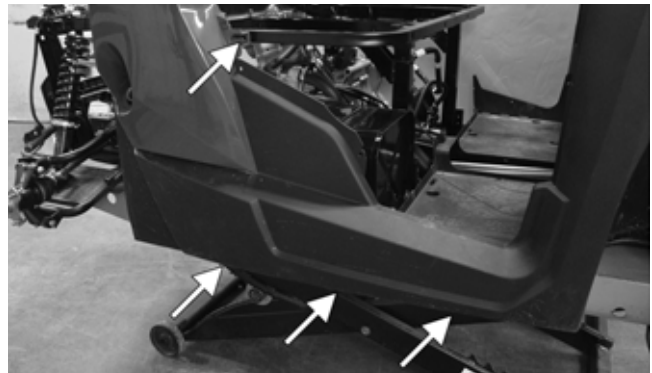

PK189A

- Install and secure the right-rear splash panel with reinstallable rivets.

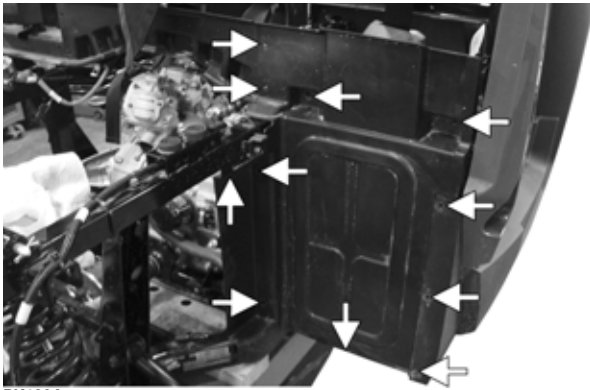

PK188A

5. Secure the passenger side under seat storage tray using four cap screws and tighten securely.

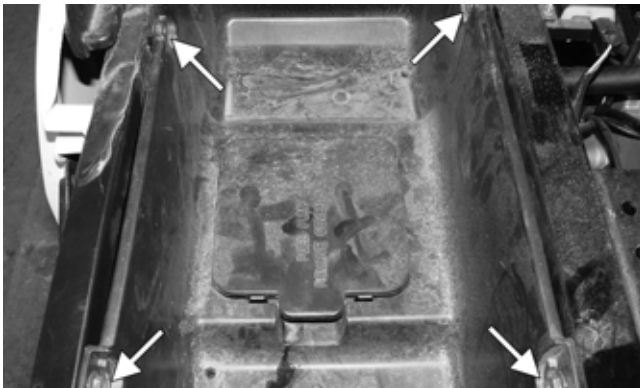

PK194A

6. Install the engine compartment panel; then secure it using the cap screws and reinstallable rivets.



PK151A

7. Install the seat.

Oil Pump

■NOTE: Whenever internal engine components wear excessively or break and whenever oil is contaminated, the oil pump should be replaced.

TESTING OIL PUMP PRESSURE

■NOTE: The engine must be warmed up to operating temperature (cooling fan cycling) for this test.

1. Remove the right-rear splash panel. Connect the Tachometer to the engine or utilize the LCD.

2. Connect the Oil Pressure Test Kit to the oil pressure test port.

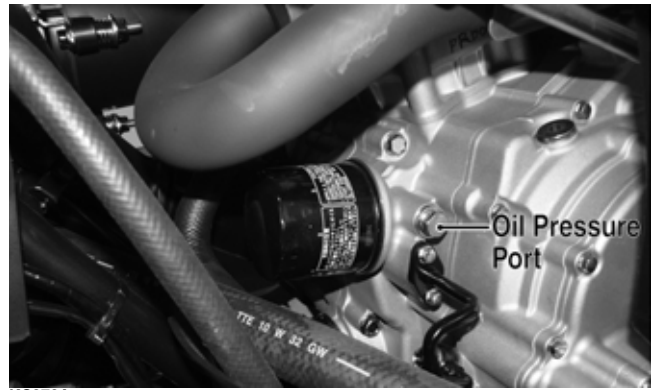

KC370A

■NOTE: Some oil seepage may occur when installing the oil pressure gauge. Wipe up oil residue with a cloth.

3. Block the wheels, place the transmission in neutral, and start the engine. Allow the engine to warm up to operating temperature (with cooling fan cycling).
4. With the engine running at 3000 RPM, the pressure gauge must show 1.12-1.47 kg/cm² (16-21 psi).
5. Remove the test kit and tachometer from the vehicle and install the oil pressure port plug. Tighten securely.
6. Install the right-rear splash panel.

■NOTE: If the oil pressure is lower than specified, check for an oil leak, damaged oil seal, or defective oil pump.

■NOTE: If the oil pressure is higher than specified, check for too heavy engine oil weight (see General Information/Foreword, Gasoline — Oil — Lubricant), clogged oil passage, clogged oil filter, or improper installation of the oil filter.

REMOVING/DISASSEMBLING

Remove the oil pump from the engine (see Left-Side Components in the Engine/Transmission section).

INSPECTING

1. Inspect the pump for damage.
2. It is inadvisable to remove the screw securing the pump halves together. If the oil pump is damaged, it must be replaced.

■NOTE: The oil pump is only serviceable as an assembly.

ASSEMBLING/INSTALLING

Install the oil pump (see Installing Left-Side Components in the Engine/Transmission section).

Liquid Cooling System

When filling the cooling system, use premixed anti-freeze. Verify the coolant level in the reservoir tank is between the FULL and LOW indicator lines. Fill as needed. While the main cooling system is being filled, air pockets may develop. Fill the cooling system to the bottom of the stand pipe in the radiator neck. Run the engine for 3 minutes to allow air to bleed from the cooling system. After the initial fill, shut the engine off, and then “top-off” the cooling system to the bottom of the stand pipe in the radiator neck. Install the radiator cap.

■NOTE: Use a good quality, biodegradable glycol-based, automotive-type antifreeze. When filling the cooling system, use a 60/40 coolant/water mixture or one which will satisfy the coldest anticipated weather conditions of the area in accordance with the coolant manufacturer’s recommendations.

⚠ WARNING

Never check the coolant level when the engine is hot or the cooling system is under pressure.

CAUTION

After operating the vehicle for the initial 5-10 minutes, stop the engine, allow the engine to cool down, and check the coolant level. Add coolant as necessary.

COOLING SYSTEM PRESSURE TESTING

1. Remove the front hood and radiator access panel. Use a readily available pressure tester. Wet the pressure tester seal; then connect the pressure tester to the radiator filler neck.
2. Pump the tester up to 12.8 psi (0.9 kg/cm²). The coolant system should hold this pressure for up to 6 seconds. If it does not, inspect the entire coolant system for leaks. Do not exceed 14.9 psi (1.05 kg/cm²) when pressure testing the coolant system.
3. To test the radiator cap relief pressure, wet the seal on the cap. Connect the tester to the radiator cap. The relief pressure specification for the cap is 12.8 psi (0.9 kg/cm²). If the cap does not relieve pressure as specified, replace the cap.

RADIATOR

Removing

1. With the vehicle on a flat level surface, set the transmission into the Park position then chock the wheels. Remove the center and right-side skid plates. Remove the front hood and radiator access panel.



PK084

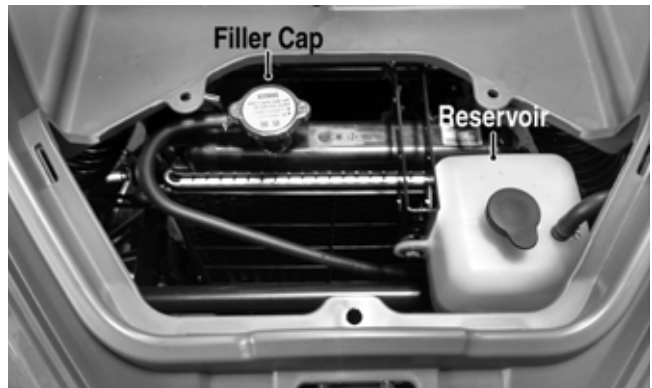

PK074A

2. Remove the radiator cap; then drain the coolant into a suitable container by removing the drain plug found on the water pump. Account for the washer. Disconnect the cooling fan wire connector from the main harness.

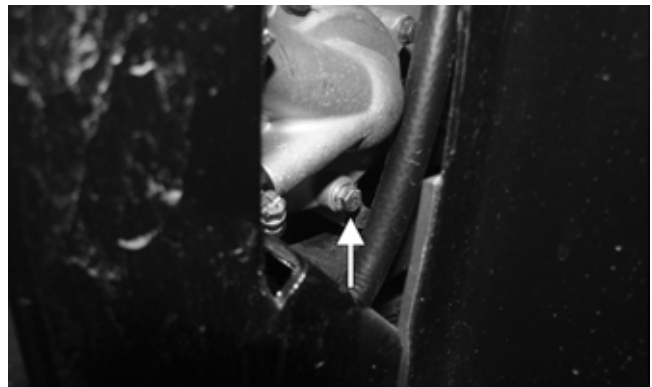

PK196A



PK197

3. Remove the lower fascia (see Front Fascia/Front Bumper section).

- Loosen the clamps; then remove the upper and lower main coolant hoses from the radiator. Remove the reservoir hose (B) from the right side of the filler neck and the bleed hose (A) from the back of the filler neck.

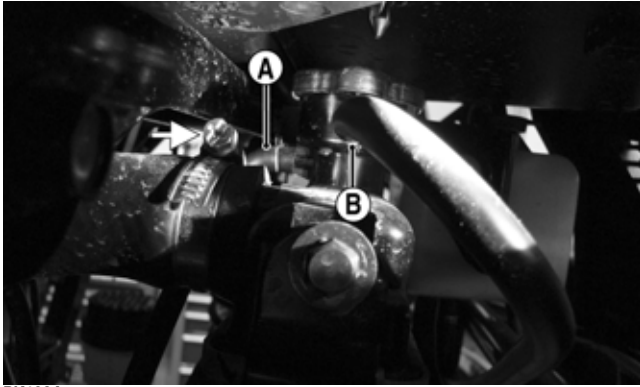

PK198A

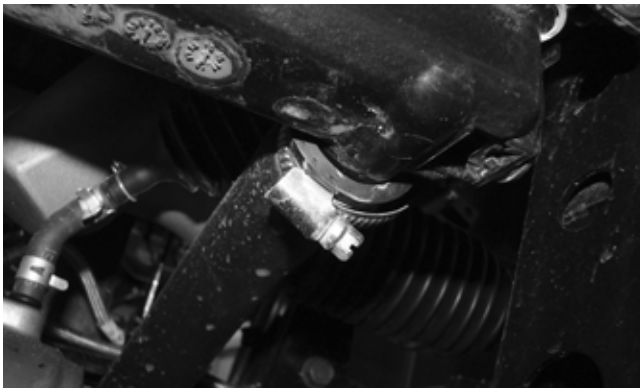

PK199

- Remove the two cap screws securing the upper section of the radiator bracket to the frame; then remove the lower cap screws securing the bracket to the frame.



PK200



PK201A

- Lower the radiator through the front bumper. Account for two upper and two lower rubber mounting grommets.

■ **NOTE:** Removal of the radiator fan does not require removal of the radiator (see COOLING FAN).

Cleaning and Inspecting

- Flush internal coolant passage ways of the radiator with distilled water to remove any contaminants. Flush the external air passage ways with tap water to clear any debris from the cooling fins. Do not use a pressure washer to clear debris from the cooling fins.
- Inspect the radiator for leaks and damage.
- Inspect all hoses for cracks and deterioration.
- Inspect all fasteners and grommets for damage or wear.

Installing

- Place the radiator into position making sure the grommets are correctly installed; then secure to the mounts with the four cap screws and nuts. Tighten to 8 ft-lb (10.9 N-m). Install the lower fascia.



PK200

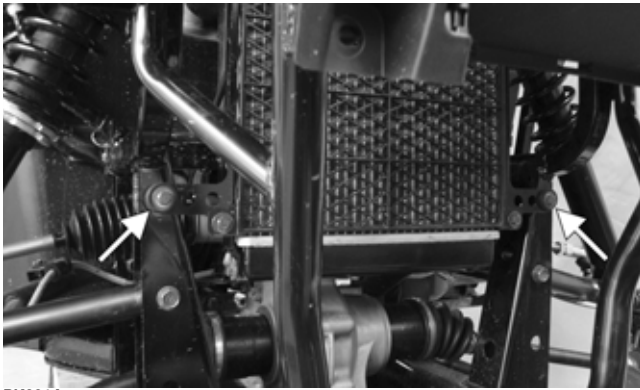

PK201A

2. Connect the upper and lower coolant hoses to the radiator and secure with the appropriate hose clamps; then connect the cooling fan wire connector to the main harness. Connect the reservoir hose (B) to the right side of the filler neck and the bleed hose (A) to the back side of the radiator filler neck.

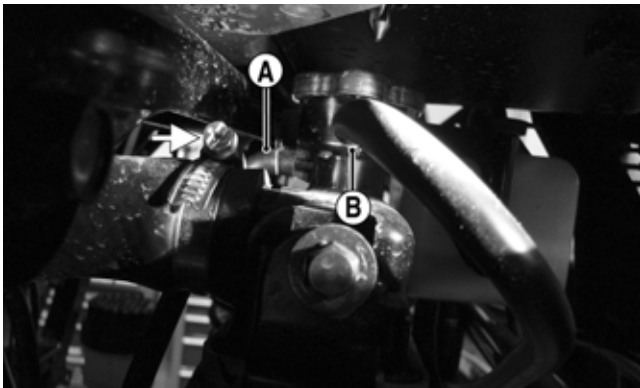

PK198A



PK197

3. Pour the recommended coolant into the radiator and reservoir tank. Bleed the cooling system (see Liquid Cooling System).
4. Start the engine and warm up to operating temperature. Allow the engine to completely cool to room temperature; then verify the coolant level is at the bottom of the stand pipe in the radiator neck. Check coolant level in reservoir tank. Add coolant as necessary.
5. Install both skid plates, radiator access panel, and front hood.

THERMOSTAT

Removing

1. Drain approximately one quart of coolant from the cooling system.
2. Remove the two cap screws securing the thermostat housing to the bracket. Account for a thermostat with seal and O-ring installed in the thermostat housing cover.

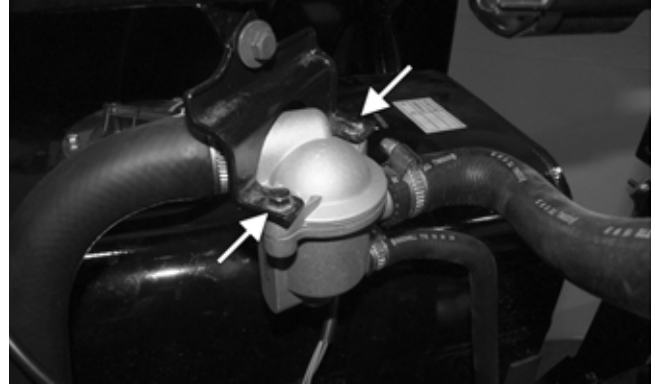

PK202A.

Inspecting

1. Inspect the thermostat for corrosion, wear, or spring damage.
2. Using the following procedure, inspect the thermostat for proper operation:
 - A. Suspend the thermostat in a container filled with water. Do not allow the thermostat to contact the container.
 - B. Heat the water and monitor the temperature with a thermometer.
 - C. The thermostat should start to open at 176-183°F (80-84°C) and be fully open at 203°F (95°C). Minimum valve lift is approximately 8 mm (0.03 in).
 - D. If the thermostat does not open, it must be replaced. If the thermostat does not close at room temperature, it must be replaced.
3. Inspect all coolant hoses, connections, and clamps for deterioration, cracks, and wear.

■NOTE: All coolant hoses and clamps should be replaced every four years or 4000 miles (6400 km).

Installing

1. Place the thermostat into the housing; then lightly grease the O-ring in the housing cover. Place the cover onto the thermostat housing; then secure the assembly to the bracket. Secure the cap screws.



PK203

2. Fill the cooling system with the recommended amount of antifreeze. Check for leakage.

COOLING FAN

Removing

1. Disconnect the fan connector from the main harness.
2. Remove the bleed hose from the routing clamp (A). Remove the four nuts (B) securing the fan to the radiator bracket; then remove the fan from the radiator.

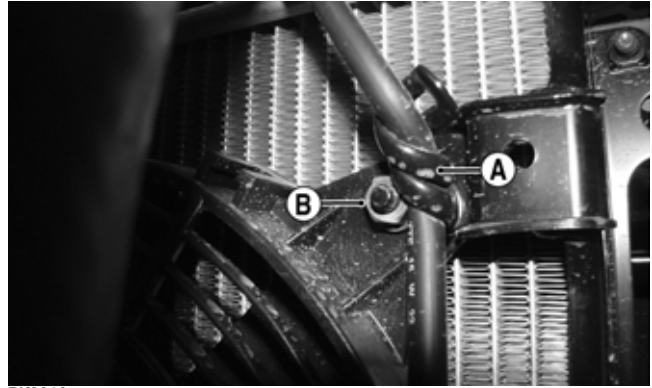

PK204A

Installing

1. Position the fan assembly on the radiator bracket; then secure with existing hardware.

■NOTE: Secure the radiator bleed hose using the routing clamp located toward the top right side of the fan assembly.

2. Secure the fan connector to the main harness.

WATER PUMP

■NOTE: To service the water pump, see Servicing Right-Side Components.

Troubleshooting

Problem: Starting impaired	
Condition	Remedy
1. Gas contaminated	1. Drain gas tank and fill with clean gas
Problem: Idling or low speed impaired	
Condition	Remedy
1. TPS out of adjustment	1. Adjust TPS
Problem: Medium or high speed impaired	
Condition	Remedy
1. High RPM "cut out" against RPM limiter	1. Decrease RPM speed

Electrical System

The electrical connections should be checked periodically for proper function.

TESTING ELECTRICAL COMPONENTS

All electrical tests should be made using the Dealer Diagnostic Service or the Fluke Model 88 Multimeter. The Dealer Diagnostic Service can return data for certain components which are identified at the beginning of their respective sub-section. If any other type of meter is used, readings may vary due to internal circuitry. When troubleshooting a specific component, always verify first that the fuse(s) are good, that the instrument gauge is properly functioning, that the connections are clean and tight, that the battery is fully charged, (with a minimum cranking voltage of approximately 10.8 VDC at the battery), and that all appropriate switches are activated.

■NOTE: For absolute accuracy, all tests should be made at room temperature of 68° F (20° C).

■NOTE: Certain components and sensors can be checked by using the EFI diagnostic system (see EFI Diagnostic System in this section for more information).

SPECIAL TOOLS

A number of special tools must be available to the technician when performing service procedures in this section. Refer to the current Special Tools Catalog for the appropriate tool description.

■NOTE: When indicated for use, each special tool will be identified by its specific name, as shown in the chart below, and capitalized.

Description	p/n
Fluke Model 88 Multimeter	Common Tool
Dealer Diagnostic Service	0544-034
MaxiClips	Common Tool
Timing Light	Common Tool
Ignition Test Plug	Common Tool

■NOTE: Special tools are available from the Service Department.

Battery

Component data can be retrieved using the Dealer Diagnostic Service. Utilize the Sensor Data screen.

■NOTE: Preliminary checks may be performed on this component using the diagnostic mode on the LCD gauge (see EFI Diagnostic System in this section).

The battery is located under the seat on the driver's side.

After being in service, batteries require regular cleaning and recharging in order to deliver peak performance and maximum service life. The following procedures are recommended for cleaning and maintaining lead-acid batteries. Always read and follow instructions provided with battery chargers and battery products.

■NOTE: Refer to all warnings and cautions provided with the battery or battery maintainer/charger.

Loss of battery charge may be caused by ambient temperature, ignition OFF current draw, corroded terminals, self discharge, frequent start/stops, and short engine run times. Frequent winch usage, snowplowing, extended low RPM operation, short trips, and high amperage accessory usage are also reasons for battery discharge.

Maintenance Charging

■NOTE: The manufacturer recommends the use of the CTEK Multi US 800 or the CTEK Multi US 3300 for battery maintenance charging. Maintenance charging is required on all batteries not used for more than two weeks or as required by battery drain.

1. When charging a battery in the vehicle, be sure the ignition switch is in the OFF position.

■NOTE: Be sure to maintain the fluid of the battery at the UPPER LEVEL. Use only distilled water when adding fluid to these batteries.

2. Clean the battery terminals with a solution of baking soda and water.
3. Be sure the charger and battery are in a well-ventilated area and ensure the battery charger cables will not contact any battery acid. Be sure the charger is unplugged from the 110-volt electrical outlet.
4. Connect the red terminal lead from the charger to the positive terminal of the battery; then connect the black terminal lead of the charger to the negative terminal of the battery.
5. Plug the battery charger into a 110-volt electrical outlet.
6. If using the CTEK Multi US 800, there are no further buttons to push. If using the CTEK Multi US 3300, press the Mode button (A) at the left of the charger until the Maintenance Charge Icon (B) at the bottom illuminates. The Normal Charge Indicator (C) should illuminate on the upper portion of the battery charger.



800A

■NOTE: The maintainer/charger will charge the battery to 95% capacity at which time the Maintenance Charge Indicator (D) will illuminate and the maintainer/charger will change to pulse/float maintenance. If the battery falls below 12.9 DC volts, the charger will automatically start again at the first step of the charge sequence.

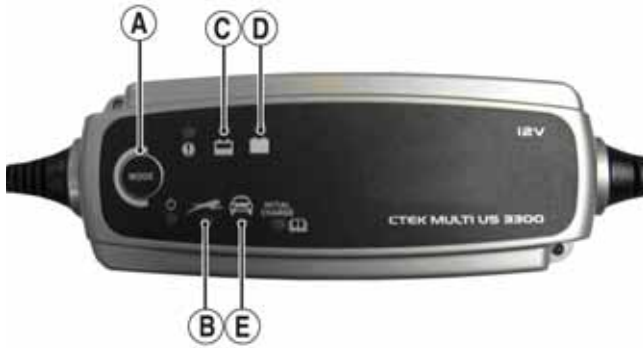

3300C

■NOTE: Not using a battery charger with the proper float maintenance will damage the battery if connected over extended periods.

Charging

■NOTE: The manufacturer recommends the use of the CTEK Multi US 800 or the CTEK Multi US 3300 for battery maintenance charging.

1. Be sure the battery and terminals have been cleaned with a baking soda and water solution.
2. Be sure the charger and battery are in a well-ventilated area and ensure the battery charger cables will not contact any battery acid. Be sure the charger is unplugged from the 110-volt electrical outlet.
3. Connect the red terminal lead from the charger to the positive terminal of the battery; then connect the black terminal lead of the charger to the negative terminal of the battery.
4. Plug the charger into a 110-volt electrical outlet.
5. By pushing the Mode button (A) on the left side of the charger, select the Normal Charge Icon (E). The Normal Charge Indicator (C) should illuminate on the upper left portion of the charger.
6. The battery will charge to 95% of its capacity at which time the Maintenance Charge Indicator (D) will illuminate.

■NOTE: For optimal charge and performance, leave the charger connected to the battery for a minimum 1 hour after the Maintenance Charge Indicator (D) illuminates. If the battery becomes hot to the touch, stop charging. Resume after it has cooled.

7. Once the battery has reached full charge, unplug the charger from the 110-volt electrical outlet.

■NOTE: If, after charging, the battery does not perform to operator expectations, bring the battery to an authorized dealer for further troubleshooting.

Ignition Switch

The ignition switch connector can be accessed by removing the front left splash panel.

VOLTAGE

■NOTE: Perform this test on the harness connector.

1. Set the meter selector to the DC Voltage position.
2. Connect the red meter lead to the red wire; then connect the black meter lead to battery ground.
3. Meter must show battery voltage.

■NOTE: If the meter shows no battery voltage, troubleshoot the main 30-amp fuse (PDM), the battery, or the main wiring harness.

4. With the switch connected to the harness, connect the red meter lead to the red/black wire and the black meter lead to ground; then turn the ignition switch to the ON position. The meter must show battery voltage.
5. Connect the red meter lead to the yellow/green wire; then with the black meter lead grounded, turn the ignition switch to the START position. The starter should engage and the meter must show battery voltage.

■NOTE: When the starter is engaged, battery voltage will be approximately 10.8 DC volts.

Ignition Coil

The ignition coil is mounted under the seat below the passenger's side.

VOLTAGE

Primary Coil

1. Set the meter selector to the DC Voltage position; then disconnect the primary connector from the ignition coil.
2. Connect the red tester lead to the orange wire and the black tester lead to ground.
3. Turn the ignition switch to the ON position. The meter must show battery voltage.

Secondary Coil

CAUTION

Disconnect the injector connector before performing the following procedure.

1. Connect the primary ignition coil connector. Remove the spark plug cap from the spark plug.
2. Connect the spark plug cap to Ignition Test Plug or other suitable tool; then ground the tool away from the spark plug hole. While turning the engine over, check for sufficient spark.

RESISTANCE

CAUTION

Always disconnect the battery when performing resistance tests to avoid damaging the multimeter.

■NOTE: For these tests, the meter selector should be set to the OHMS position.

Primary Winding

1. Connect the red tester lead to one terminal; then connect the black tester lead to the other terminal.



HDX290

2. The meter reading must be less than 1 ohm.

SECONDARY WINDING

1. Remove the spark plug cap from the spark plug wire. Disconnect the primary connector from the ignition coil.
2. With the meter set to OHMS, connect the red meter lead to the spark plug wire and the black meter lead to either primary side terminal of the ignition coil. The meter should read approximately 25 mega ohms.

Spark Plug Cap

1. Connect the red tester lead to one end of the cap; then connect the black tester lead to the other end of the cap.

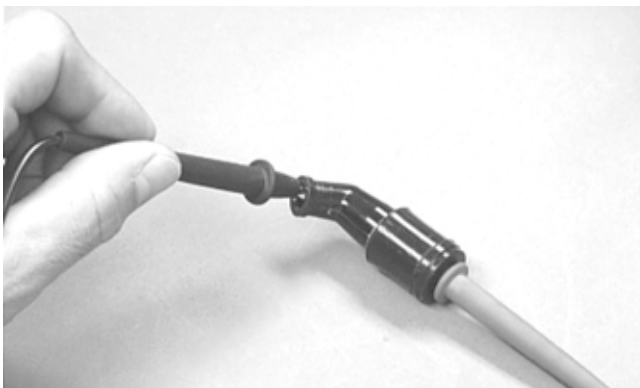

AR603D

2. The meter must show 4000-6000 ohms.

■NOTE: If the meter does not show as specified, replace the spark plug cap.

Ignition Timing

The ignition timing cannot be adjusted; however, verifying ignition timing can aid in troubleshooting other components. To verify ignition timing, use the following procedure:

■NOTE: To check ignition timing, the seat, seat back, and seat base must be removed.

1. Attach the Timing Light to the spark plug high tension lead; then remove the timing inspection plug from the right-side crankcase cover.
2. Start the engine and using the RPM function on the speedometer/tachometer, run at 1425 RPM; ignition timing should be 12° BTDC.
3. Install the timing inspection plug.

If ignition timing cannot be verified, the rotor may be damaged, the key may be sheared, the trigger coil bracket may be bent or damaged, or the ECM may be faulty.

Accessory Connector

■NOTE: This test procedure is for either switched accessory connector. One is found under the seat and the other can be accessed by removing the front right splash panel.

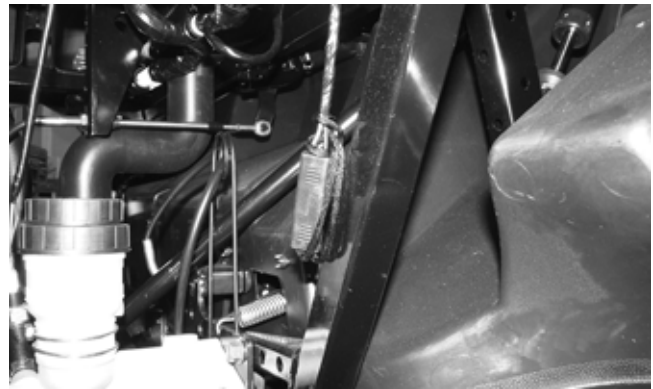

PK067

VOLTAGE

1. Turn the ignition switch to the ON position; then set the meter selector to the DC Voltage position.
2. Connect the red tester lead to the orange/black wire; then connect the black tester lead to ground.
3. With the key in the ON position, the meter must show battery voltage.

■NOTE: The dash mounted receptacle and right-rear mounted accessory connector are continuously supplied with 12 VDC.

■NOTE: If the meter shows no battery voltage, troubleshoot the battery, fuses, receptacle, connector, or the main wiring harness.

Switches

SEAT BELT LIMITER SWITCH

1. Remove the passenger seat. Locate the switch connector on the driver's side; then disconnect.
2. Buckle the driver's seat belt. On the switch side, connect one meter lead to one pin and the other meter lead to the opposite connector pin.



HDX374

3. The meter should read less than one ohm.
4. Release the seat belt latch from the buckle while the meter leads are connected to the pins. Meter reading should show OFL.

■NOTE: If the meter readings are OFL or greater than one ohm with the seat belt buckled, replace the buckle switch assembly. If the resulting readings from step 4 are not OFL, replace the buckle switch assembly.

VOLTAGE (Taillight)

■NOTE: The ignition switch must be in the ON position.

1. Set the meter to the DC Voltage position. Disconnect the connector from the back of the taillight assembly.
2. Connect the red tester lead to the white/red wire and the black tester lead to the black wire.
3. With the headlight switch in the running, low and high beam positions, the meter should read approximately battery voltage.

■NOTE: If the meter shows no battery voltage, troubleshoot the main wiring harness, 10-amp LIGHTS fuse, headlight switch or the battery.

■NOTE: If the meter shows battery voltage, the main wiring harness and related components are good; proceed to checking the bulb.

VOLTAGE (Brake Light)

Component data can be retrieved using the Dealer Diagnostic Service. Utilize the Sensor Data screen.

■NOTE: The ignition switch must be in the ON position.

1. Set the meter selector to the DC Voltage position. Disconnect the connector from the back of the taillight assembly.
2. Connect the red tester lead to the red/blue wire and black tester lead to the black wire.



PK328

3. Depress and hold the brake pedal. The meter must show battery voltage.

■NOTE: If the meter shows no battery voltage, troubleshoot the main wiring harness, switch, fuse or the battery.

■NOTE: If the meter shows battery voltage, the main wiring harness and related components are good. Proceed to check the bulb.

RESISTANCE (Brake Light)

CAUTION

Always disconnect the battery when performing resistance tests to avoid damaging the multimeter.

■NOTE: The brake pedal must be depressed for this test.

1. Set the meter selector to the OHMS position. Remove both wires from the switch.
2. Connect the red tester lead to one terminal spade; then connect the black tester lead to the other terminal spade.

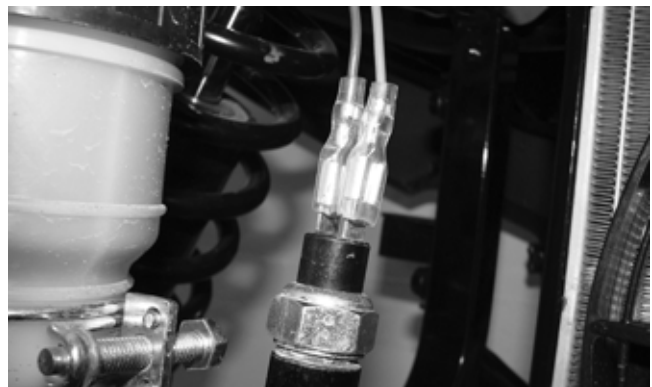

PK292

- When the lever is depressed, the meter must read continuity. When released, the meter must read show OFL.

■NOTE: If the meter readings are not as described, replace the switch.

VOLTAGE (Headlight)

- Connect the red meter lead to the white wire; then connect the black meter lead to the black wire.
- Turn the ignition switch to the ON position and the headlight switch to the low-beam position (C). The meter must show battery voltage.

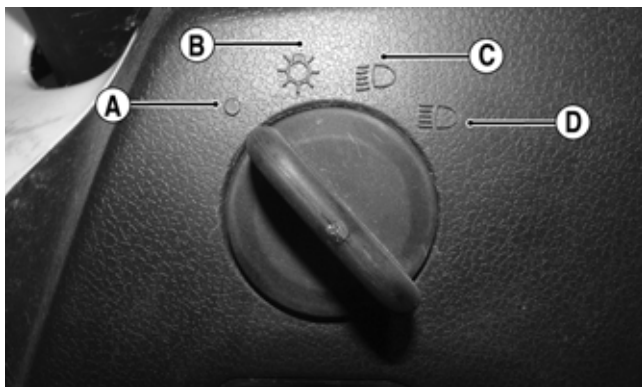

PK021A

■NOTE: If the meter does not show battery voltage, troubleshoot the 10-amp LO-BEAM fuse on the power distribution module, the headlight switch, main relay, 30-amp MAIN fuse, 10-amp LIGHTS fuse or the main harness.

- Connect the red meter lead to the yellow/black wire; then select the high beam (D) position on the headlight switch. The meter must show battery voltage.

■NOTE: The battery voltage will show lower in steps 2 and 3 due to electrical loading of the headlights.

RESISTANCE (Drive Select)

Component data can be retrieved using the Dealer Diagnostic Service. Utilize the Sensor Data screen.

- Remove the instrument gauge from the switch panel; then remove the four cap screws securing the switch panel to the dashboard. Disconnect the switches.
- Using an ohmmeter, the following readings must be observed:

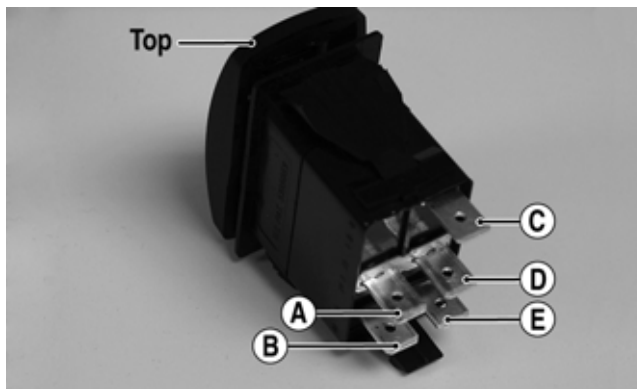

PR566A

2WD	4WD	DIFFERENTIAL LOCK
A to D <1 ohm	A to D <1 ohm	A to D <1 ohm
C to E 51 ohms	C to E 51 ohms	C to E 51 ohms
A to B Open	A to B <1 ohm	A to B <1 ohm
A to C Open	A to C Open	A to C 51 ohms
A to E Open	A to E Open	A to C <1 ohm

VOLTAGE (Drive Select)

■NOTE: Voltage tests must be made with the switch and the actuator connected. The meter leads can be connected at the back of the drive select switch using a break-out harness or MaxiClips. The front drive actuator connector must be connected. The connector can be accessed by removing the front skid plate.

- Connect the black tester lead to the black wire; then turn the ignition switch to the ON position.
- Select the DC Volts position on the tester and observe the meter readings for each of the three switch positions. BV represents approximately battery voltage.

WIRE COLOR	2WD	4WD	DIFFERENTIAL LOCK
Red to Orange	12.0 DC Volts	12.0 DC Volts	12.0 DC Volts
Red to White/ Green	11.5 DC Volts	0 DC Volts	0 DC Volts
Red to White/ Orange	11.5 DC Volts	11.5 DC Volts	0 DC Volts

■NOTE: If the meter does not show voltages according to the chart, make sure the front drive actuator is plugged in; then troubleshoot the switch, 10-amp power fuse, main relay, main fuse, battery connections, or wiring harness.

VOLTAGE (Reverse Override)

■NOTE: To perform the following tests, the ignition switch must be in the ON position and the transmission shifted into reverse gear.

- Remove the dash mounted switch panel. Connect the red meter lead to the red/green wire and the black meter lead to the black wire; then select 2WD on the drive select switch. The meter must show battery voltage.
- Depress the reverse override switch. The meter must show near zero volts.
- Select 4WD on the drive select switch. The meter must show battery voltage.

- Depress the reverse override switch. The meter must show near zero volts.
- Select "LOCK" on the drive select switch. The meter must show battery voltage.
- Depress the reverse override switch. The meter must show near zero volts.

■NOTE: If the voltage readings are correct and a momentary "whirring" sound is not heard from the front drive actuator, check voltage at the actuator connector. If voltage readings are correct and the actuator doesn't operate, the actuator must be replaced.

Fan Motor

This component can be tested using the Dealer Diagnostic Service. Utilize the Test screen.

■NOTE: Preliminary checks may be performed on this component using the diagnostic mode on the LCD gauge (see EFI Diagnostic System in this section).

■NOTE: To determine if the fan motor is good, disconnect the fan connector; then connect the blue wire from the fan connector to the positive side of a 12-volt battery of similar output as the vehicle. Connect the black wire from the fan connector to the negative side. The fan should operate.



PK296

WARNING

Care should be taken to keep clear of the fan blades.

■NOTE: Fan motor resistance checks are not recommended. Resistance values change with the motor commutator position.

Power Distribution Module (PDM)

■NOTE: The module and wiring harness are only serviceable as assemblies.

If there is any type of electrical system failure, always check the fuses first.

■NOTE: The fuses are located in a power distribution module under the hood.

■NOTE: Make sure the fuses are returned to their proper position according to amperage. Refer to the amperage listed under each fuse on the power distribution module.

- Remove the cover from the power distribution module.

■NOTE: To remove a fuse, compress the locking tabs on either side of the fuse case and lift out.

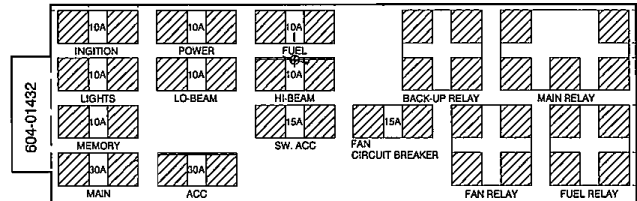

UTV-253

CAUTION

Always replace a blown fuse with a fuse of the same type and rating.

- Set the meter selector to the DC Voltage position.
- Connect the black tester lead to battery ground.
- Using the red tester lead, contact the top of each side of each fuse.



PK293

- The meter must show battery voltage from both sides of each fuse.

■NOTE: When testing the high beam, the headlight switch must be in the high-beam position. When testing the low beam, the headlight switch must be in the low-beam position.

■NOTE: If battery voltage is not indicated on both sides of each fuse, check the fuse, PDM, switches, or battery, or troubleshoot the wiring harness.

RELAYS

The 4-pin relays are identical plug-in type located on the power distribution module. Relay function can be checked by switching relay positions. The 4-pin relays are interchangeable.

PDM Relay Testing

- With the ignition switch in the OFF position, remove the suspected relay from the PDM.

- Set the meter to the OHMS position. To test the primary side of the relay, connect the meter leads to the number 85 and 86 pins. The meter will read approximately 135 ohms (4-pin relay) or 103 ohms (5-pin relay).

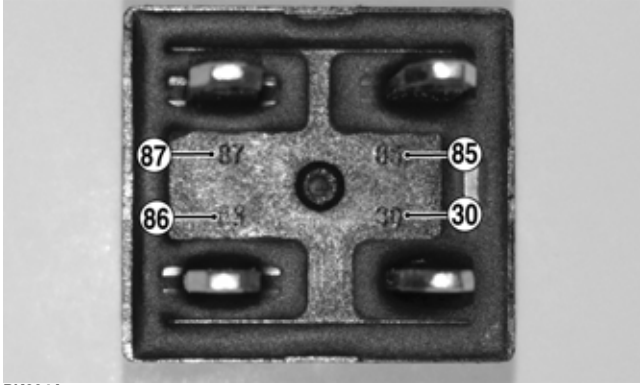

PK294A

- Testing Secondary: Using a 9-volt battery, energize the primary side pins 85 and 86; then test the resistance of the secondary side on the number 87 and 30 pins. The meter should read less than one ohm.

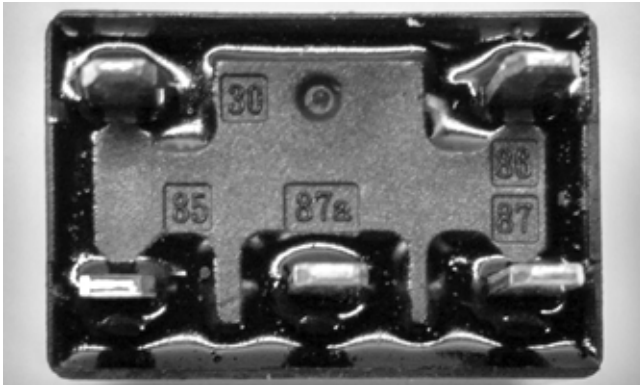

PK295

EFI Sensors/Components

FUEL INJECTOR

Component data can be tested using the Dealer Diagnostic Service. Utilize the Test screen.

Voltage

Remove the connector from the fuel injector. Place the red meter lead to the orange wire and black meter lead to ground. With the ignition switch in the on position the meter must read battery voltage. Place the red meter lead to the blue wire. The meter must read approximately 4.5 VDC.

Resistance

With the connector still removed from the injector, place the red meter lead to either terminal of the injector; then connect the black tester lead to the other terminal. Reading is typically 10.6-15.9 ohms.

■NOTE: If voltage is not present, troubleshoot the battery, connector pins, wiring harness, power fuse, the main relay, or main fuse. If resistance is not present or highly out of specification, replace the injector.

CRANKSHAFT POSITION (CKP) SENSOR

Resistance

- Set the meter selector to the OHMS position. Disconnect the connector located on the right side of the engine.
- Connect the red tester lead to the brown wire; then connect the black tester lead to the white wire. The meter reading must be 96-144 ohms.

AC Voltage

■NOTE: The battery must be at full charge for these tests.

- Set the meter selector to the AC Voltage position. Disconnect the CKP sensor.
- On the sensor side of the harness, connect the red tester lead to the brown wire; then connect the black tester lead to the white wire.
- Crank the engine over using the electric starter.
- The meter reading must be 2.0 volts or more.

OXYGEN (O2) SENSOR

Component data can be retrieved using the Dealer Diagnostic Service. Utilize the Sensor Data screen.

The Oxygen Sensor (O2 Sensor) is located in the exhaust pipe.

■NOTE: When testing the resistance of the sensor's heater, the engine/exhaust pipe must be at room temperature (65-75° F/ 18-24° C) or inaccurate readings will occur.

- Open the cargo box.
- Disconnect the sensor.



PK297

■NOTE: For this test, the meter must be in OHMS position.

- On the sensor side of connector, connect the black test lead to one white wire pin; then connect the red test lead to the other white wire pin. Readings should be between 6.7 and 10.1 ohms.

■NOTE: If the meter does not read as specified, replace the sensor.

4. Connect the black test lead to battery ground; then, on the harness side of the connector, place the red test lead to the black/green wire. With the meter set to Ohms, it should show approximately less than one ohm with the ignition switch in the OFF position.
5. With the meter set to VDC, connect the red test lead to the light blue/black wire on the harness side of the connector. With the ignition switch in the ON position, the meter will show approximately 3.2 VDC.
6. With the meter still set to VDC and the ignition switch in the ON position, set the red test lead to the light green/white wire. The meter will read approximately 4.5 VDC.
7. Finally, set the red test lead to the orange wire, the meter will read approximately battery voltage.

■NOTE: If any test results from steps 5, 6, 7, or 8 are incorrect. Troubleshoot the connectors, wiring harness, or battery.

TEMPERATURE/MANIFOLD ABSOLUTE PRESSURE (TMAP) SENSOR

Component data can be retrieved using the Dealer Diagnostic Service. Utilize the Sensor Data screen.

■NOTE: Preliminary checks may be performed on this component using the diagnostic mode on the LCD gauge (see EFI Diagnostic System in this section).

1. Disconnect the connector from the sensor located on top of the throttle body.
2. Select DC Voltage on the tester and turn the ignition switch to the ON position.
3. Connect the black tester lead to the pink/black wire and the red tester lead to the orange/blue wire. The meter should read 4.5-5.5 DC volts. If the meter does not read as specified, check the ECM connector or wiring.
4. Connect the sensor to the harness; then using Maxi-Clips, connect the red tester lead to the brown/white wire and the black tester lead to the pink/black wire. With the engine running at idle speed, the meter should read approximately 2.5 DC volts (MAP sensor signal).
5. Connect the red tester lead to the green/red wire. The meter should read approximately 2.9 DC volts.

■NOTE: If the meter does not read as specified, replace the sensor.

ENGINE COOLANT TEMPERATURE (ECT) SENSOR

Component data can be retrieved using the Dealer Diagnostic Service. Utilize the Sensor Data screen.

■NOTE: Preliminary checks may be performed on this component using the diagnostic mode on the LCD gauge (see EFI Diagnostic System in this section).

1. Connect the meter leads (selector in OHMS position) to the sensor terminals.
2. Suspend the sensor and a thermometer in a container of cooking oil; then heat the oil.

■NOTE: Neither the sensor nor the thermometer should be allowed to touch the bottom of the container or inaccurate readings will occur. Use wire holders to suspend the sensor and thermometer.

⚠ WARNING

Wear insulated gloves and safety glasses. Heated oil can cause severe burns.

3. If the readings are not as indicated, the sensor must be replaced.

Oil Temperature	Ohms
-20° C (-4° F)	28.6k
40° C (104° F)	1.46k-3.51k
100° C (212° F)	0.176k

4. Install the sensor and tighten securely; then connect the leads.

SPEED SENSOR

■NOTE: Prior to testing the speed sensor, inspect the three-wire connector on the speed sensor for contamination, broken pins, and/or corrosion.

1. Set the meter selector to the DC Voltage position.
2. With appropriate needle adapters on the meter leads, connect the red tester lead to the orange wire; then connect the black tester lead to the black wire.
3. Turn the ignition switch to the ON position.
4. The meter will typically show battery voltage.
5. Leave the black tester lead connected; then connect the red tester lead to the pink/white wire.
6. Slowly move the vehicle forward or backward; the meter must show near 0 and battery voltage alternately.

To replace a speed sensor, use the following procedure:

1. Disconnect the three-wire connector from the speed sensor; then remove the cap screw securing the sensor to the sensor housing.
2. Remove the sensor from the sensor housing accounting for an O-ring.
3. Install the new speed sensor into the housing with new O-ring lightly coated with multi-purpose grease; then secure the sensor with the cap screw (threads coated with blue Loctite #242). Tighten securely.

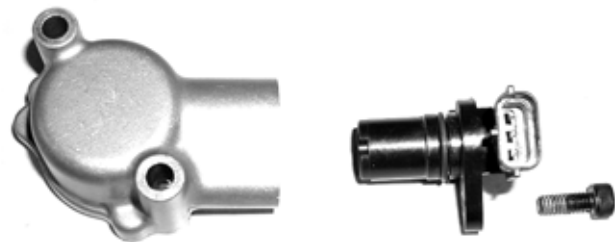

FUEL PUMP/FUEL LEVEL SENSOR

Component data can be retrieved using the Dealer Diagnostic Service. Utilize the Sensor Data screen.

■The fuel pump and fuel level sensor are only serviceable as assemblies.

Testing

WARNING

Whenever any maintenance or inspection is made on the fuel system during which there may be fuel leakage, there should be no welding, smoking, open flames, etc., in the area.

AT THIS POINT

Prior to removing the electric fuel pump, the following check should be performed to determine that removal is necessary.

1. Turn the ignition switch ON and listen for a momentary “whirring” sound of the pump building pressure. If the sound is heard (several seconds), no electrical checks are necessary. Turn the ignition switch OFF.

WARNING

Gasoline may be under pressure. Depressurize the fuel system by disconnecting the fuel pump electrical connector and running the engine until it stalls. Place an absorbent towel around the connector to absorb any gasoline when disconnecting.

2. Disconnect the fuel hose from the gas tank; then install a suitable pressure gauge.



PK191

3. Reconnect the fuel pump electrical connector; then turn the ignition switch to the ON position. The fuel pressure should build until the pump shuts off. Pressure should read 3.0 kg-cm² (43 psi).
4. If the pump is not running, disconnect the fuel pump/sensor connector.
5. Connect a multimeter to the power supply leads with the red tester lead to the orange/red wire and the black tester lead to the black wire; then turn the ignition switch to the ON position. The meter should read battery voltage. If battery voltage is indicated and the fuel pump does not run, replace the pump assembly. If no battery voltage is indicated, check the ECM and the vehicle tilt sensor.

Removing

1. Remove the key from the ignition switch.

WARNING

Always ensure that power cannot be inadvertently applied to the ignition/ECM when working on the fuel system. If the ignition switch is turned on, the electric fuel pump will start and gas could be rapidly pumped and spilled resulting in fire and severe injury.

2. Remove the seat and access panel located at the bottom of the passenger side storage tray; then disconnect the negative cable from the battery.
3. Disconnect the electrical plug from the main harness; then disconnect the fuel hose connector from the fuel pump.
4. Mark the fuel pump mounting and gas tank for installing purposes; then remove the screws securing the fuel pump to the gas tank and remove the fuel pump. Account for the seal.

CAUTION

Take care not to damage the float or float arm or replacement of the entire assembly will be necessary.

5. Using duct tape or other suitable means, cover the fuel pump opening.

Inspecting

AT THIS POINT

If the pump has failed earlier test and must be replaced, proceed to **INSTALLING**.

1. Inspect the fuel screen and blow clean with low pressure compressed air.
2. Move the float lever and check for free movement. The float assembly should return to the lower position without force.
3. Test the fuel level sensor by connecting a multimeter (A) to the fuel level sensor leads (B); then select OHMS. The multimeter should show 101 ohms at full fuel position (C) and 3 ohms at empty fuel position (D).

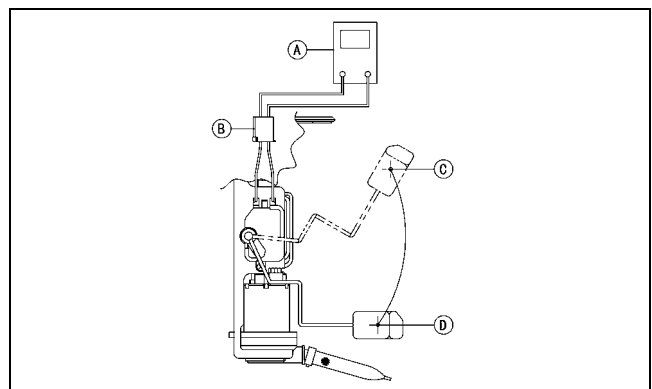

ATV2116

■**NOTE:** If readings are erratic, clean the resistor wiper and resistor with clean alcohol and retest. If still not correct, replacement of the fuel pump level sensor may be necessary.

Replacing

To replace the fuel level sensor, use the following procedure:

1. Cut the two blue wires (A) in the location shown.

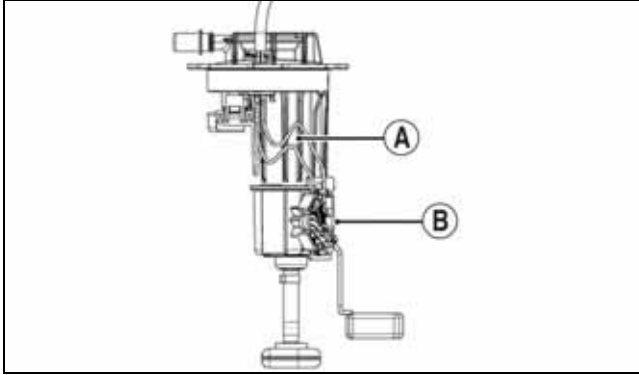

XR257A

2. Slide the existing sender assembly (B) up and off the fuel pump assembly housing.
3. Keeping the float attached to the float arm, remove the float arm from the existing fuel level sensor. Press the float arm into the new fuel level sensor assembly. Ensure it locks into place.

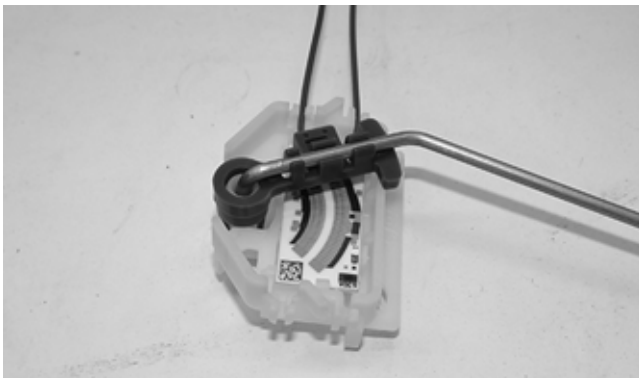

XM366

■NOTE: Inspect the float for any damage or leaking by submerging in water and looking for any air bubbles. Replace if damaged.

4. Install the fuel level sensor assembly onto the fuel pump assembly housing. Once inserted, press down to make sure it locks into place.

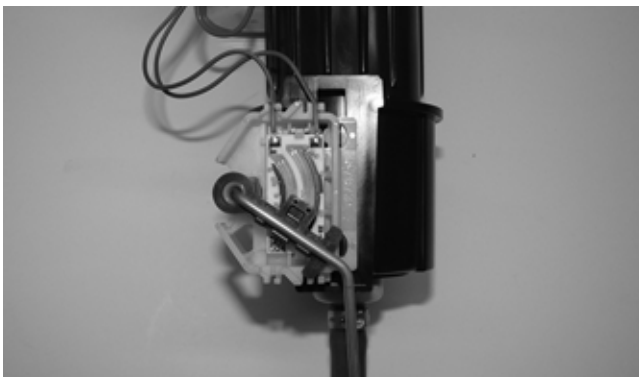

XR258

5. Connect the blue wires using the supplied splice connectors from the fuel level sensor kit. Secure the wires.

Installing

1. Place the fuel pump assembly into the gas tank with a new gasket aligning the match marks; then secure with the six screws. Tighten securely.

■NOTE: It is important to install the fuel pump with the correct orientation to ensure adequate float lever clearance.

2. Connect the fuel hose connector to the fuel pump pipe; then connect the electrical plug to the main harness.
3. Connect the negative battery cable; then turn the ignition switch to the ON position and verify that no gas leaks are present, the pump runs for several seconds, and the gas gauge reading is normal.
4. Start the engine to verify proper engine operation; then shut off the engine and install the seat base, seat back, and seat.

TILT SENSOR

⚠ WARNING

Incorrect installation of the tilt sensor could cause sudden loss of engine power which could result in loss of vehicle control resulting in injury or death.

CAUTION

Do not drop the tilt sensor as shock can damage the internal mechanism.

Supply Voltage

1. Disconnect the three-wire connector from the sensor; then select DC Voltage on the multimeter and connect the red tester lead to the orange/blue wire (C) and the black tester lead to the pink/black wire (A).

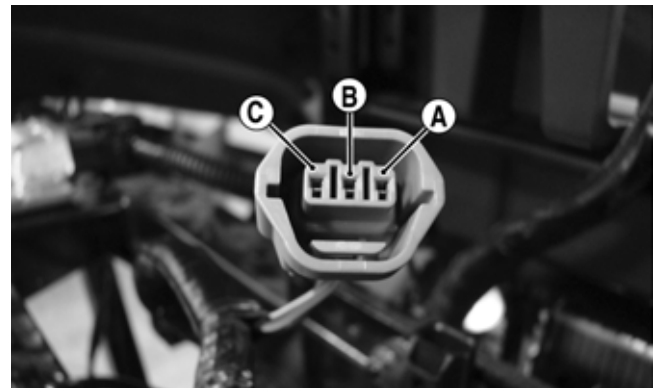

PK299A

2. Turn the ignition switch to the ON position. The multimeter should read approximately 5 VDC. If battery voltage is not indicated, check the connectors, pins, or wiring harness.
3. Remove the red tester lead and connect to the blue/brown wire. The multimeter should read less than 0.02 DC volts. If the specified voltage from steps 2 and 3 are not indicated, check wire connections at the ECM or substitute another ECM to verify the test.

Output Voltage

■NOTE: Needle adapters or Maxi-Clips will be required on the multimeter leads as the following tests are made with the sensor connected:

1. Connect the three-wire plug to the sensor.



PK300

2. Install the needle adapters to the multimeter leads; then select DC Voltage on the multimeter.
3. Connect the red tester lead to the blue/brown wire (B) and the black tester lead to the pink/black wire (A); then turn the ignition switch ON and observe the meter. The meter should read approximately 0.75 DC volts in the upright position.

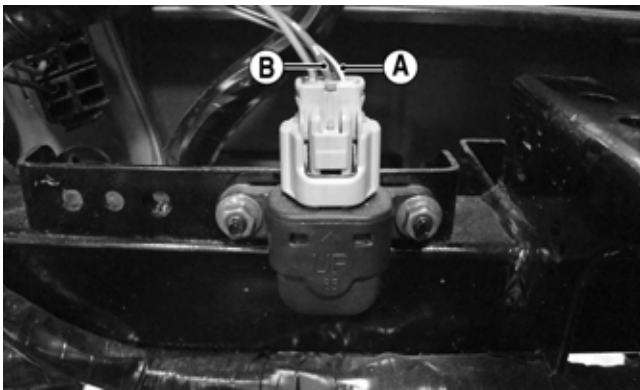

PK300A

4. Remove the two nuts securing the tilt sensor to the frame; then tilt the sensor 60° or more to the left and right observing the meter. The meter should read approximately 3.9 DC volts after approximately one second in the tilted position. If the meter readings are not as specified, the tilt sensor is defective.



PK300B

■NOTE: When replacing the sensor after testing, make sure the arrow marking is directed up.

THROTTLE POSITION SENSOR (TPS)

Component data can be retrieved using the Dealer Diagnostic Service. Utilize the Sensor Data screen.

■NOTE: Preliminary checks may be performed on this component using the diagnostic mode on the LCD gauge (see EFI Diagnostic System in this section).

Verifying TPS Adjustment Tool

Before using the TPS adjustment tool, verify its battery condition. The battery used in the tool is a 9-volt battery. To check battery condition, use a digital volt/ohmmeter set on DC volt scale. Test between the adjustment tool black and red jacks. Insert the red lead of the digital voltmeter into the red jack of the adjustment tool and the black lead of the digital voltmeter into the black jack of the adjustment tool. The green power light of the analyzer should now be illuminated. If voltage is found below 4.9 volts, replace the battery.

■NOTE: The Test Harness must be plugged into the analyzer for testing voltage. Always verify battery voltage is at least 4.9 DC volts before testing TPS.

Testing

1. Remove the seat; then disconnect the three-pin wire TPS connector plug.

■NOTE: Prior to testing the TPS, inspect the three-wire plug connector on the main harness and the three-pin plug on the TPS for contamination, broken pins, and/or corrosion.

2. Connect the TPS Multi-Analyzer Harness connector #8 to the TPS; then connect the harness to the TPS Analyzer Tool.



XR410

3. Using a multimeter, connect the tester to the analyzer as shown in the table below; then select the DC Voltage position. With the vehicle off and throttle at idle, the gauge should read as shown and at Wide-Open Throttle it should read up to as shown.

Tester Lead	Analyzer Socket	Idle (DC Volts)	WOT (DC Volts)
Black	GND	0.66-0.70	3.98
Red	VAR		



PK301

■NOTE: If the throttle body, ECM, TPS, or ISC are replaced, the EFI system must be synchronized. Use the following procedure:

1. With the key off, depress accelerator pedal to Wide Open Throttle (WOT).
2. Place the ignition key in the ON position and wait for 10 seconds.
3. Release the accelerator pedal and wait an additional 10 seconds.
4. Turn the key to the OFF position and allow the gauge to shut off.

RPM Limiter

Component data can be retrieved using the Dealer Diagnostic Service. Utilize the Sensor Data screen.

■NOTE: The ROV is equipped with an ECM that cuts fuel spray and spark when maximum RPM is approached. When the RPM limiter is activated, it could be misinterpreted as a high-speed misfire.

NOTE: If the driver's seatbelt is not fully engaged, vehicle speed will be limited to 15 mph (24 km/h) and the seatbelt indicator light will remain illuminated.

Gear	Park	Neutral	Reverse	High/Low	Fail-Safe Mode
2WD	2250	6500	4500	7650	4500
4WD					
4WD Lock					
2WD Override			5500		
4WD Override			7000		
Differential -Lock Override					

Stator Coil

VOLTAGE (AC Generator — No Load)

The black three-pin connector is located on the right side of the engine.

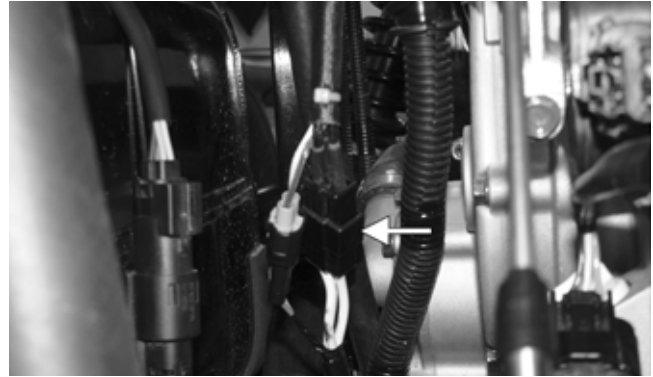

PK302A

■NOTE: Test the connector coming from the engine.

1. Set the meter selector to the AC Voltage position.
2. Test between the three black wires for a total of three tests.
3. With the shift lever set to neutral and the engine running at a constant 5000 RPM, all wire tests must be within specification of approximately 75 VAC.

CAUTION

Do not run the engine at high RPM for more than 10 seconds.

RESISTANCE (AC Generator)

CAUTION

Always disconnect the battery when performing resistance tests to avoid damaging the multimeter.

1. Set the meter selector to OHMS position.
2. Test between the three black wires for a total of three tests.
3. The meter reading must be less than one ohm.

Regulator/Rectifier

The regulator/rectifier is located on the cross-member of the frame in the front right fender well. Verify all other charging system components before the regulator/rectifier is replaced.

TESTING VOLTAGE

1. Start engine and warm up to normal operating temperatures; then connect a multimeter (set at the DC Voltage position) to the battery as follows.
2. Connect the red tester lead to the positive battery post and the black tester lead to the negative battery post.

- Slowly increase RPM. The voltage should increase with the engine RPM. The charging voltage should be greater than resting battery voltage (key off). The charging voltage should not exceed a maximum of 15.0 DC volts.

CAUTION

Do not run the engine at high RPM for more than 10 seconds.

■NOTE: If voltage rises above 15.0 DC volts, the regulator is faulty or a battery connection is loose or corroded. Clean and tighten battery connections or replace the regulator/rectifier. If voltage does not rise, replace the regulator/rectifier.

Starter Motor

■NOTE: The starter motor is only serviceable as an assembly.

REMOVING

- Disconnect the battery.

CAUTION

Always disconnect the negative battery cable from the battery first; then disconnect the positive cable.

- Remove the nut securing the positive cable to the starter; then remove the cable from the starter.
- Remove the two cap screws securing the starter with ground wires to the crankcase; then remove the starter. Account for the wiring forms and an O-ring.

INSTALLING

- Apply a small amount of grease to the O-ring seal on the starter; then install the starter into the crankcase. Secure with two machine screws and wiring forms.
- Secure the positive cable to the starter with the nut.
- Connect the battery. Positive cable first, then negative.

TESTING VOLTAGE

Perform this test on the starter positive terminal. To access the terminal, slide the boot away.

■NOTE: The ignition switch must be in the ON position, and the shift lever in the NEUTRAL position.

- Set the meter selector to the DC Voltage position.
- Connect the red tester lead to the starter terminal; then connect the black tester lead to ground.
- With the starter switch engaged, the meter must show battery voltage and the starter should operate.

■NOTE: The meter will read slightly low due to the normal electrical draw of the starter motor.



PK303

■NOTE: If the meter showed correct voltage but the starter motor did not operate or operated slowly, troubleshoot all starting system components before replacing the starter motor.

■NOTE: If the meter showed no battery voltage, inspect the battery voltage (at the battery), 30-amp main fuse in the PDM, starter switch, starter relay, or main wiring harness.

Starter Relay

- Remove the seat and battery box cover; then, using the multimeter set to the DC Voltage position, check the relay as follows.
- Connect the red tester lead to the positive battery terminal; then connect the black tester lead to the starter cable connection on the starter relay. The meter must show battery voltage.

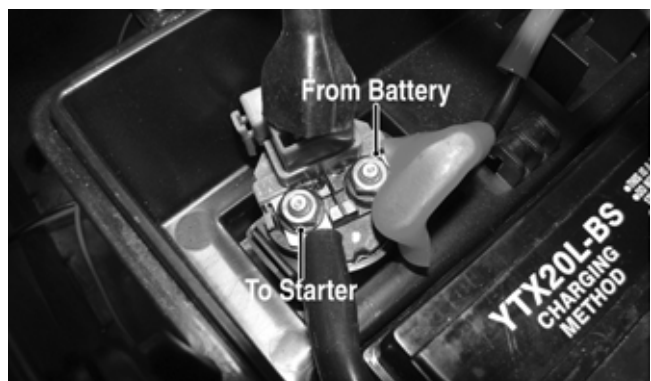

PK304A

■NOTE: Make sure the ignition switch is in the ON position and the transmission in neutral.

- Depress the starter button while observing the multimeter. The multimeter should drop to near 0 volts and a “click” should be heard from the relay.

■NOTE: If a “click” is heard and more than one volt is indicated by the multimeter, replace the starter relay. If no “click” is heard and the multimeter continues to indicate battery voltage, proceed to step 4.

- Disconnect the two-wire connector from the starter relay; then connect the red tester lead to the yellow/green wire and the black tester lead to the green wire.

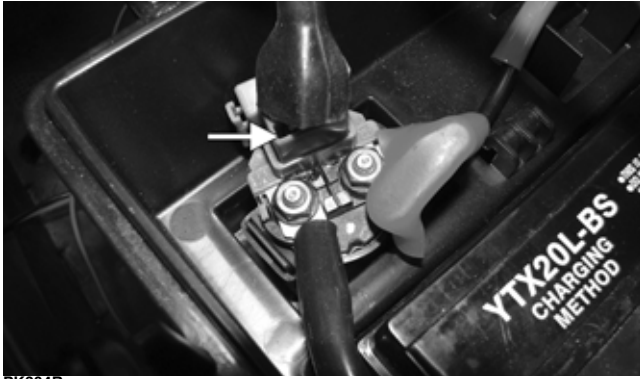

PK304B

- Engage the starter switch and observe the multimeter. The meter must show battery voltage.

■NOTE: If battery voltage is indicated, replace the starter relay.

Electronic Control Module (ECM)

The ECM is located beneath the dash and can be accessed by removing the front right splash panel.

■NOTE: The ECM is only serviceable as an assembly.

The ECM is rarely the cause for electrical problems; however, if the ECM is suspected, substitute another ECM to verify the suspected one is defective.

This EFI system has a built-in feature that will only allow an ECM of the same part number to be used in this model. Do not attempt to substitute an ECM from a different model as the system will not allow it to start.

Error codes can be cleared by following the procedures located in the EFI Diagnostic System sub-section in this section.

■NOTE: If the throttle body, ECM, TPS, or ISC are replaced, the EFI system must be synchronized. Use the following procedure:

- With the key off, depress accelerator pedal to Wide Open Throttle (WOT).
- Place the ignition key in the ON position and wait for 10 seconds.
- Release the accelerator pedal, and wait an additional 10 seconds.
- Turn the key to the OFF position and allow the gauge to shut off.

EFI Diagnostic System

DIGITAL GAUGE

The digital gauge can be used as a diagnostic tool for many of the DTCs displayed. To place the gauge into the diagnostic mode, use the following procedure:

- Turn the ignition switch ON.
- Depress and hold both left and right buttons together for approximately three seconds until “DIAGNOSTIC” appears on the LCD.



WT541

- Press the center button (SELECT) to enter diagnostic mode; cycle the display by pressing either the left or right button to step to the desired function.

■NOTE: The gauge can be utilized dynamically (engine running/vehicle moving) or statically (engine/vehicle stopped).

DIAGNOSTIC MODES

Battery (BATTERY)



WT540

Display: System DC voltage.

DTC: P0562, P0563, P2531, P2532

Usage: Verify system voltage under the following conditions:

- Battery voltage with engine and accessories off (>12.2 VDC for fully charged).
- Battery voltage with engine idling (charging = 13.8 VDC or greater).
- Battery voltage with electrical accessories operating, engine idling (13.5 VDC or greater).
- Battery voltage starter cranking (10.5-11.5 VDC).

Coolant (COOLANT)



WT591

Display: Engine coolant temperature as measured by the ECT sensor.

DTC: P0116, P0117, P0118, P0119

Usage: Monitor coolant temperature to verify the following:

1. ECT sensor signal.
2. High Temperature indicator (on @ 230° F/110° C.)
3. Thermostat opening @ approximately 180° F (82° C), indicated by a momentary drop or pause in the rising temperature reading.
4. Fan ON @ 194° F (90° C), OFF @ 185° F (85° C):
 - A. fan motor
 - B. fan relay
 - C. fan fuse
 - D. wiring connections
5. High Temperature Rev Limiter 4500 RPM @ 230° F (110° C).

Inlet Air Temperature (INTAKE)



WT592

Display: Inlet air temperature in Fahrenheit or Celsius.

DTC: P0112, P0113, P0114

Usage: Verify correct output of IAT sensor.

■NOTE: After engine has been running, IAT readings will be higher than outside air temperature due to engine and engine compartment heat as well as intake manifold heating.

MAP (AIR PRESS)



WT602

Display: MAP in millibars and in./Hg.

DTC: P0107, P0108

Usage: Verify barometric pressure signal correct.

■NOTE: Local barometric pressure is given in in./Hg (inches of mercury) and millibars. The gauge should display approximately 965 millibars at 970 ft. (300 m) above sea level. This number will not change when the engine is started. However, the value is being observed internally in the ECM.

Idle Step Control (ISC)



WT542

Display: ISC position

DTC: P0508, P0509

Usage: Verify correct ISC position.

TPS (TPS)



WT539

Display: TPS position (0% closed, 95-100% WOT).

DTC: P0121, P0122, P0123

Usage: Verify TPS signal and adjust throttle cable.

Fuel Sensor (FUEL)



WT545

Display: Fuel level signal from the fuel level sensor.

DTC: C1400, C1401, C1402

Usage: Check output of the fuel level sensor.*

1. Full fuel is indicated by a reading of 101 ohms.
2. Empty is indicated by a reading of 3 ohms.

* 110-500 ohms, suspect the fuel level sensor or wiring. 0-100 ohms but no gauge indication, suspect the gauge.

Tachometer (RPM)



WT544

Display: Engine RPM

DTC: P0336, P0337, P0339

Usage: Verify engine speed signal from the following:

1. CKP (crankshaft position) sensor to ECM
2. ECM (CAN) signal to gauge (tachometer)
3. ECM (CAN) signal to EPS

Speedometer (SPEED)



WT543

Display: Vehicle speed signal.

DTC: P0500

Usage: Verify speedometer sensor signal from the following:

1. Speed sensor to ECM.
2. ECM (CAN) signal to gauge (speedometer/odometer).
3. ECM (CAN) signal to EPS

DIAGNOSTIC TROUBLE CODES (DTC)

If an EFI or related chassis component fails or an out-of-tolerance signal is detected by the ECM, a diagnostic trouble code (DTC) will be generated in the ECM and displayed on the LCD. The DTC will be displayed alternately with a wrench icon or malfunction indicator light (MIL). The DTC will continue to flash, until the malfunction is corrected and the code cleared.

Code List

■NOTE: Each of the following numerical codes will have a one-letter prefix of C, P, or U. A “C” prefix denotes a chassis malfunction, a “P” prefix denotes a power train malfunction, and a “U” prefix denotes a loss of communication with the gauge.

■NOTE: Normal malfunction codes are cleared from the LCD when the component is replaced or the malfunction is corrected; however, intermittent codes must be cleared as noted in the code chart.

Code	Fault Description	Possible Cause	Fault Recovery Method
C0063	Tilt Sensor Circuit High	Sensor or interconnect harness shorted to battery power	Correct condition*
C0064	Tilt Sensor Circuit Low/SG/Open	Sensor or interconnect harness open or shorted to chassis ground	Correct condition*
P0030	O2 Heater Intermittent/Open	Heater or interconnect harness intermittent or open	Correct condition*
P0031	O2 Heater Low/SG	Heater or interconnect harness shorted to chassis ground	Correct condition*
P0032	O2 Heater High/SP	Heater or interconnect harness shorted to battery power	Correct condition*
P0107	MAP Sensor Circuit Low/SG/Open	Sensor or interconnect harness shorted to chassis ground	Correct condition*
P0108	MAP Sensor Circuit High/SP	Sensor or interconnect harness shorted to battery power	Correct condition*
P0112	IAT Sensor Circuit Low/SG	Sensor or interconnect harness shorted to chassis ground	Correct condition*
P0113	IAT Sensor Circuit High/Open	Sensor or interconnect harness open or shorted to battery power	Correct condition*
P0114	IAT Sensor Circuit Intermittent	Sensor or interconnect harness intermittent	Correct condition*
P0116	ECT Sensor Circuit Range/Performance	Sensor producing an out-of-range voltage	Correct condition*
P0117	ECT Sensor Circuit Low/SG	Sensor or interconnect harness shorted to chassis ground	Correct condition*
P0118	ECT Sensor Circuit High/Open/SP	Sensor or interconnect harness open or shorted to battery power	Correct condition*
P0119	ECT Sensor Circuit Intermittent	Sensor or interconnect harness intermittent	Correct condition*
P0121	TPS Range/Performance	Sensor producing an out-of-range voltage	Correct condition*
P0122	TPS Circuit Low/SG	Sensor or interconnect harness shorted to chassis ground	Correct condition*
P0123	TPS Circuit High	Sensor or interconnect harness open or shorted to battery power	Correct condition*
P0130	O2 Sensor Intermittent/Open	Sensor or interconnect harness intermittent or open	Correct condition*
P0131	O2 Sensor Low/SG or Air-Leak	Sensor or interconnect harness shorted to chassis ground or an air-leak exists	Correct condition*
P0132	O2 Sensor High/SP	Sensor or interconnect harness shorted to battery power	Correct condition*
P0171	O2 Feedback Below Minimum Correction	Low fuel rail pressure, dirty fuel filter, or dirty injectors	Correct condition*
P0172	O2 Feedback Exceeds Maximum Correction	Excessive fuel rail pressure, MAP or temp sensors out-of-spec	Correct condition*
P0219	Engine Over-Speed Condition	Engine speed (RPM) has exceeded the ECM over-speed set point/limit	Reduce engine speed
P0231	Fuel Pump Relay Circuit Low/SG/Open	Relay has been removed or interconnect harness shorted to chassis ground	Correct condition*
P0232	Fuel Pump Relay Circuit High	Relay or interconnect harness shorted to battery power	Correct condition*
P0233	Fuel Pump Relay Circuit	Relay circuit erratic or intermittent	Correct condition*
P0261	Rear Cylinder Fuel injector Circuit Low/SG	Injector or interconnect harness shorted to chassis ground	Correct condition**
P0262	Rear Cylinder Fuel injector Circuit High	Injector or interconnect harness shorted to battery power	Correct condition**
P0263	Rear Cylinder Fuel injector Balance/Open	Injector has been disconnected or interconnect harness open	Correct condition**
P0264	Front Cylinder Fuel injector Circuit Low/SG	Injector or interconnect harness shorted to chassis ground	Correct condition**
P0265	Front Cylinder Fuel injector Circuit High	Injector or interconnect harness shorted to battery power	Correct condition**
P0266	Front Cylinder Fuel injector Balance/Open	Injector has been disconnected or interconnect harness open	Correct condition**
P0336	Crankshaft Angle Sensor Synchronization	Sensor or interconnect harness intermittent	Correct condition**
P0337	Crankshaft Angle Sensor Circuit/SG	Sensor or interconnect harness shorted to chassis ground	Correct condition**
P0339	Crankshaft Angle Sensor Intermittent/Erratic	Sensor or interconnect harness intermittent	Correct condition**
P0340	Camshaft Angle Sensor Synchronization	Sensor or interconnect harness intermittent	Correct condition**
P0341	Camshaft Angle Sensor Circuit/SG	Sensor or interconnect harness shorted to chassis ground	Correct condition**
P0342	Camshaft Angle Sensor Intermittent/Erratic	Sensor or interconnect harness intermittent	Correct condition**
P0480	Fan-Primary/Right Relay Control Circuit	Relay erratic or intermittent	Correct condition*
P0481	Fan-Secondary/Left Relay Control Circuit High	Relay or interconnect harness shorted to battery power	Correct condition*
P0482	Fan-Secondary/Left Relay Control Circuit Low/SG/Open	Secondary fan fuse has blown, the secondary fan relay has been removed or interconnect harness shorted to chassis ground	Correct condition*
P0483	Fan-Secondary/Left Relay Control Circuit	Relay erratic or intermittent	Correct condition*
P0484	Fan-Primary/Right Relay Control Circuit High	Relay or interconnect harness shorted to battery power	Correct condition*
P0485	Fan-Primary/Right Relay Control Circuit Low/SG/Open	Primary fan fuse has blown, the primary fan relay has been removed or interconnect harness shorted to chassis ground	Correct condition*

Code	Fault Description	Possible Cause	Fault Recovery Method
P0500	Vehicle Speed-Sensor	Sensor circuit signal intermittent or missing	Correct condition*, start and drive the vehicle*
P0508	IAC System Circuit Low/SG	IAC interconnect harness shorted to chassis ground	Correct condition*
P0509	IAC System Circuit High/Open	IAC disconnected or the interconnect harness shorted to battery power	Correct condition*
P0520	Engine Oil Sensor/Switch	Sensor or interconnect harness erratic or intermittent	Correct condition*
P0562	System Voltage Low	Battery charge condition low or the regulator/rectifier output low	Correct condition*
P0563	System Voltage High	Battery cable connections are loose or the regulator/rectifier output high	Correct condition*
P0601	ECM CAN Communication Shutdown	Intermittent CAN connections or unstable CAN conditions have caused the ECM to temporarily shutdown CAN communication	Correct CAN communication issue*
P0615	Starter Relay Circuit	Start switch/button, starter relay, gear switch or interconnect harness erratic or intermittent	Correct condition*
P0616	Starter Relay Circuit Low	Start switch/button, starter relay or interconnect harness intermittent or shorted to chassis ground	Correct condition*
P0617	Starter Relay Circuit High	Start switch/button, starter relay or interconnect harness intermittent or shorted to battery power	Correct condition*
P0630	VIN Not Programmed or Incompatible	Verify the LCD gauge and ECM part numbers are correct for the vehicle model number and VIN	Correct gauge and ECM VIN compatibility issue*
P0642	Sensor Power Circuit Low	One or more of the sensors defective or shorted to chassis ground	Correct condition*
P0643	Sensor Power Circuit High	One or more of the sensors defective or shorted to battery power	Correct condition*
P2300	Rear Ignition Coil Primary Circuit Low/SG/Open	Coil or interconnect harness open or shorted to chassis ground	Correct condition**
P2301	Rear Ignition Coil Primary Circuit High	Coil or interconnect harness shorted to battery power	Correct condition**
P2303	Front Ignition Coil Primary Circuit Low/Open	Coil or interconnect harness open or shorted to chassis ground	Correct condition**
P2304	Front Ignition Coil Primary Circuit High	Coil or interconnect harness shorted to battery power	Correct condition**
P2531	Ignition Switch Circuit Low	Battery charge condition low or the regulator/rectifier output low	Correct condition*
P2532	Ignition Switch Circuit High	Battery cable connections are loose or the regulator/rectifier output high	Correct condition*
U0155	LCD Gauge to EFI ECM CAN Communication Lost	Gauge CAN circuit or interconnect harness intermittent or has failed	Correct condition*
U1000	Vehicle Not Registered or Invalid PIN Entered	An invalid registration PIN has been entered	Enter the correct registration PIN*
U1001	Vehicle Not Registered	An invalid registration PIN has been entered	Enter the correct registration PIN*
FUEL OFF	Tilt Sensor Activation Code	Sensor has been activated	Restore the vehicle chassis to an upright position*

High: A high voltage condition has been detected

Low: A low voltage condition has been detected

Intermittent: An intermittent circuit condition has been detected

Open: An open circuit condition has been detected

* After correcting the condition, cycle the key switch On-Off-On

**After correcting the condition, cycle the key switch On-Off-On, start the engine, then cycle the key switch On-Off-On.

Troubleshooting

Problem: Spark absent or weak	
Condition	Remedy
<ol style="list-style-type: none"> 1. Ignition coil defective 2. Spark plug(s) defective 3. CKP sensor defective 4. ECM defective 	<ol style="list-style-type: none"> 1. Replace ignition coil 2. Replace plug(s) 3. Replace CKP sensor 4. Replace ECM
Problem: Spark plug fouled with carbon	
Condition	Remedy
<ol style="list-style-type: none"> 1. Gasoline incorrect 2. Air cleaner element dirty 3. Spark plug(s) incorrect (too cold) 4. Valve seals cracked — missing 5. Oil rings worn — broken 	<ol style="list-style-type: none"> 1. Change to correct gasoline 2. Clean element 3. Replace plug(s) 4. Replace seals 5. Replace rings
Problem: Spark plug electrodes overheat or burn	
Condition	Remedy
<ol style="list-style-type: none"> 1. Spark plug(s) incorrect (too hot) 2. Engine overheats 3. Spark plug(s) loose 	<ol style="list-style-type: none"> 1. Replace plug(s) 2. Service cooling system 3. Tighten plug(s)
Problem: Battery does not charge	
Condition	Remedy
<ol style="list-style-type: none"> 1. Lead wires/connections shorted — loose — open 2. Stator coils shorted — grounded — open 3. Regulator/rectifier shorted 	<ol style="list-style-type: none"> 1. Repair — replace — tighten lead wires 2. Replace stator coils 3. Replace regulator/rectifier
Problem: Battery charges, but charging rate is below the specification	
Condition	Remedy
<ol style="list-style-type: none"> 1. Lead wires shorted — open — loose (at terminals) 2. Stator coils grounded — open 3. Regulator/rectifier defective 4. Cell plates (battery) defective 	<ol style="list-style-type: none"> 1. Repair — tighten lead wires 2. Replace stator coils 3. Replace regulator/rectifier 4. Replace battery
Problem: Magneto overcharges	
Condition	Remedy
<ol style="list-style-type: none"> 1. Battery short circuited 2. Regulator/rectifier defective 3. Regulator/rectifier poorly grounded 	<ol style="list-style-type: none"> 1. Replace battery 2. Replace regulator/rectifier 3. Clean — tighten ground connection
Problem: Charging unstable	
Condition	Remedy
<ol style="list-style-type: none"> 1. Lead wire intermittently shorting 2. Magneto internally shorted 3. Regulator/rectifier defective 	<ol style="list-style-type: none"> 1. Replace lead wire 2. Replace stator coil 3. Replace regulator/rectifier
Problem: Starter does not engage	
Condition	Remedy
<ol style="list-style-type: none"> 1. Battery charge low 2. Switch contacts defective 3. Starter motor brushes not seating 4. Starter relay defective 5. Wiring connections loose — disconnected 6. Start-in-gear/neutral relay defective 	<ol style="list-style-type: none"> 1. Recharge — replace battery 2. Replace switch 3. Replace starter 4. Replace relay 5. Connect — tighten — repair connections 6. Replace relay
Problem: Battery “sulfation” (Acidic white powdery substance or spots on surfaces of cell plates)	
Condition	Remedy
<ol style="list-style-type: none"> 1. Charging rate too low — too high 2. Battery discharged 	<ol style="list-style-type: none"> 1. Replace battery 2. Charge battery
Problem: Battery discharges too rapidly	
Condition	Remedy
<ol style="list-style-type: none"> 1. Charging system (charging operation) not set properly 2. Cell plates overcharged — damaged 3. Battery short-circuited 4. Electrical load too high 	<ol style="list-style-type: none"> 1. Check AC generator — regulator/rectifier — circuit connections 2. Replace battery — correct charging system 3. Replace battery 4. Reduce load
Problem: Battery polarity reversed	
Condition	Remedy
<ol style="list-style-type: none"> 1. Battery incorrectly connected 	<ol style="list-style-type: none"> 1. Reverse connections — replace battery

Drive System

GENERAL INFORMATION

Gear cases are 3.6:1.

■NOTE: Never reuse a lock nut. Once a lock nut has been removed, it must be replaced with a new lock nut.

SPECIAL TOOLS

A number of special tools must be available to the technician when performing service procedures in this section. Refer to the current Special Tools Catalog for the appropriate tool description.

■NOTE: When indicated for use, each special tool will be identified by its specific name, as shown in the chart below, and capitalized.

Description	p/n
Backlash Measuring Tool (24-Spline Axle)	0544-010
CV Boot Clamp Tool	Common Tool
Internal Hex Socket	Common Tool
Pinion Gear/Shaft Removal Tool	Common Tool
Gear Case Seal Installer Tool	0444-273
Hub Retaining Wrench	0444-270

■NOTE: Special tools are available from the Service Department.

Front Drive Actuator

■NOTE: The actuator is only serviceable as an assembly.

■NOTE: The actuator will operate only when the ignition switch is in the ON position.

The front drive actuator is located on the right side of the front differential input housing. With the engine stopped and the ignition switch in the ON position, a momentary “whirring” sound can be heard each time the drive select switch is shifted. If no sound is heard, see Electrical System. If the actuator runs constantly or makes squealing or grinding sounds, the actuator must be replaced.

REMOVING

1. Turn the ignition switch to the ON position; then select 2WD LOCK on the drive select switch. Remove the drain plug from the bottom of the differential and allow the fluid to drain; then remove the seat and center floorboard kick panel.
2. Remove the air box and intake tube found below the center floorboard kick panel.

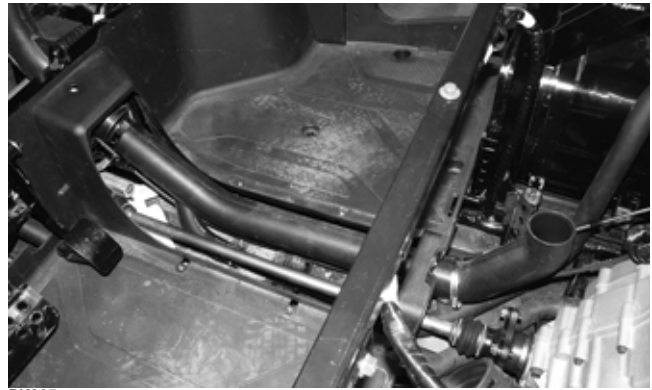

PK305

3. From the rear, remove the two cap screws securing the actuator to the differential and bracket.

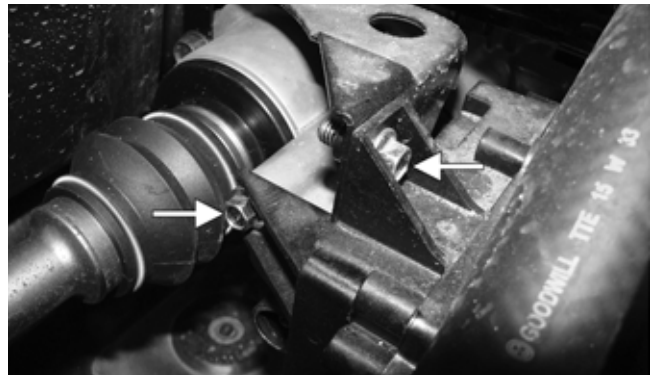

PK306A

4. Remove the rubber access plug found toward the back side of the actuator; then remove the selector shaft circlip and spacer. Discard the circlip.



PK034A



PK035

- Remove the cable tie securing the actuator wiring. Note the location for assembly purposes. Disconnect the actuator connector. Remove the cap screw securing the coolant pipe bracket to the frame.

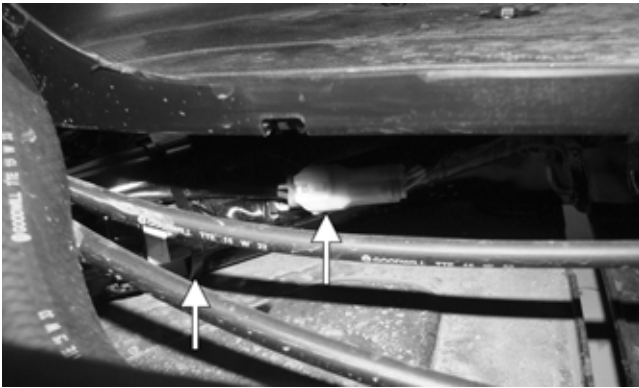

PK307A

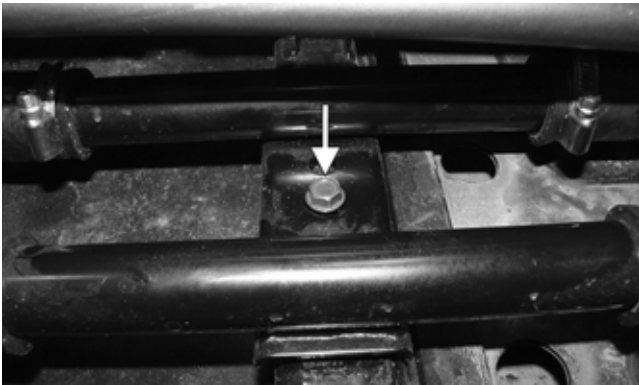

PK308A

- Loosen but do not remove the mounting cap screw at the front of the actuator. Pull the right side coolant hose out of the way; then slide the actuator to the rear to clear the slotted mounting tab and the selector shaft.



PK309



PK310

INSTALLING

- Lubricate the O-rings on the actuator; then ensure all mounting surfaces are clean and free of debris.
- Align the actuator with the selector shaft and slide it forward onto the shaft taking care to engage the cap screw in the slot of the front mounting tab.



PK309

- While holding the actuator firmly forward, tighten the front cap screw to hold the actuator in place; then install but do not tighten the two remaining cap screws.

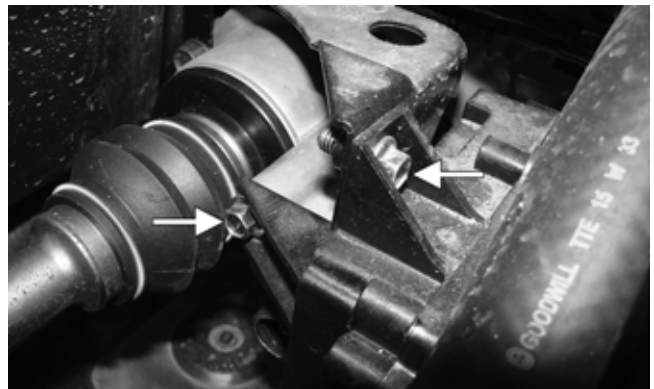

PK306A

- Loosen the front cap screw; then tighten the cap screws on the driveshaft side.

■ **NOTE:** It is important to tighten this cap screw while the others are loose to ensure proper seating of the actuator.

- Tighten the remaining cap screw; then connect the electrical plug to the main harness. Secure the wiring with a new cable tie, as noted in removal.
- Install the spacer on the selector shaft; then secure using a new circlip. Ensure the circlip fully seats to the groove in the selector shaft. Install the rubber plug.



PK035



PK034A

7. Secure the coolant pipe bracket back onto the frame using a cap screw. Install the differential drain plug. Remove the fill and oil level plugs. Add the recommended oil into the differential until fluid emerges from the oil level plug hole. Secure the fill and oil level plugs.
8. Turn the ignition switch to the ON position and check the operation by shifting the drive select switch several times.
9. Install and secure the center intake tube and air box assembly.



PK305A

10. Install the center floorboard kick panel and seat.

Front Differential

REMOVING

1. Remove the front belly panel.
2. Remove the drain plug and drain the gear lubricant into a drain pan; then install the plug and tighten to 45 in.-lb (5.1 N-m).

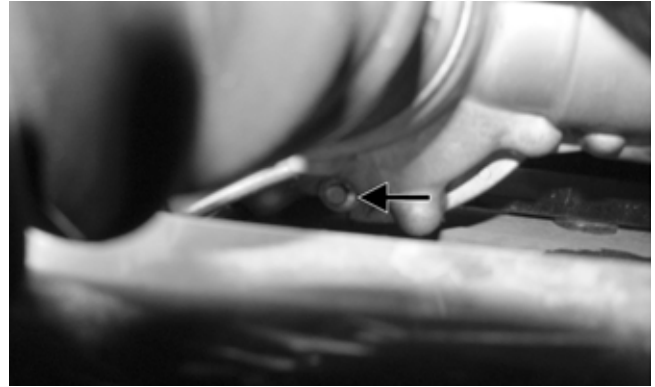

PK029A

3. Remove the hubs (see Hub in this section, steps 1-5).
4. Remove the center floorboard kick panel; then disconnect the front drive actuator connector from the main harness.

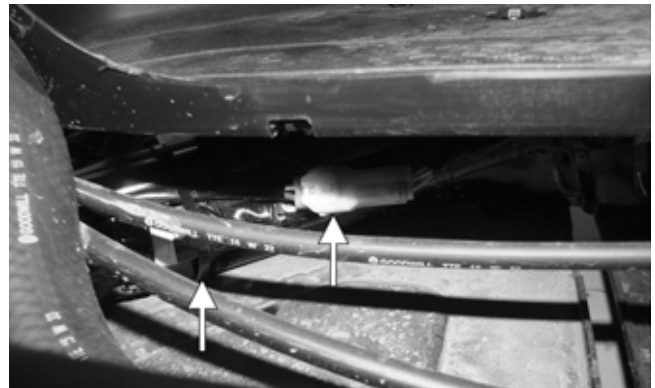

PK307A

5. Remove the lower and upper ball joint cap screws taking care not to strip the threads on the ball joint shaft; then using a rubber mallet, tap the end of the axle and free it from the knuckle assembly.

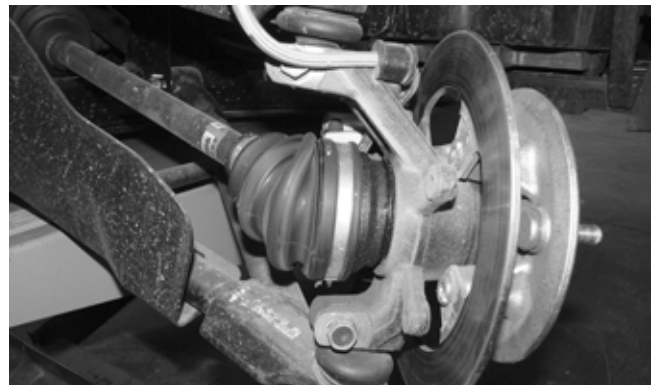

PK005

6. Pull the steering knuckle away from the axle.

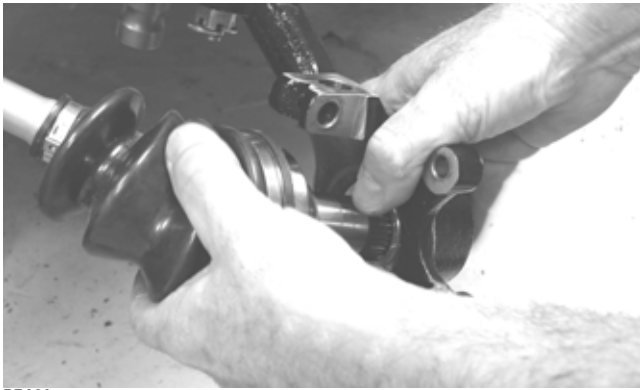

PR222

- Support the axle to prevent it from dropping or hanging.

CAUTION

The axle must be supported. If the axle is allowed to drop or hang, damage to the inner CV joint may occur.

- Use a tie-down to hold the steering knuckle and brake caliper up and out of the way.

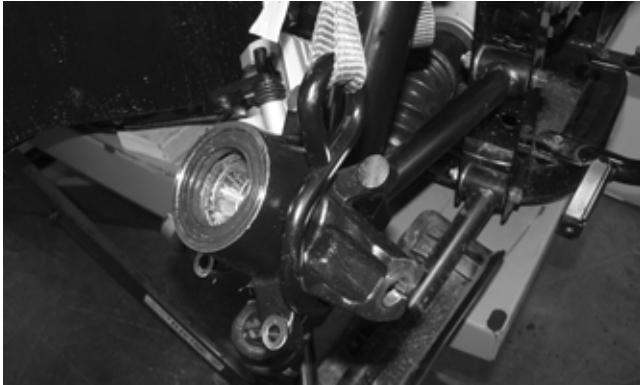

PK311

- Position the axle horizontally and grasp the axle mid shaft; then push the axle slightly in toward the differential. Using a slide hammer type action, pull the axle out from the differential. Remove the axle from the differential. Repeat for the opposite side.



PK233A

■NOTE: The front right axle must be installed in its original location because it is designed with the splined differential lock ring toward the inside of the inner CV joint.

- From below the frame, remove the lower mounting cap screws securing the forward differential bracket to the frame.

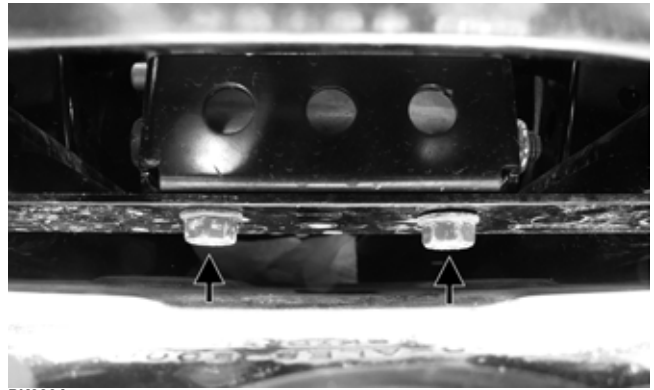

PK230A

- Remove the upper differential mounting cap screw and lock nut. Discard the lock nut.

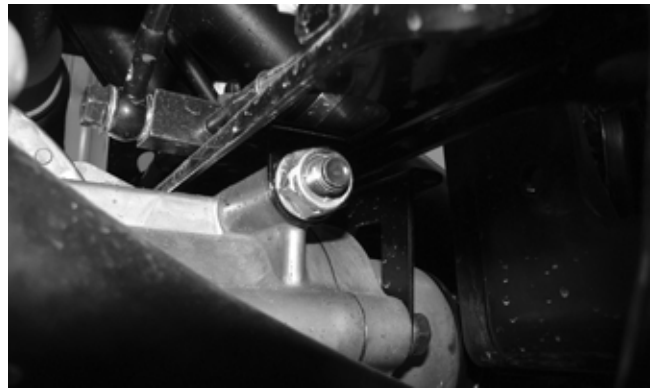

PK231

- Slide the front propeller shaft boot back; then, while holding the shaft in place, slide the differential forward to disengage the splines. Account for the spring.



PK312

- Protect the painted surface of the frame; then tilt the differential assembly on its left side. Remove through the front of the frame.



PK313

Disassembling Input Shaft

1. Remove the actuator (see Front Drive Actuator section).
2. Remove the slotted aluminum plug and account for the O-ring. Remove the differential locking shaft circlip. Account for the circlip, spring retainer, and spring. Note the orientation of these components for assembly purposes.

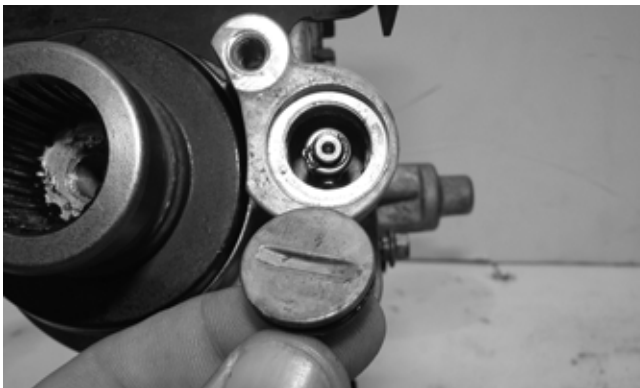

PK036

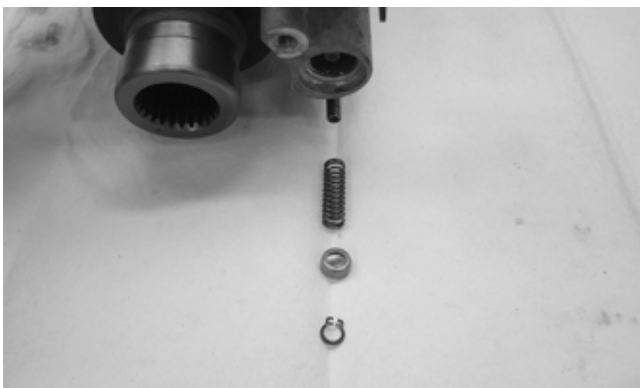

PK037

3. Noting the orientation of the actuator bracket, remove the three cap screws securing the input housing. Using a rubber mallet to loosen the housing from the differential, remove the housing. Account for the dowel pin and gasket.

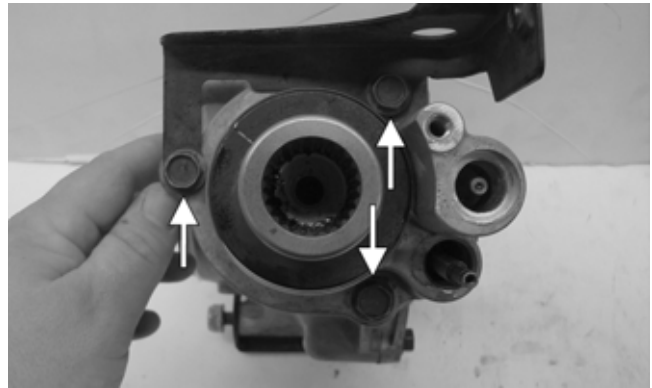

PK038A

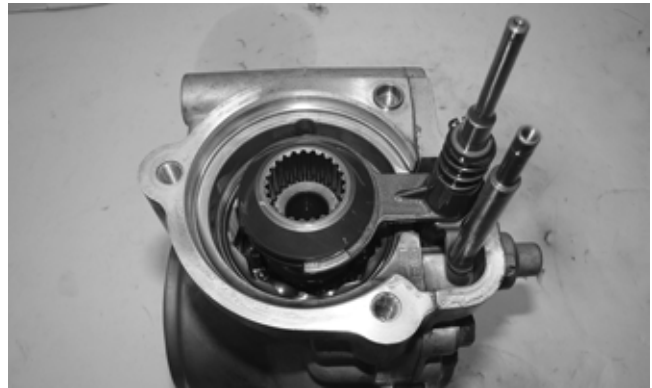

PK039

4. Remove the snap ring securing the input shaft; then slide it out of the housing.



PK040



PK041

5. To gain access to the housing bearing, remove the seal and snap ring from the input shaft housing.

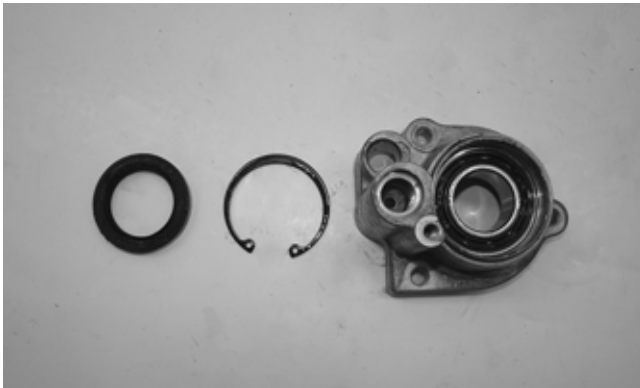

PK042

6. From the opposite side of the housing, use an appropriate sized bearing driver to press the bearing out of the housing.



PK045

2. Install the input shaft seal, making sure it is fully seated in the housing.



PK043

Assembling Input Shaft

1. Using an appropriate sized bearing driver, press a new bearing into the input shaft housing. Secure the bearing with the existing snap ring, making sure the sharp edge of the snap ring faces toward the outside.



GC014

3. Grease the seal; then inspect and clean the sealing surface of the input shaft. Insert the input shaft into the bearing and secure with the snap ring.



PK044



PK041



PK046

4. With the dowel pin in place, set a new gasket into position and secure the pinion housing to the differential with the three cap screws.

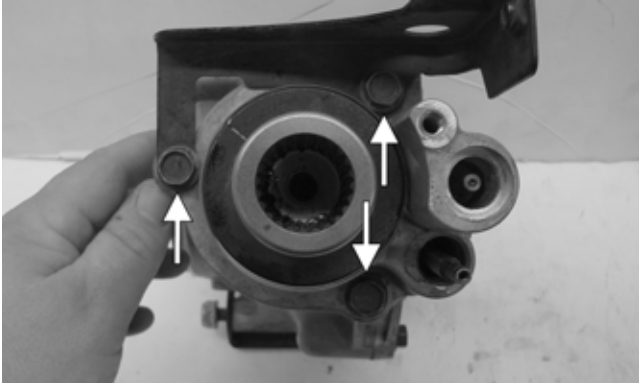

PK038A

5. Install the differential shaft spring and spring retainer; then secure with a new circlip. Thread the plug into the housing.

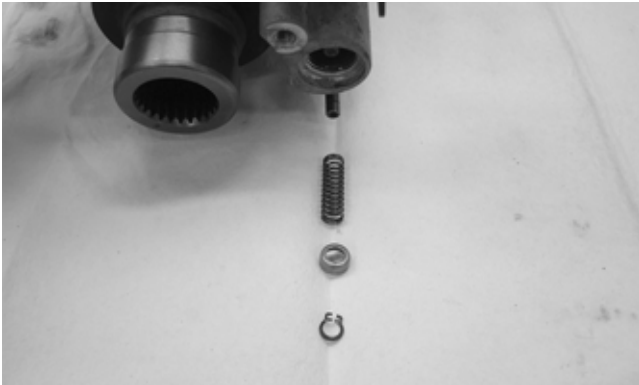

PK037

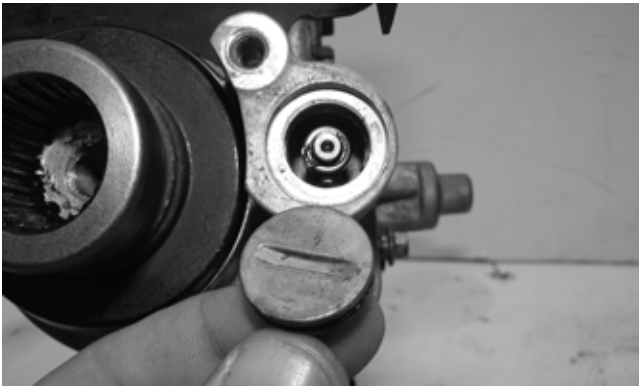

PK036

6. Install the actuator.

Disassembling Differential Assembly

■NOTE: This procedure can be performed on a rear gear case.

1. Remove the input shaft housing (see Disassembling Input Shaft in this section). Account for the slotted plug, circlip, spring cap, spring, fork/push rod assembly, and coupler.



PK205

2. Using a criss-cross pattern, loosen and remove the cap screws securing the differential cover.
3. Using a plastic mallet, tap lightly to remove the differential cover. Account for a gasket and two dowel pins (A).

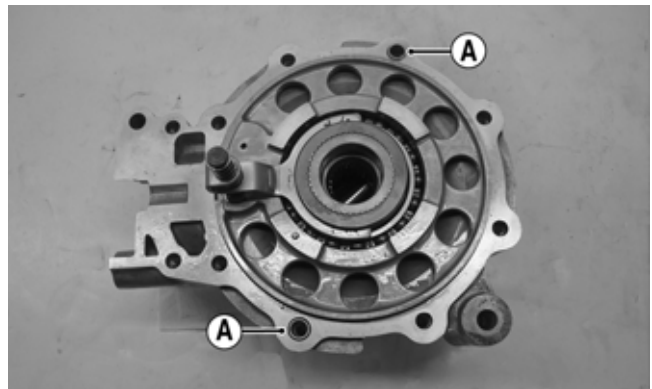

PK206A

■NOTE: If the cover is difficult to remove, pry on the cover in more than one recessed location.

4. Remove the splined coupler, shifter fork, pin, and springs of the differential lock assembly and set aside. Note position of parts for assembling purposes.



PK207

5. Remove the right differential bearing flange assembly and account for a shim. Mark the shim as right-side.

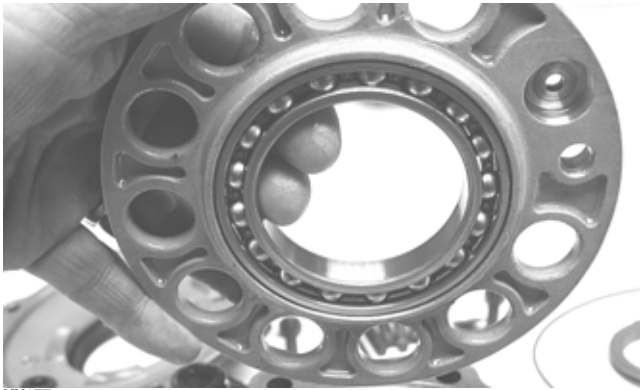

KX177

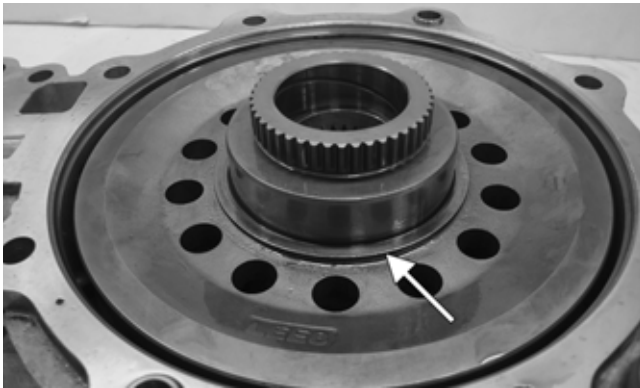

PK208A

6. Place the differential with the open side down; then lift the housing off the spider assembly. Account for shim(s) and mark as left-side.



PK209



KX181

Disassembling Pinion Gear

1. Using the Internal Hex Socket, remove the lock collar securing the pinion bearing in the housing.

■NOTE: Unstake the lock collar if evidence of the process was performed in a previous service.

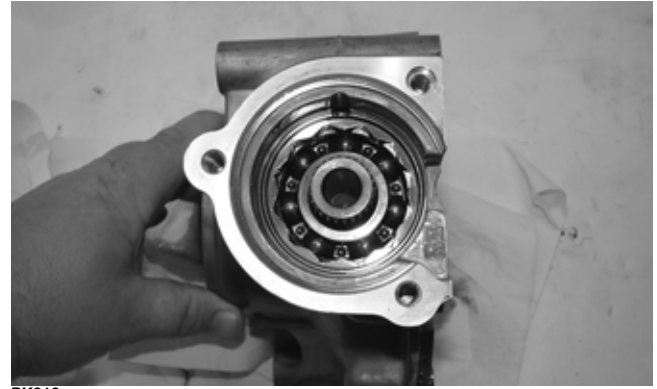

PK210

2. Using the Pinion Gear/Shaft Removal Tool and a hammer, remove the pinion gear from the gear case housing.

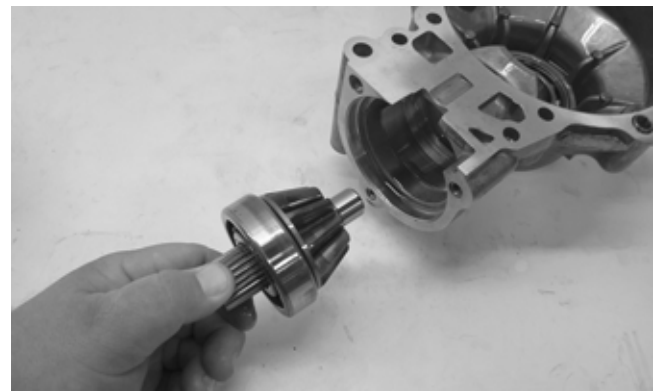

PK211

3. Place the pinion gear in a bearing puller or press blocks; then remove the pinion bearing using a press. Account for a collar and a bearing.

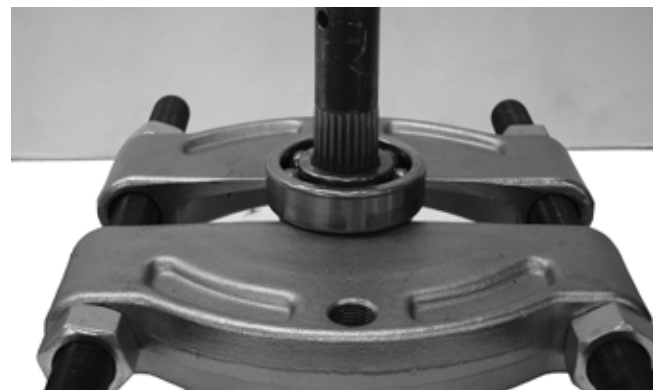

PK212

4. Inspect the pinion gear needle bearing. Using a suitable bearing puller, remove the needle bearing.



PK216

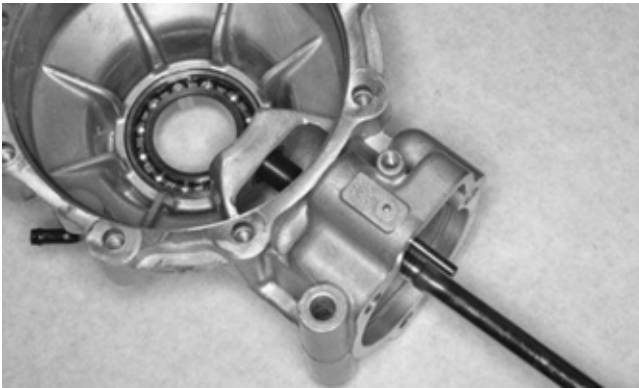

PK217

5. Remove any reusable parts from the gear case housing; then discard the lock collar.

Assembling Pinion Gear

1. Install a new needle bearing by using a suitable sized bearing driver against the outer race of the bearing.

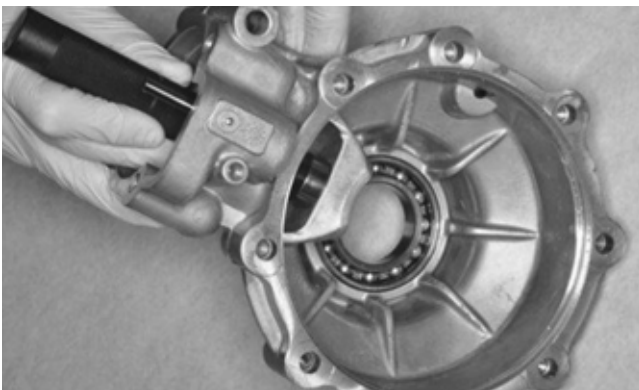

PK218

2. Place the pinion assembly in a bearing puller or press blocks; then install the bearing using a press.

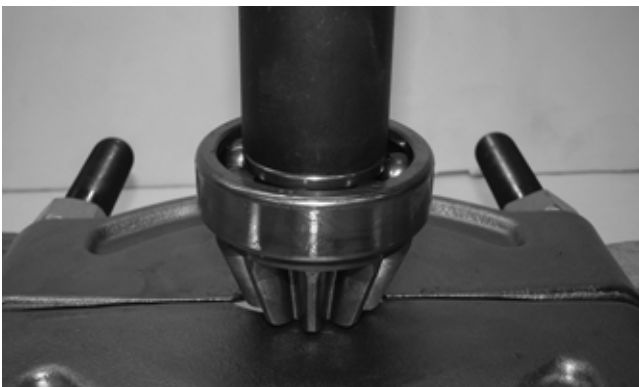

PK213

3. Using a propane torch, heat the gear case housing to approximately 200° F (93° C); then install the pinion assembly.

4. Install a new lock collar and tighten to 125 ft-lb (169.5 N-m). Stake the collar into the gear case.



PK214

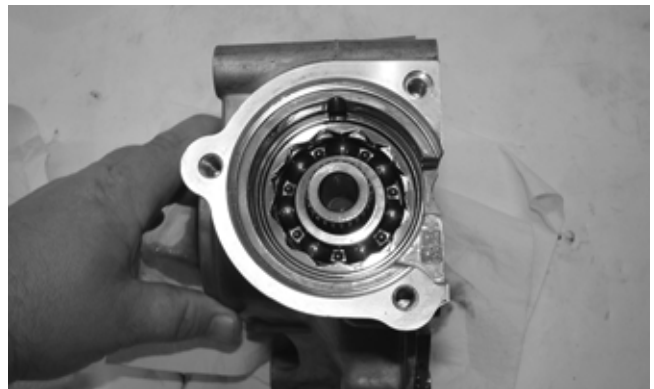

PK210



PK215A

Shimming Procedure/Shim Selection

Case-Side Shims (Backlash)		
p/n	mm	in.
3307-304	1.3	0.051
3307-305	1.4	0.055
3307-306	1.5	0.059
3307-307	1.6	0.063
3307-308	1.7	0.067

Cover-Side Shims (Ring Gear End-Play)		
p/n	mm	in.
3306-132	1.0	0.039
3306-133	1.1	0.042
3306-134	1.2	0.046
3306-135	1.3	0.051
3306-136	1.4	0.055
3306-137	1.5	0.059
3306-138	1.6	0.063
3306-139	1.7	0.067

It is very important to adjust bevel gears for the proper running tolerances. Gear life and gear noise are greatly affected by these tolerances; therefore, it is very important to properly adjust any gear set prior to final assembly.

The following procedure can be used on both front differential or rear drive gear case.

■NOTE: All bearings must be installed in the gear case and the pinion properly installed before proceeding.

Backlash

■NOTE: Always set backlash prior to any other shimming.

1. Install the existing shim or a 0.051-0.055-in. shim on the gear case side of the ring gear assembly.



GC031A

2. Install the ring gear with shim in the gear case; then while holding the pinion stationary, rock the ring gear forward and back to determine if any backlash exists. If no backlash exists, install a thicker shim and recheck.

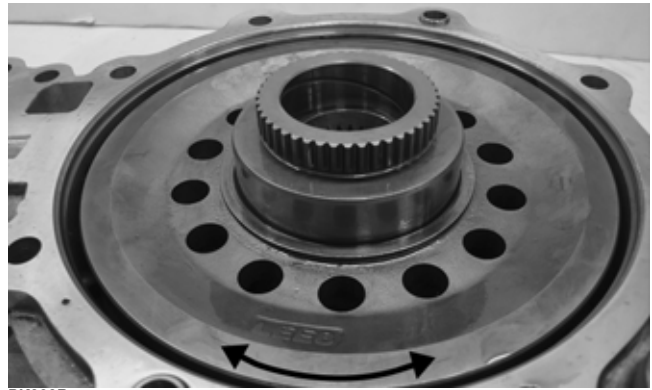

PK208B

3. Install the bearing flange onto the gear case cover making sure the alignment/locating pin engages the locating hole in the cover; then make sure the bearing flange is completely seated in the cover.

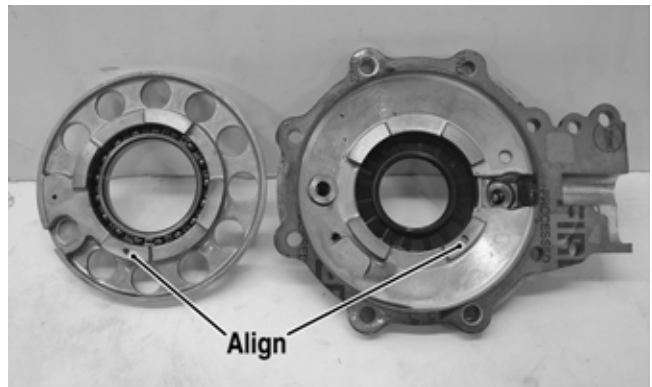

PK219A



GC033A

4. Install the existing shim or a 0.063 in. shim on the cover side of the ring gear; then place the assembled gear case cover onto the gear case and secure with three cap screws. Tighten evenly using a crisscross pattern.

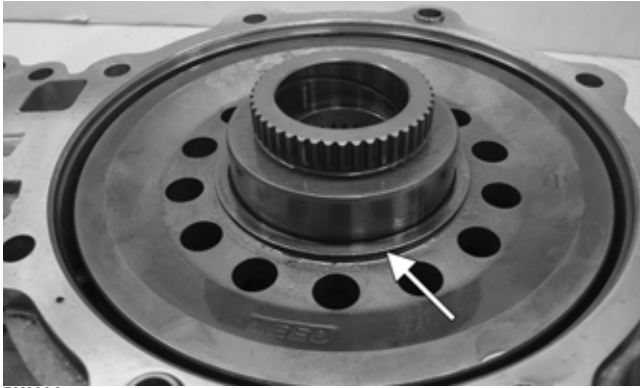

PK208A

- Place the appropriate Backlash Measuring Tool (24 spline axle) into the splines of the ring gear and install a dial indicator making sure it contacts the gauge at a 90° angle and on the index mark.



GC040

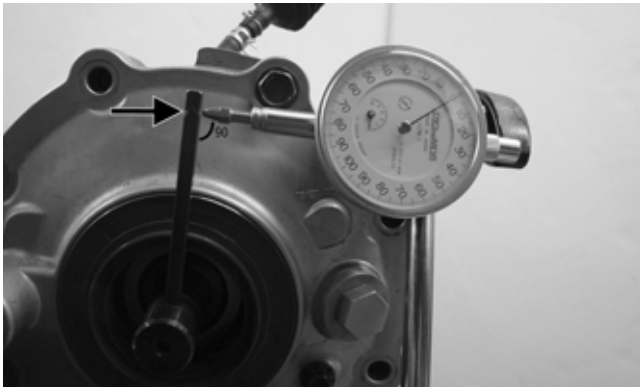

PK220A

- Zero the dial indicator; then while holding the pinion stationary, rock the ring gear assembly forward and back and record the backlash. Backlash must be 0.002-0.010 in. If backlash is within specifications, proceed to Ring Gear End-Play.

■NOTE: If backlash is not within specifications, increase the case side shim thickness and decrease the cover side shim thickness. To decrease the backlash, decrease the case side shim thickness and increase the cover side shim thickness.

■NOTE: Higher backlash settings usually result in quieter gear operation.

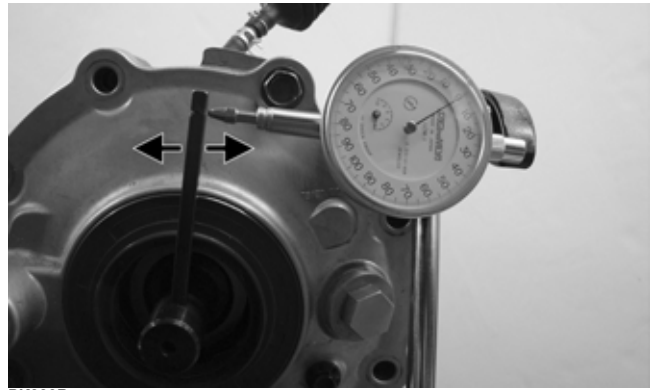

PK220B

Ring Gear End-Play

After correcting backlash, ring gear end-play can be adjusted. To adjust end-play, use the following procedure:

- Secure the gear case in a holding fixture with the cover side up; then install a dial indicator contacting the ring gear axle flange.



PK221

- Zero the dial indicator; then push the ring gear toward the dial indicator and release. End-play should be 0.004-0.008 in.
- To increase end-play, decrease the cover side shim thickness. To decrease end-play, increase the cover side shim thickness.

■NOTE: Once proper backlash and end play are established, the gear case can be assembled.

Assembling Differential Assembly

- With the pinion gear and new bearings installed, place the selected (backlash) shim on the gear case side of the ring gear with the chamfered side toward the ring gear; then install into gear case/differential housing.



GC031A

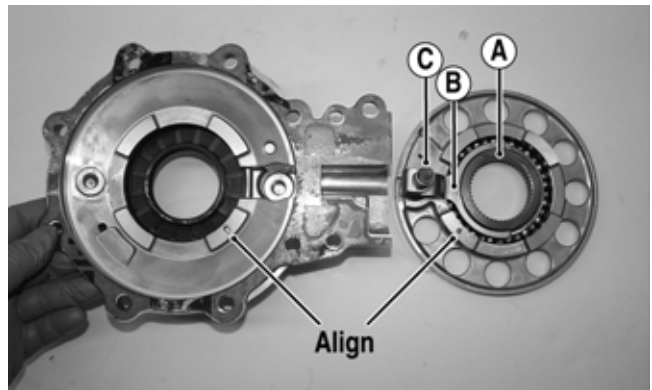

PK223A



PK222

2. Place the selected (end-play) shim, chamfered side toward the gear (if applicable), onto the cover side of the ring gear.



PK224

4. Verify the bearing flange is properly aligned with the different cover and fully seated. With the two dowel pins in place on the differential housing, place a new gasket into position.

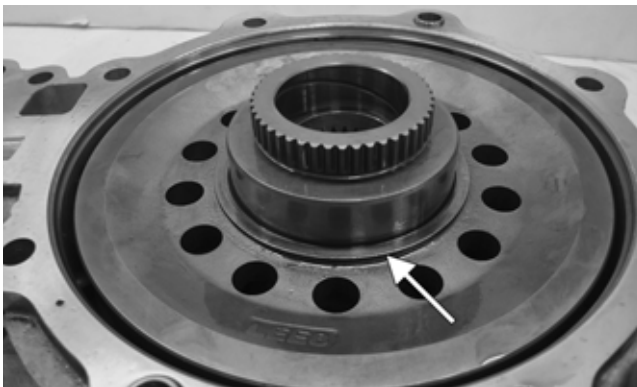

PK208A

■NOTE: The spider and ring gear assembly must be replaced as a complete unit.

3. Place the differential lock coupler (A) into the fork (B); then install the differential lock fork shaft (C) into the bearing flange. Ensure the alignment pin found in the bearing flange aligns with the recess in the differential cover. Place the cover onto the bearing flange.

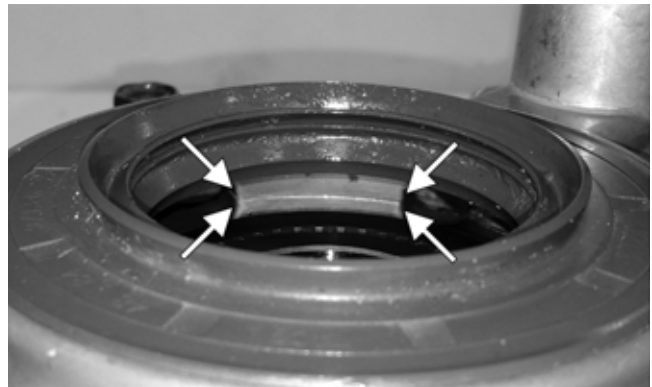

PK225A

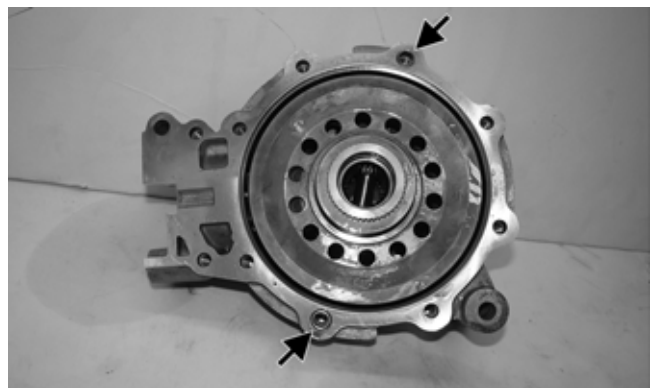

PK222A

5. Keeping the bearing flange pressed against the cover, install the assembly onto the differential housing. While this is being performed, align the internal splines of the differential lock coupler to the external splines of the housing. Secure the cover to the housing with existing cap screws. Tighten evenly to 16.5 ft-lb (22.4 N-m).

■NOTE: Place the differential ID tag in the position shown.

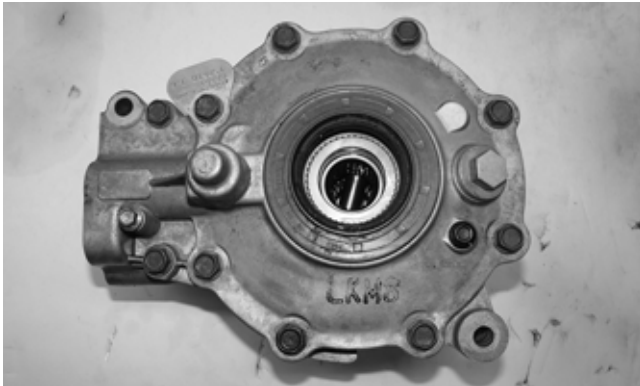

PK226

6. Install the two shift fork shafts with spring and 2WD/4WD coupler into the housing. Grease the splines; then engage the splines of the coupler to the splines of the pinion shaft.



PK227

7. With the dowel pin (A) in place, install a new gasket. Place the input shaft housing with bracket onto the differential housing. Tighten the cap screws to 16.5 ft-lb (22.4 N-m).

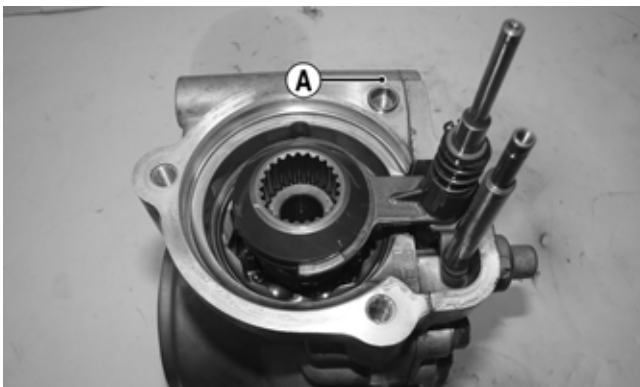

PK039A

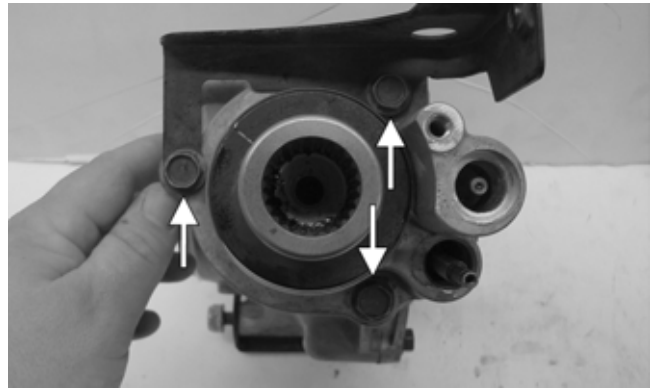

PK038A

8. Slide the return spring (A) onto the differential lock push rod (B). Place the cupped side of the retaining cap (C) onto the return spring (A); then secure with a new circlip (D).

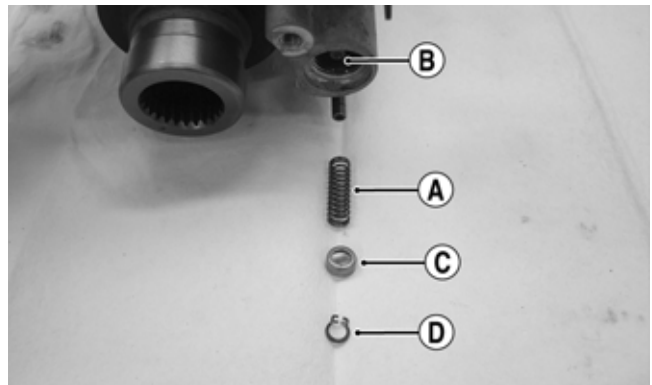

PK037A

9. Secure the slotted plug with O-ring into the housing. Install the actuator (see Front Drive Actuator/Installing steps 1-5 in this section).

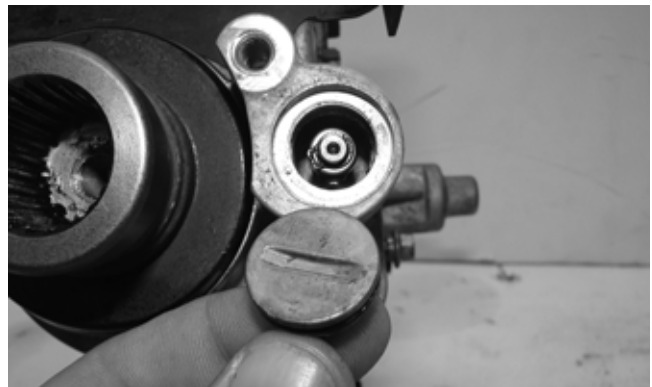

PK036

Removing/Installing Axle Seal

■NOTE: This procedure can be performed on a rear gear case.

1. Remove the seal using a seal removal tool.

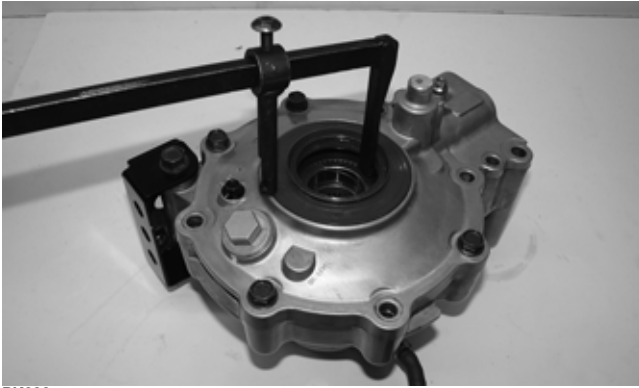

PK228

■NOTE: Prior to installing the seal, apply High-Performance #2 Molybdenum Disulfide grease to the seal outside diameter.

- Using Gear Case Seal Installer Tool, evenly press the seal into the cover bore until properly seated.

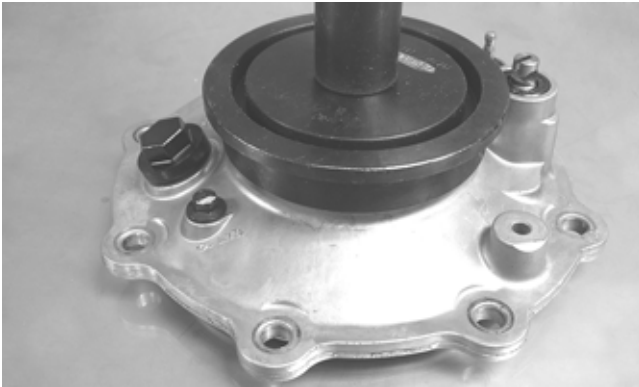

CF278

CAUTION

Make sure the tool is free of nicks or sharp edges or damage to the seal may occur.

- Repeat steps 1-2 for the opposite side.

INSTALLING DIFFERENTIAL

- Place the bracket onto the differential with the weld-nuts located toward the bottom of the bracket. Insert the bolt through the right side; then loosely install a new lock nut.



PK232

- Grease the input shaft and front propeller shaft splines. Insert the tension spring (A) into the propeller shaft. Place the differential assembly into position in the frame engaging the front propeller shaft; then install the top mounting cap screw and new lock nut. Do not tighten at this time. Slide the propeller shaft boot with the two spring clamps over the input shaft coupling.

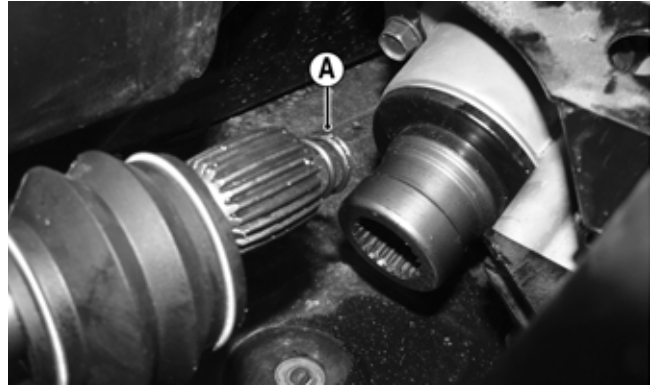

PK229A

- Install the two cap screws securing the differential bracket to the bottom of the frame and tighten to secure. Tighten both upper and lower through bolt lock nuts to 29 ft-lb (39.4 N-m).

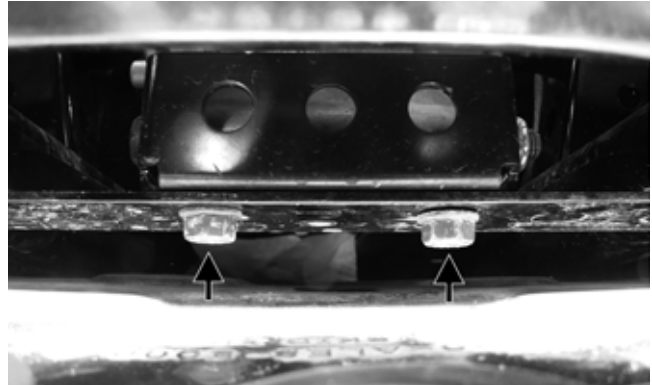

PK230A

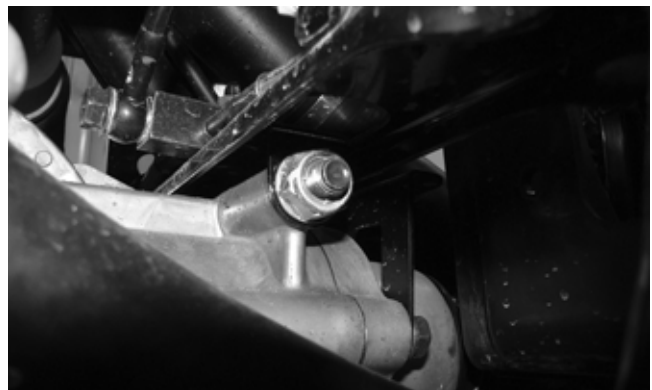

PK231

- Pour 250 mL (8.45 fl oz) of SAE 80W-90 hypoid lubricant into the differential and install the fill plug. Tighten to 16 ft-lb (21.8 N-m). Install the differential bladder with hose and secure with the clamps.
- Install the front axles.



PK233

6. Install the knuckle assemblies onto the axles and ball joints; then secure with four cap screws taking care not to damage the threads when installing. Tighten to 34 ft-lb (46.2 N-m).

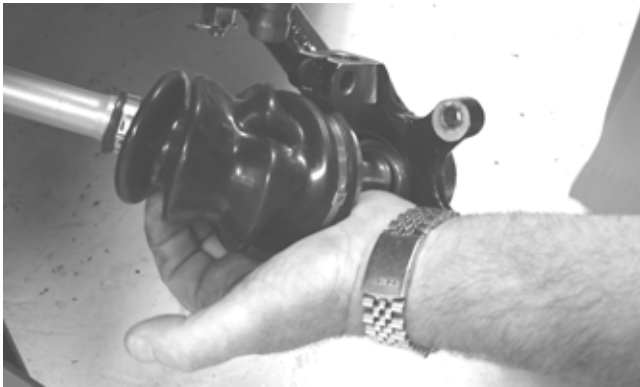

PR201

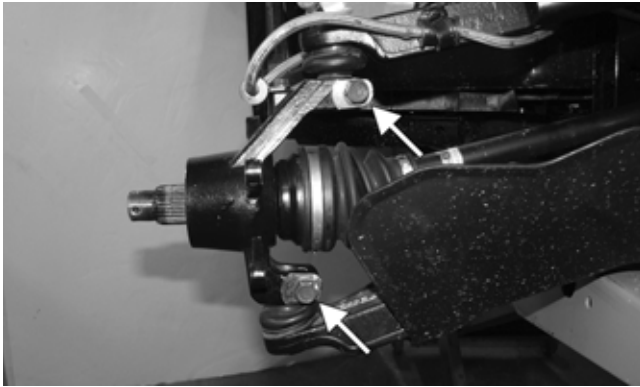

PK234A

7. Connect the front drive actuator connector to the main harness; then secure the wires to the frame with nylon ties. Install the center floorboard kick panel.
8. Apply a light coat of multi-purpose grease to the hub splines; then install the hubs (see Hub in this section).
9. Install the wheels and, using a crisscross pattern, tighten the wheel nuts in 20 ft-lb (27.2 N-m) increments to a final torque of 45 ft-lb (61.2 N-m) (steel wheel), 60 ft-lb (81.6 N-m) (aluminum wheel w/ black nuts), or 80 ft-lb (108.8 N-m) (aluminum wheel w/chrome nuts).
10. Install the front belly panel.

Drive Axles

REMOVING REAR DRIVE AXLE

1. Lift the vehicle using a suitable lift to elevate the wheels off the ground. Remove the hubs (see Hub in this section).
2. Remove the cap screw and lock nut securing the knuckle to the upper A-arm. Discard the lock nut.



PK284

3. Use a tie-down to hold the upper A-arm up and out of the way. While holding the drive axle stationary, pull the top of the knuckle out and down until it is free of the drive axle. Account for the two dust seals (A).

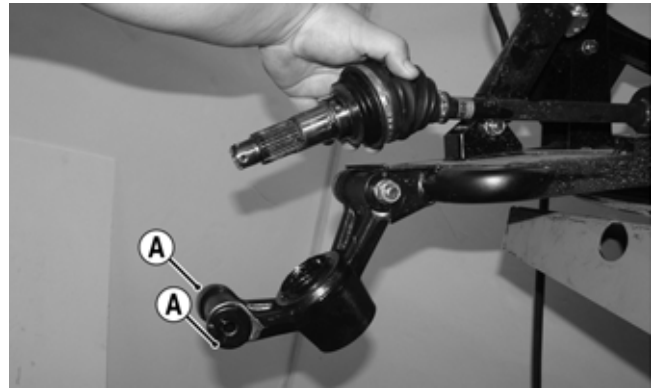

PK314A

4. Place a drain pan under the vehicle to contain any oil leakage; then pushing the axle shaft in, using a quick outward pulling action, pull the axle assembly from the gear case.

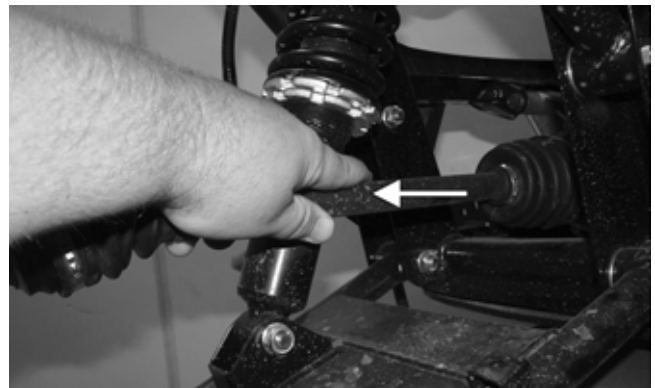

PK315A

REMOVING FRONT DRIVE AXLE

■NOTE: For removing a front drive axle, see Front Differential in this section.

CLEANING AND INSPECTING AXLES

■NOTE: Always clean and inspect the drive axle components to determine if any service or replacement is necessary.

1. Using a clean towel, wipe away any oil or grease from the axle components.
2. Inspect boots for any tears, cracks, or deterioration.

■NOTE: If a boot is damaged in any way, it must be replaced with a boot kit.

DISASSEMBLING AXLES

■NOTE: Only the boots are serviceable on the axles; if any other component is worn or damaged, the axle must be replaced.

Outboard CV Joint

1. Using CV Boot Clamp Tool, remove and retain both clamps from the outboard CV joint for assembly purposes. Slide the boot back.



CF337

2. Using soft jaws, secure the half-shaft into a vise. Using a hammer and punch, strike the inner race in multiple positions to remove the joint from the shaft.



PK235

3. Remove the outer CV joint; then remove the boot.



PK236

ASSEMBLING AXLES

Outboard CV Joint

1. Install the outer boot with the small clamp onto the axle, making sure the ends of the clamp are positioned correctly.

■NOTE: The boot is positioned correctly when the small end of the boot seats down into the recessed groove.

2. Using the Boot Clamp Tool, secure the small clamp of the inner boot.

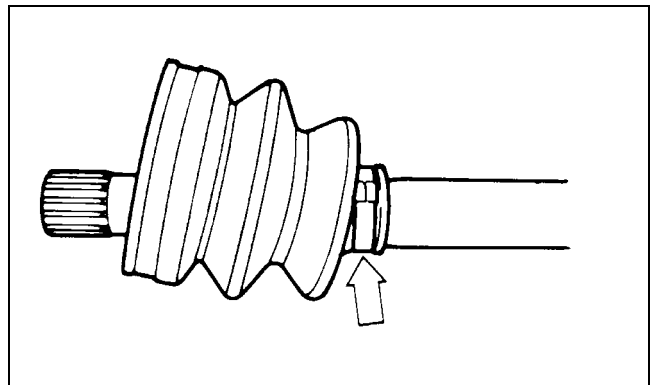

ATV-1048

3. Apply 40 grams (1/3 of contents) of grease from the pack into the bearing housing.
4. Verify the circlip is in position within the recess located at the end of the half-shaft. Engage the splines of the CV joint to the splines of the half-shaft.
5. Slide the CV joint toward the circlip, applying slight inward pressure to the CV joint toward the circlip. Using a punch or flat blade screw driver, compress the circlip into its recess. With pressure still applied to the CV joint, use a plastic dead blow hammer and strike the end of the CV joint to fully seat it to the axle.

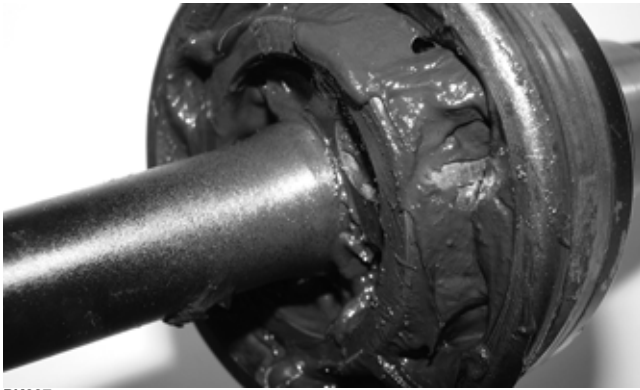

PK237

- Using the Boot Clamp Tool, install and secure the large outside diameter clamp.



PK238

Removing Inboard CV Joint

- Using the Boot Clamp Tool, remove both clamps from the inboard CV joint. Slide the boot away from the joint.

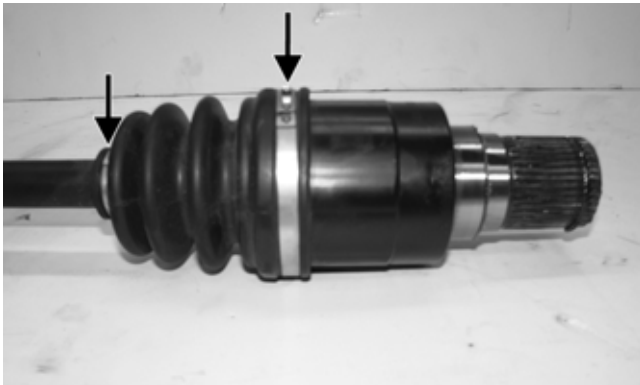

PK239A

- Using a pick or small flat blade screw driver, remove the circlip stop ring (A) from the CV housing. Remove the housing.



PK240A



PK241

- Note the orientation of the CV joint to the half-shaft. Remove the snap ring securing the joint to the shaft. Remove the CV joint; then remove the boot.

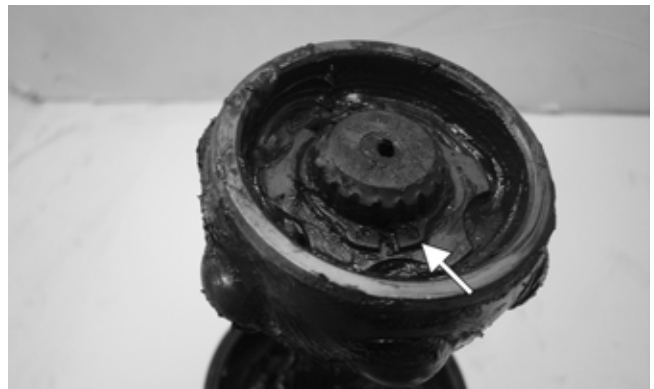

PK242A

Installing Inboard CV Joint

- Place the small diameter clamp and new boot onto the axle.
- Install the CV joint onto the axle with the large tapered side located toward the end of the axle. Position a new snap ring so the sharp edged side faces toward the end of the axle.

■NOTE: In the inboard boot, use the final 80 grams (2/3 of contents) of grease from the pack in the bearing housing.

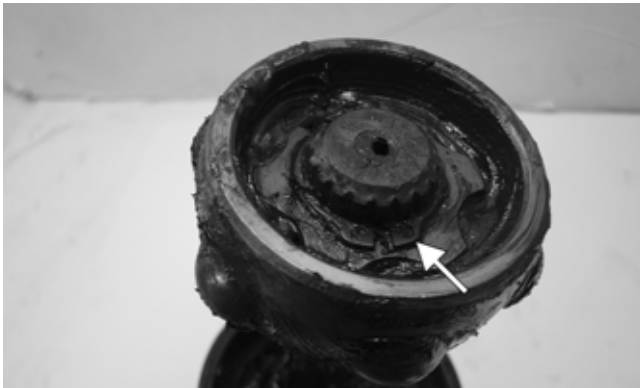

PK242A

- Slide the CV housing onto the CV joint; then install a new circlip stop ring (A). Slide the new boot into position; then using the boot clamp tool, secure the two clamps.



PK240A

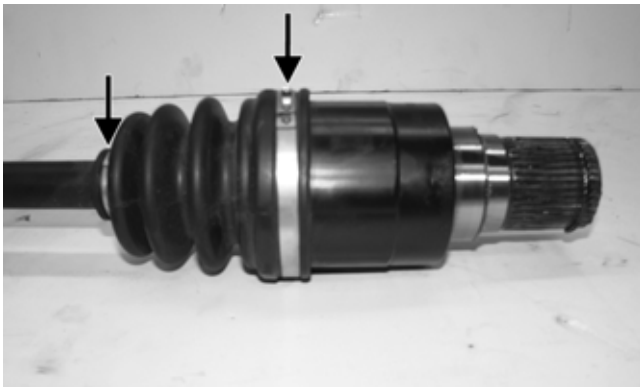

PK239A

■NOTE: Find the half-way point of the inboard CV joint stroke; then secure the clamps. As this is the plunging CV joint.

INSTALLING REAR DRIVE AXLE

- Lightly coat the splines on each side of the axle using anti-seize. Verify the circlip is installed on the inboard CV joint splines. Grasp the inboard CV joint and axle and align the splines of the CV into the ring gear housing; then slide the drive axle into place in the gear case.



PK243A

■NOTE: To ensure proper axle seating, give it a light pull; the axle should remain “clipped” in place.

- Swing the knuckle up and onto the drive axle; then place the knuckle into place in the upper A-arm. Verify both dust seals are installed to each side of the knuckle. Secure the knuckle to the A-arm with a cap screw and a new lock nut. Tighten to 35 ft-lb (47.6 N-m).
- Install the hubs (see Hub in this section).
- Install the wheels and using a crisscross pattern, tighten the wheel nuts in 20 ft-lb (27.2 N-m) increments to a final torque of 45 ft-lb (61.2 N-m) (steel wheel), 60 ft-lb (81.6 N-m) (aluminum wheel w/black nuts), or 80 ft-lb (108.8 N-m) (aluminum wheel w/chrome nuts).
- Remove the vehicle from the lift. Check the rear gear case lubricant level and add lubricant as necessary.

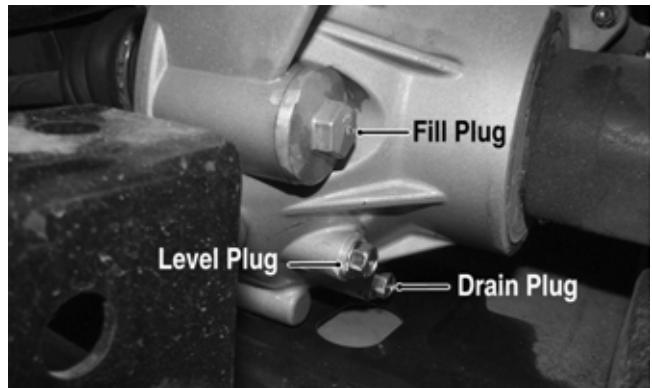

PK028A

INSTALLING FRONT DRIVE AXLE

- Lightly coat the splines on each side of the axle with anti-seize. Verify the circlip is installed on the inboard side CV joint splines. Grasp the inboard CV joint and axle and align the splines of the CV into the ring gear housing; then position the drive axle in the gear case and steering knuckle. Insert the ball joints into the steering knuckles. Secure with cap screws tightened to 34 ft-lb (46.2 N-m).
- Install the hubs (see Hub in this section).
- Install the wheels and using a crisscross pattern, tighten the wheel nuts in 20 ft-lb (27.2 N-m) increments to a final torque of 45 ft-lb (61.2 N-m) (steel wheel), 60 ft-lb (81.6 N-m) (aluminum wheel w/black nuts), or 80 ft-lb (108.8 N-m) (aluminum wheel w/chrome nuts).

- Remove the vehicle from the lift.
- Check the front differential lubricant level and add lubricant as necessary.

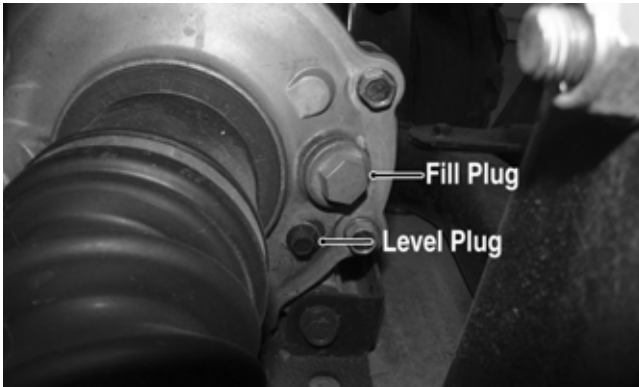

PK027A

Rear Gear Case

REMOVING

- Drain the lubricant from the rear gear case; then remove both rear drive axles (see Drive Axles).
- Remove the two patch lock cap screws securing the rear caliper to the gear case. Discard the cap screws.

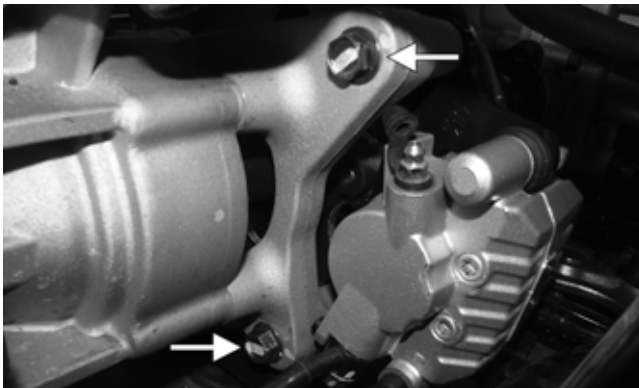

PK266A

- Remove the bladder hose from the top of the fitting on the gear case; then remove the two lock nuts and through bolts securing the gear case to the frame.

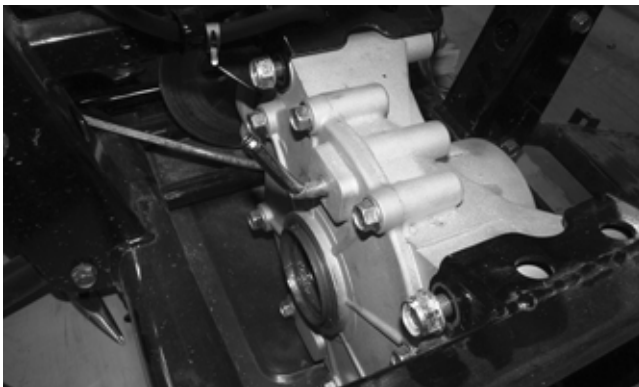

PK265

- Pull the rear propeller shaft boots away from the input shaft and rear engine flange. Holding the propeller shaft in place, disengage the gear case from the propeller shaft moving it toward the rear. Account for the tension spring in the input shaft and boot spring clamps.



PK264

- Tilt the gear case on its right side; then move it forward through the frame. Remove the gear case from the right side of the frame.

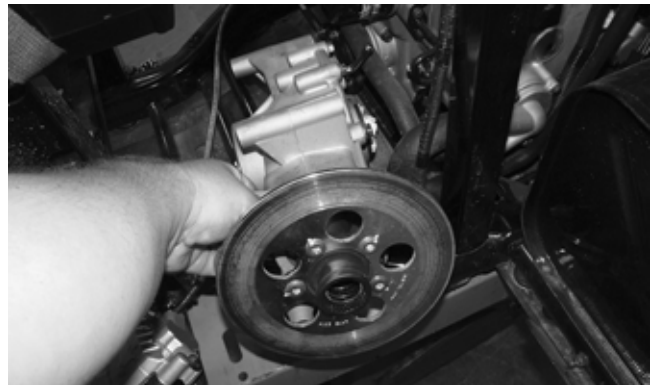

PK267

⚠ AT THIS POINT

For servicing the input shaft, pinion gear, needle bearing, ring gear, and axle seals, see Front Differential in this section.

DISASSEMBLING

- Remove the input shaft spring (A); then remove the cap screw and washer securing the input shaft to the pinion gear shaft. Remove the input shaft assembly.



PK244

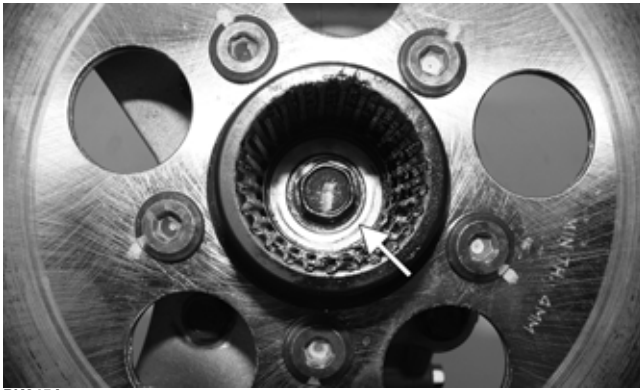

PK245A

2. Remove the four cap screws securing the rear caliper mount to the gear case. Record the locations of the two different-length cap screws, which require patch-lock (A). Account for four crush washers.

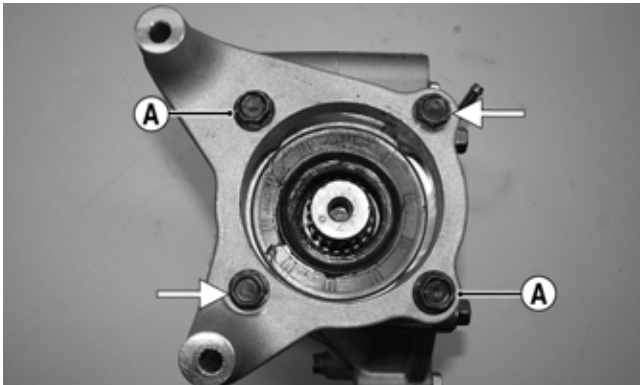

PK246A

3. Remove the bracket from the gear case. Account for the two dowel pins.



PK247

4. Place the gear case on its side; then remove the cap screws securing the housing cover to the housing. If necessary, use the pry point to aid in removal of the cover. Account for the cover side shim.

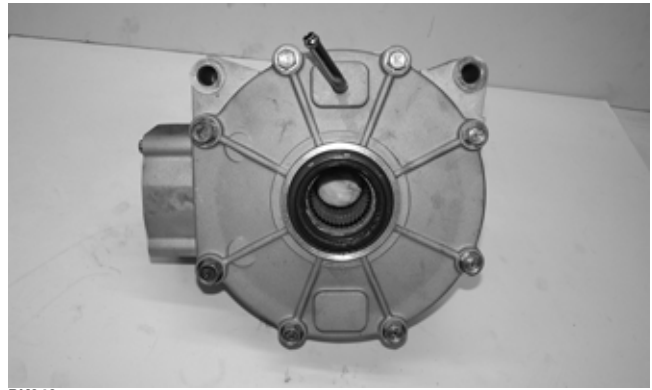

PK248

5. Remove the ring gear from the housing. Account for the housing side shim.

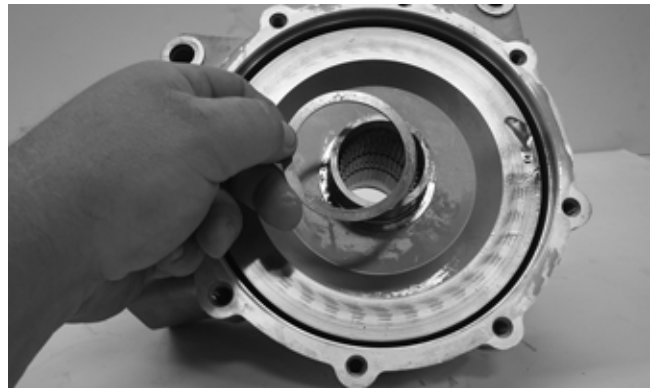

PK249

6. Remove the pinion shaft seal; then, using the Pinion Gear Lock Collar Socket, remove the lock collar.

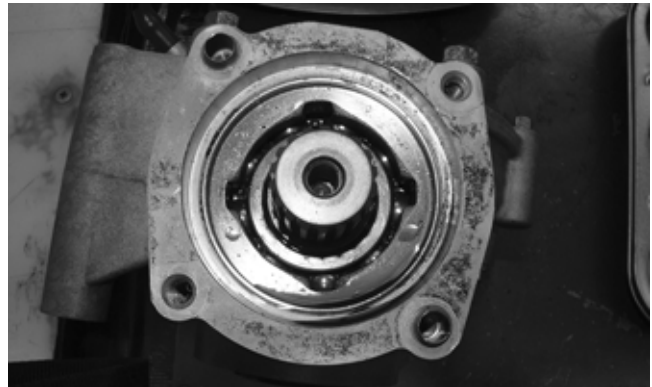

PK251



PK250

CAUTION

Protective equipment should be worn, as severe injury or burns could result.

7. Using a propane torch, heat the gear case to approximately 200° F (93° C). Carefully using the Pinion Gear/Shaft Removal tool, remove the pinion gear.



PK252

8. Remove the snap ring securing the needle bearing to the gear case; then, using a suitable bearing puller, remove the bearing.



PK253

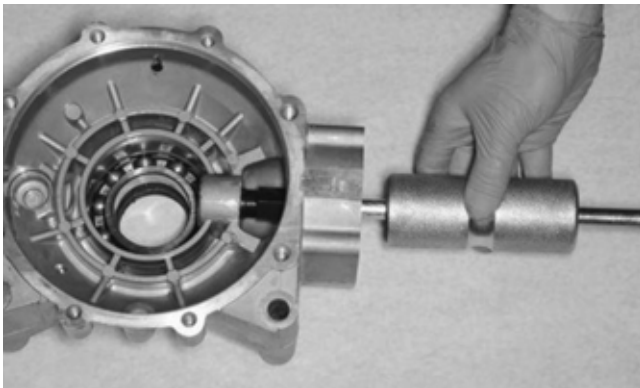

PK254

9. Place the pinion gear assembly into a bearing puller; then using a press, separate the bearing from the pinion. Account for the shim, as it is required to be re-used upon assembly.

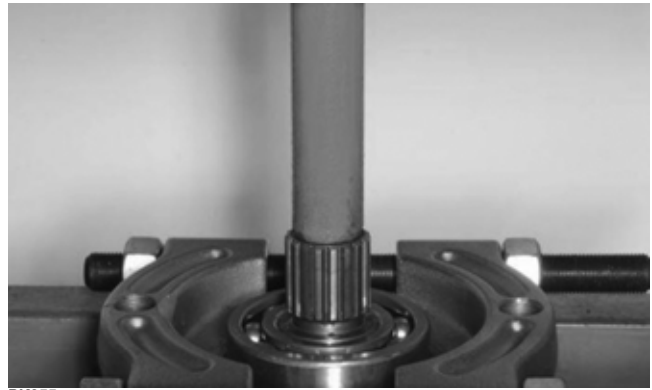

PK255

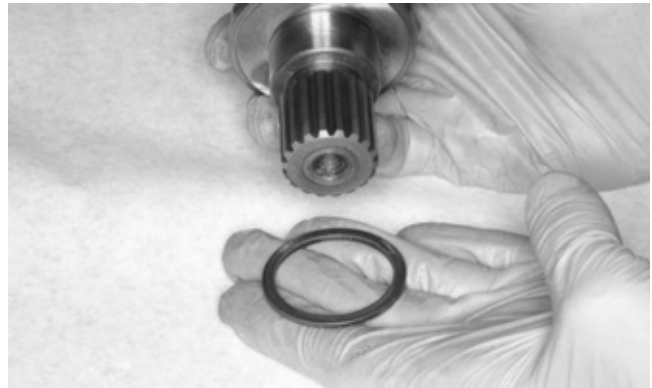

PK256

10. To replace the cover bearing, use a suitable seal puller to remove the seal; then drive the bearing out from the outside of the cover.

11. To replace the case side bearing, use a suitable seal puller to remove the seal; then remove the snap ring securing the case side bearing.



PK257

12. Using a bearing driver, remove the case side bearing from the inside of the case.

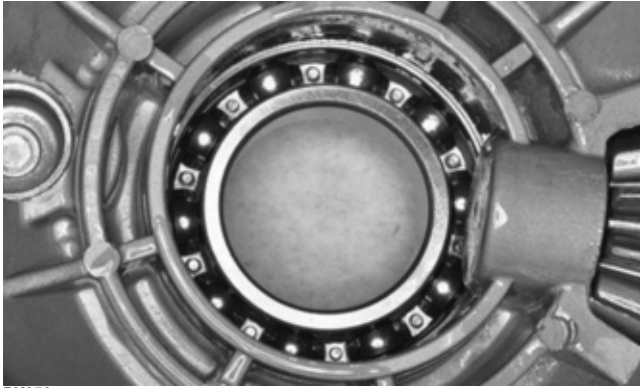

PK258

CLEANING AND INSPECTING

1. Wash all parts in parts cleaning solvent and dry with compressed air.

⚠ WARNING

Always wear safety glasses when working with compressed air.

2. Clean all gasket material and sealant from mating surfaces.
3. Inspect bearings, shafts, and housing for excessive wear, cracks, or discoloration.

ASSEMBLING

1. Using a bearing driver adapter the same size as the outer race of the case side bearing, drive the bearing into place, then secure with a new snap ring. Lightly grease a new seal; then install.



PK257

2. From the inside of the gear case cover, use a bearing driver adapter the same size as the outside race of the bearing and install. Lightly grease a new seal and install.

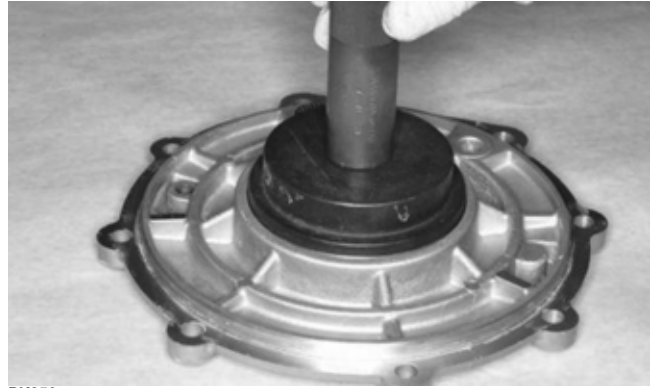

PK259

3. Place the pinion gear shim into position; then, using a set of press blocks, press the pinion gear into a new bearing.

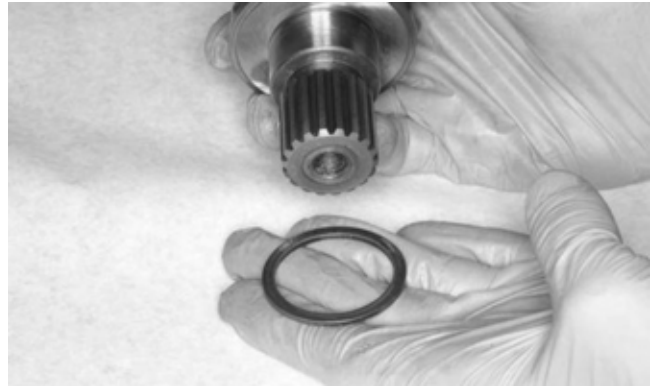

PK256



PK260

4. Drive a new pinion gear needle bearing into the case using a bearing driver the same size as the outer race of the bearing; then secure the bearing with the snap ring.

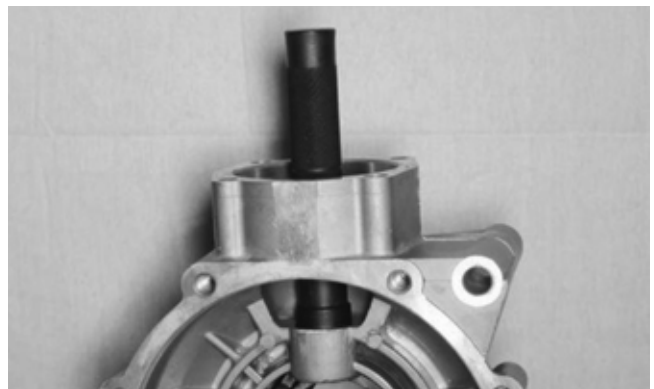

PK261

- Using soft jaws, secure the gear case into a vise. Using a propane torch, heat the gear case to approximately 200° F (93° C); then carefully install the pinion gear assembly into the case. Install the lock collar to secure the pinion into the case. Using the Pinion Gear Lock Collar Socket, tighten to 125 ft-lb (169.5 N-m).

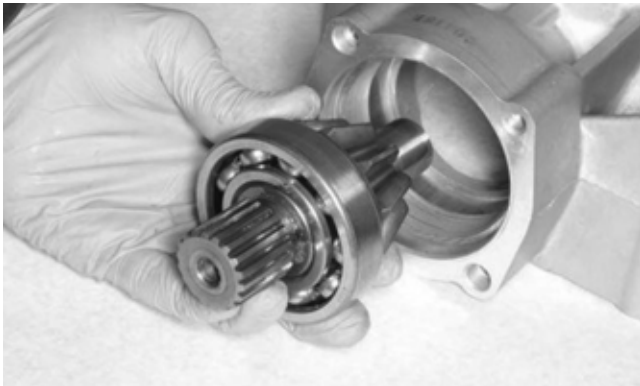

PK252

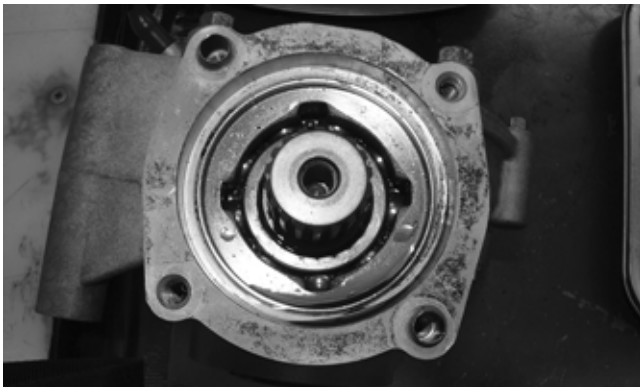

PK251

- Allow the gear case to cool; then lightly grease and install a new pinion shaft seal. If Backlash and Gear Tooth Contact are within specification, proceed to step 7.



PK247

Checking Backlash

- Place the original case side shim (A) onto the ring gear housing; then place the ring gear into the gear case. Place the cover side shim (B) onto the ring gear housing; then temporarily install and secure the cover to the gear case.

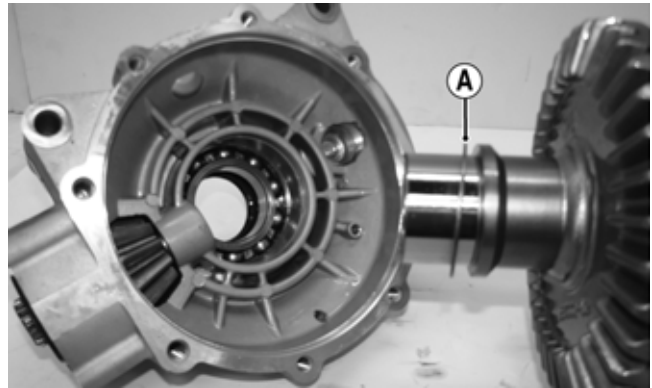

PK262A

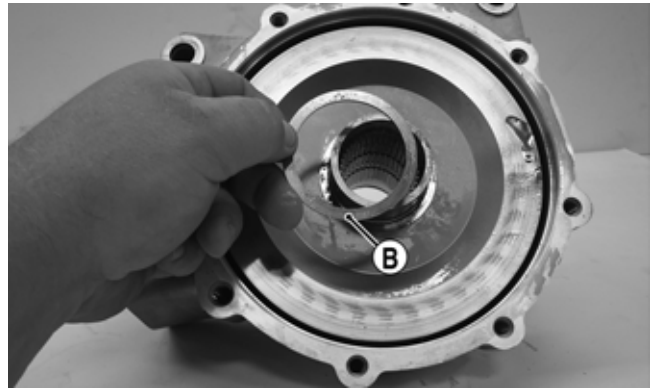

PK249A

- While holding the pinion gear shaft, place a horizontal type dial gauge through the filler hole and against the ring gear. Rotate the pinion gear shaft back and forth; then record the reading from the dial gauge. Check at three different locations spaced around the ring gear. Standard specification is 0.05-0.25 mm (0.002-0.010 in.).
- If the measurement is out of adjustment, the shims must be replaced. Refer to the included chart for instructions regarding replacement of the case side (right side) shims. If the case side shims are replaced, the cover side shims must also be replaced to compensate for the backlash adjustment.

Backlash	Right Shim Adjustment
Under 0.05 mm (0.0020 in.)	Increase shim thickness
Over 0.25 mm (0.010 in.)	Decrease shim thickness

Gear Tooth Contact

- After backlash has been set, the gear tooth contact must be confirmed.
- Remove the ring gear housing. Thoroughly clean the gear teeth of the ring and pinion gears. Apply machinist's dye to several teeth of the pinion gear. Temporarily install the ring gear housing with shims used when setting backlash. Install the cover.
- Rotate the pinion gear shaft back and forth, so the dye-coated gear teeth contact each other.
- The dye should show that the contact area of the two sets of teeth are centered. If contact is too high or too low on the teeth, the pinion gear shaft shim must be exchanged to achieve proper tooth contact while maintaining correct backlash.

7. Place the correctly sized case side shim onto the ring gear; then install into the gear case. Place the cover side shim onto the ring gear.

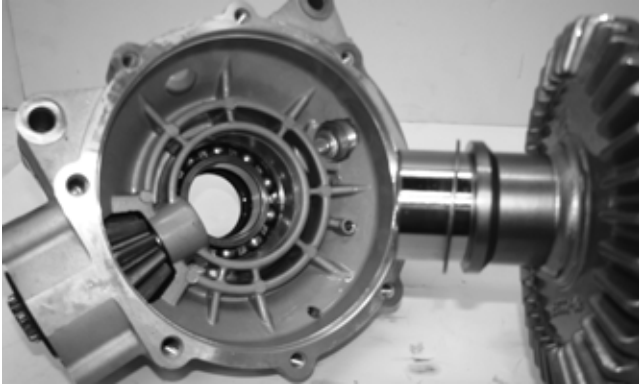

PK262

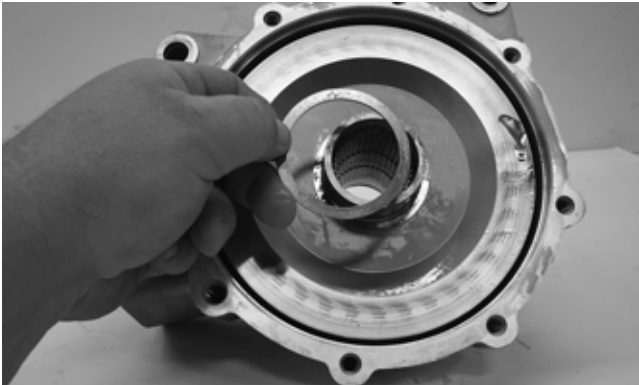

PK249

8. Thoroughly clean the matting surface of the case and cover. Apply a suitable sealant to the surface; then install the cover. Using a criss-cross pattern, tighten the cap screws to 16.5 ft-lb (22.4 N-m).
9. Place the two dowel pins into position; then install the brake caliper mount. Using two new patch-lock caps screws, tighten all four cap screws with crush washers to 19 ft-lb (25.8 N-m).



PK246

10. Secure the input shaft to the pinion gear shaft using the cap screw and washer. Tighten to 32 ft-lb (43.5 N-m).

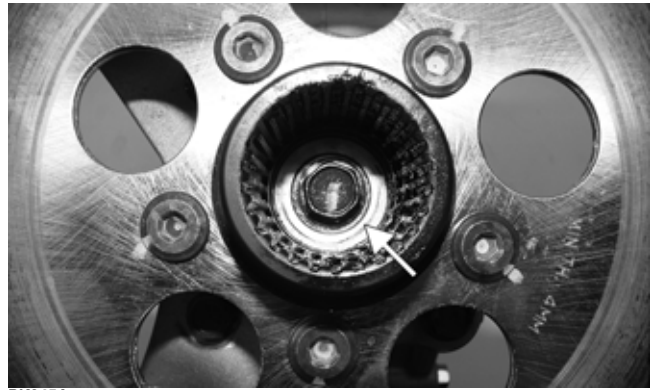

PK245A

INSTALLING

1. Place the spring into the input shaft; then position the gear case into position below the frame mounts.



PK244

2. Lightly grease both splined ends of the rear propeller shaft engaging the splines to the rear engine flange. Slide the differential forward to engage the splines of the rear propeller shaft.

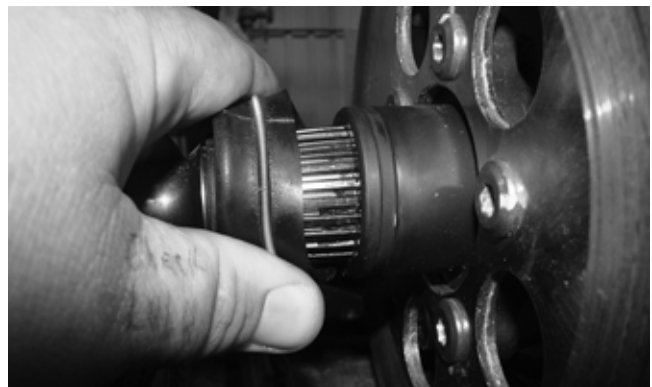

PK264

3. Lift the differential up into the frame mounts; then insert the through bolts. Using new lock nuts, tighten to 39 ft-lb (53 N-m). Place the bladder hose onto the ventilation fitting located on the top left of the gear case.

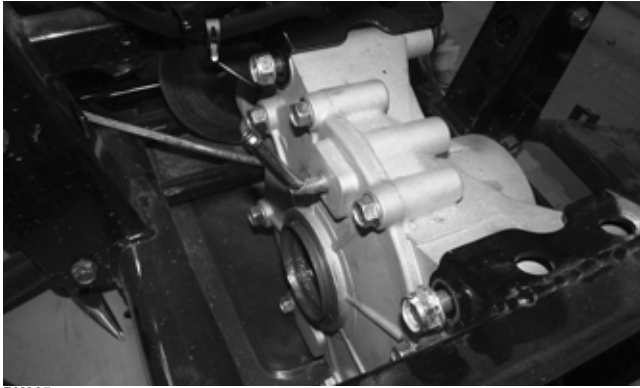

PK265

- Using new patch lock cap screws, install and secure the rear brake caliper to the mount and tighten the screws to 19 ft-lb (25.8 N-m). Install the drive axles (see Drive Axles).

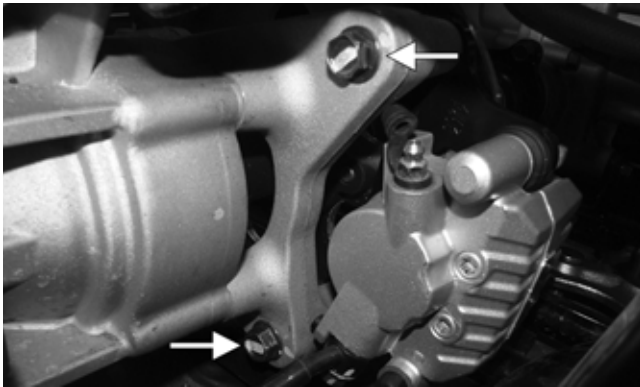

PK266A

- Remove the fill and check plugs; then add the recommended amount of gear lubricant. Secure the fill and check plugs.

Hub

REMOVING

- Secure the vehicle on a support stand to elevate the wheel; then remove the wheel(s).

■NOTE: The jack stands should be placed under the main frame to avoid contact with front suspension components.

■NOTE: Removing or tightening of the hub nuts requires the axles be locked. To lock the rear axle, place the transmission in park. To lock the front axle, turn the ignition switch to ON and select LOCK on the drive select switch; then place the transmission in park and turn the ignition switch to OFF.

WARNING

Make sure the vehicle is solidly supported on the support stand to avoid injury.

- Remove the cotter pin from the axle. Discard the cotter pins.

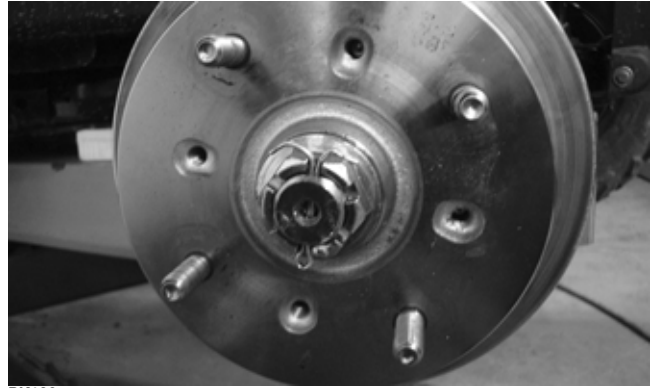

PK130

- Remove the hub nut securing the hub. Continue to step 4 to remove the front hubs.

- Remove the brake caliper(s) on the front only.

■NOTE: It is not necessary to remove the brake hoses from the calipers for this procedure.

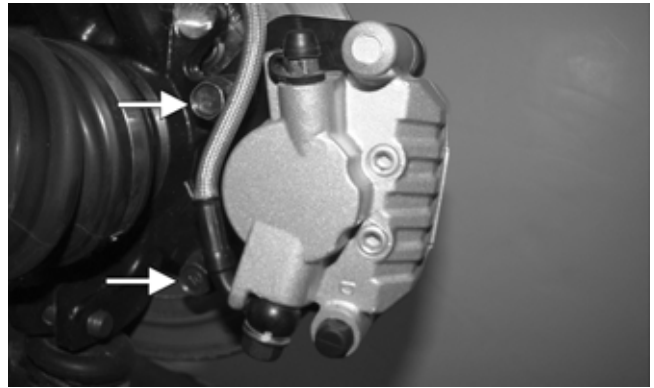

PK106B

- Remove the hub assembly.

- Remove the four cap screws (front) or five cap screws (rear) securing the brake disc to the hub (front) or input shaft (rear). Discard the bolts.

■NOTE: To replace the rear brake disc, the rear gear case must be removed (see Rear Gear Case).



PK268



PK269

CLEANING AND INSPECTING

1. Clean all hub components.
2. Inspect all threads for stripping or damage.
3. Inspect the brake disc (if applicable) for cracks or warping.
4. Inspect the hub for pits, cracks, loose studs, or spline wear.

REPLACING WHEEL STUDS

1. Secure the hub in a suitable holding fixture and remove the brake disc (if applicable).
2. Drive the damaged stud out of the hub; then place the new stud into the hub and thread on an appropriate flange nut.

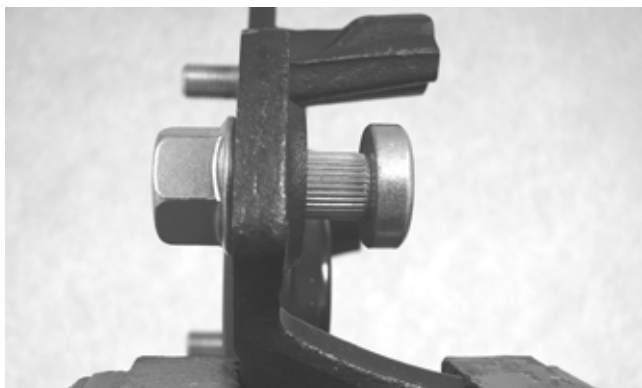

PR250

3. Using a socket and ratchet handle, tighten the nut until the stud is fully drawn into the hub.

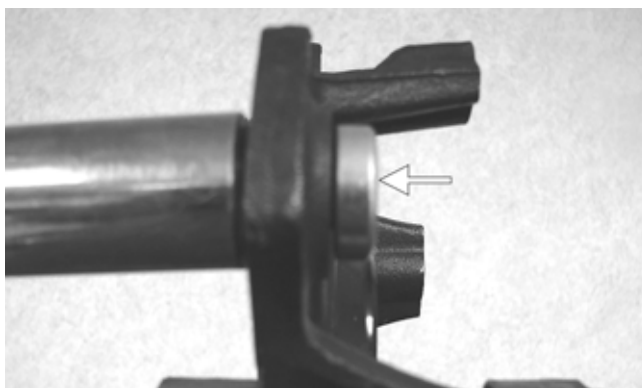

PR252A

INSTALLING

1. Secure the brake disc to the hub (front) with the four cap screws or to the rear input shaft with five cap screws coated with red Loctite #271. Tighten to 25 ft-lb (34 N-m).
2. Apply grease to the splines of the front hub. If installing the rear brake disc, at this point reinstall the rear gear case (see INSTALLING).



PK268A

■NOTE: The remaining instructions are for final installation of the front hubs.

3. Install the hub assembly onto the axle; then place the transmission in park.

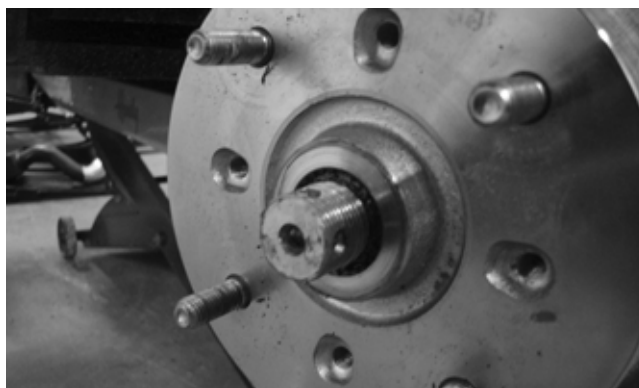

PK128

4. Secure the hub assembly with the nut. Tighten to 200 ft-lb (271.2 N-m); then secure with a new cotter pin.

■NOTE: If the cotter pin cannot be inserted due to misalignment of the hole in the axle and the slots in the nut, tighten the nut until properly aligned.



PK130

- Secure the brake calipers to the knuckle with two new “patch-lock” cap screws tightened to 19 ft-lb (25.8 N-m).

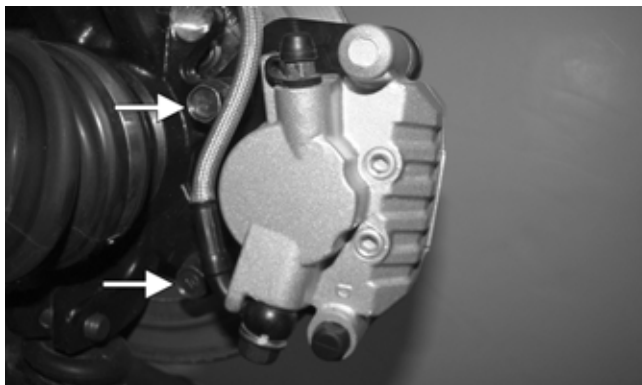

PK106B

- Install the wheels and using a crisscross pattern, tighten the wheel nuts in 20 ft-lb (27.2 N-m) increments to a final torque of 45 ft-lb (61.2 N-m) (steel wheel), 60 ft-lb (81.6 N-m) (aluminum wheel w/black nuts), or 80 ft-lb (108.8 N-m) (aluminum wheel w/chrome nuts).
- Remove the vehicle from the support stand.

Hydraulic Brake Caliper

⚠ WARNING

The manufacturer recommends only authorized ROV dealers perform hydraulic brake service. Failure to properly repair brake systems can result in loss of control causing severe injury or death.

REMOVING/DISASSEMBLING

- Secure the vehicle on a support stand to elevate the wheel; then remove the wheel.

⚠ WARNING

Make sure the vehicle is solidly supported on the support stand to avoid injury.

⚠ WARNING

Never let brake fluid contact the eyes. Damage to the eyes will occur. Always wear appropriate protective safety goggles and latex gloves when handling brake fluid.

- Remove the rubber plug covering the bleed screw; then attach a drain hose to the bleed screw. Loosen the bleed screw; then drain the brake fluid from the caliper, hose, and master cylinder through the bleed screw by pumping the brake pedal.

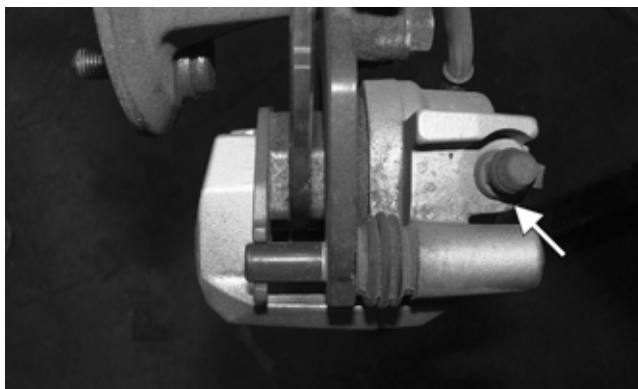

PK004B

CAUTION

Brake fluid is highly corrosive. Do not spill brake fluid on any surface of the vehicle and do not reuse brake fluid.

■ **NOTE:** Whenever brake components are removed, disassembled, or repaired where brake fluid is exposed to air, drain all fluid and replace with new DOT 4 brake fluid from an unopened container. Brake fluid readily absorbs moisture from the air significantly lowering the boiling point. This increases the chance of vapor lock reducing braking power and increasing stopping distance.

- Remove the brake hose (discard the crush washers) from the caliper and close the bleed screw; then remove the caliper.
- Remove the brake pad pins.

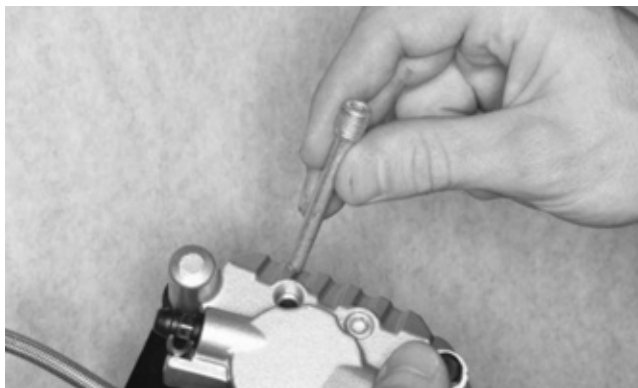

PK270

- Compress the caliper holder against the caliper and remove the outer brake pad; then remove the inner brake pad.

■ **NOTE:** If brake pads are to be returned to service, do not allow brake fluid to contaminate them.



PK271



PK272

6. Remove the caliper holder from the caliper.

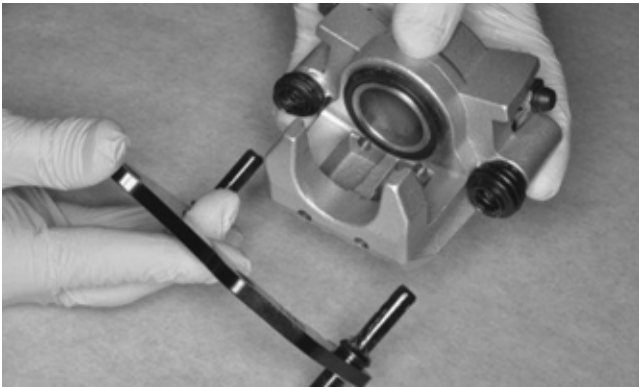

PK273

7. Cover the piston end of the housing with a shop towel; then keeping fingers clear of piston travel. Apply compressed air to the fluid port to blow the piston free of the housing. Account for the dust and piston seals.

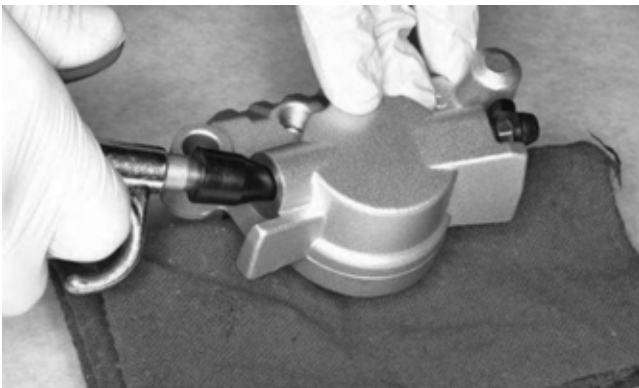

PK274

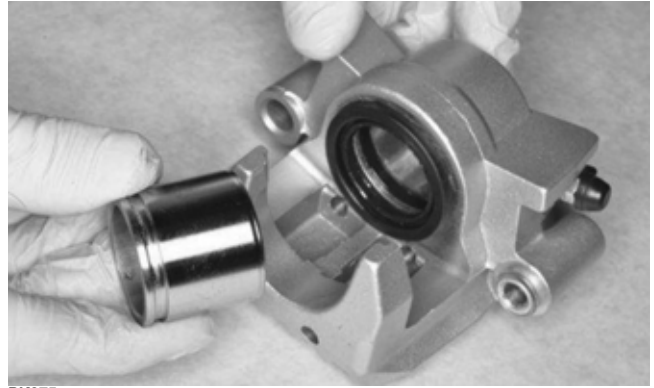

PK275

⚠ WARNING

Make sure to hold the towel firmly in place or the piston could be ejected from the housing causing injury.

- Using an appropriate seal removal tool, carefully remove the seals from the brake caliper housing. Discard all seals, O-rings, and crush washers.

CLEANING AND INSPECTING

- Clean all caliper components (except the brake pads) with DOT 4 brake fluid. Do not wipe dry.
- Inspect the brake pads for damage and excessive wear.

■ **NOTE:** For measuring brake pads, see **Periodic Maintenance/Tune-Up - Hydraulic Brake System**.

- Inspect the brake caliper housings for scoring in the piston bores, chipped seal ring grooves, or signs of corrosion or discoloration.
- Inspect the piston surface for scoring, discoloration, or evidence of binding or galling.
- Inspect the caliper holder for wear or bending.

ASSEMBLING/INSTALLING

- Install the new piston seal (A) into the brake caliper housing and apply a liberal amount of DOT 4 brake fluid to the cylinder bore of the housing, seals, and brake piston. Place the new dust seal onto the piston (B).

CAUTION

Make sure the seals are properly in place and did not twist or roll during installation.

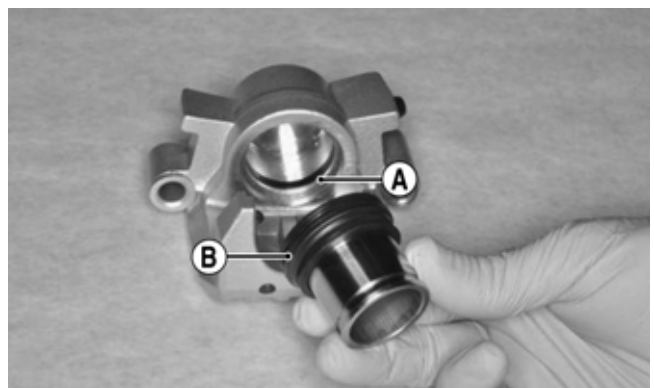

PK276A

2. Press the piston into the caliper housing using hand pressure only. Completely seat the piston and dust seal; then wipe off any excessive brake fluid.



PK277

3. Apply high-temperature silicone grease to the inside of the caliper holder bores, O-rings, and boots.
4. Install the caliper onto the caliper holder making sure the caliper and holder are correctly oriented.

■NOTE: It is very important to apply silicone grease to the O-rings, boots, and caliper bores prior to assembly.

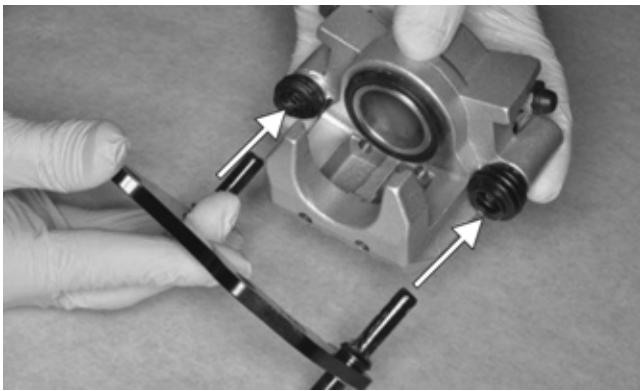

PK273A

5. Making sure brake fluid does not contact the brake pads, compress the caliper holder toward the caliper and install the inner brake pad; then install the outer pad.

CAUTION

If brake pads become contaminated with brake fluid, they must be thoroughly cleaned with brake cleaning solvent or replaced with new pads. Failure to do so will result in reduced braking and premature brake pad failure.



PK271

6. Secure the brake pads to the caliper with the brake pad pins. Apply blue Loctite to the threads of the pins; then tighten to 13 ft-lb (17.7 N-m).

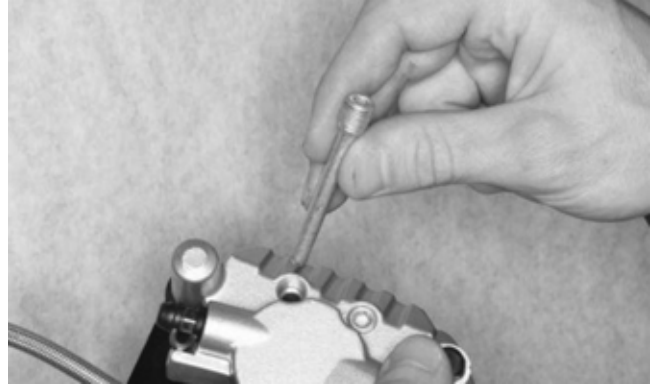

PK270

7. Place the brake caliper assembly into position and secure with new "patch-lock" cap screws. Tighten the caliper to 25 ft-lb (34 N-m).
8. Place a new crush washer on each side of the brake hose fitting and install it on the caliper. Tighten to 25 ft-lb (34 N-m).
9. Fill the reservoir; then bleed the brake system (see Periodic Maintenance/Tune-Up - Hydraulic Brake System).

WARNING

Never use brake fluid from an open container or reuse brake fluid. Moisture-contaminated brake fluid could cause vapor build-up (expansion) during hard braking resulting in greatly increased stopping distance or loss of control leading to injury or death.

10. Install the wheels and using a crisscross pattern, tighten the wheel nuts in 20 ft-lb (27.2 N-m) increments to a final torque of 45 ft-lb (61.2 N-m) (steel wheel), 60 ft-lb (81.6 N-m) (aluminum wheel w/black nuts), or 80 ft-lb (108.8 N-m) (aluminum wheel w/chrome nuts).
11. Remove the vehicle from the support stand and verify brake operation.

MASTER CYLINDER ASSEMBLY

■NOTE: The master cylinder is only serviceable as an assembly.

Removing

1. Slide a piece of flexible tubing over one of the caliper bleeder valves and direct the other end into a container. Remove the reservoir cover; then open the bleeder valve. Allow the brake fluid to drain until the reservoir is empty.

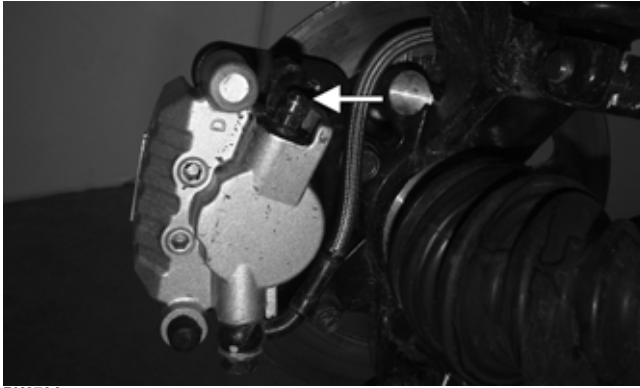

PK278A

2. Remove the front left splash panel; then remove the two banjo bolts securing the brake switch and banjo-fittings to the master cylinder.

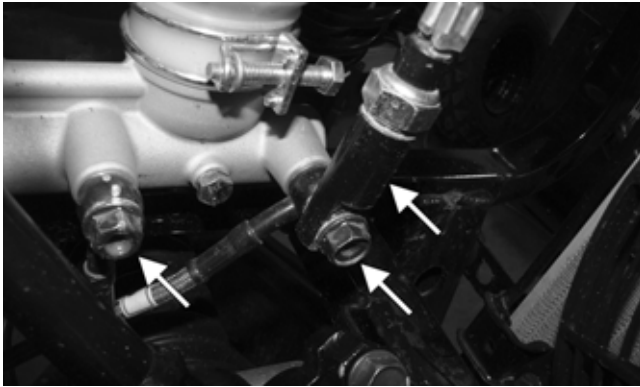

PK279A

3. Remove the lock pin (A) from the brake rod pin (B). Remove the brake rod pin from the yoke; then remove two cap screws securing the master cylinder assembly to the frame.

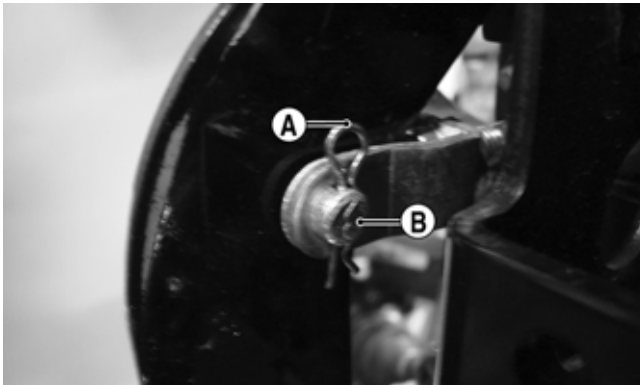

PK280A

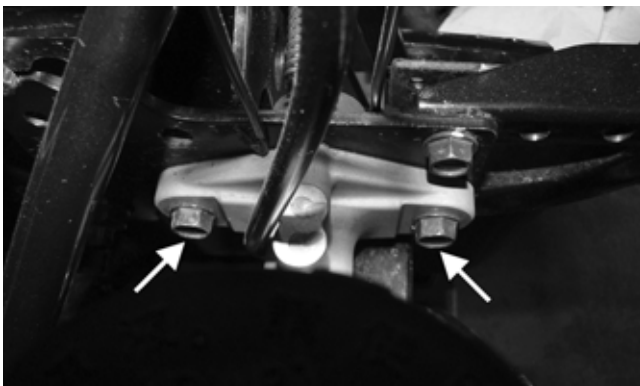

PK281A

4. Remove the master cylinder. Discard the three crush washers as new ones are required for assembly.

CAUTION

Brake fluid is highly corrosive. Do not spill brake fluid on any surface of the vehicle.

Inspecting

1. Inspect the master cylinder push rod and clevis for wear, bending, or elongation of clevis holes.
2. Inspect the push rod boot for tears or deterioration.
3. Inspect the reservoir for cracks and leakage.
4. Inspect the brake hose for cracks and deterioration and the condition of the banjo-fittings.

Installing

1. Secure the master cylinder assembly to the frame with two cap screws. Tighten to 15.6 ft-lb (21.2 N-m).
2. Using new crush washers, secure the banjo-fittings to the master cylinder with new banjo bolts and the existing brake switch. Tighten to 25 ft-lb (34 N-m).
3. Install the brake rod pin and secure with a lock pin.
4. Fill the master cylinder and bleed the brake system (see Hydraulic Brake System in the Periodic Maintenance/Tune-Up section).

Troubleshooting Drive System

Problem: Power not transmitted from engine to wheels	
Condition	Remedy
1. Rear axle shaft serration worn — broken	1. Replace shaft
Problem: Power not transmitted from engine to either front wheel	
Condition	Remedy
1. Secondary drive - driven gear teeth broken 2. Propeller shaft serration worn — broken 3. Coupling damaged 4. Coupling joint serration worn — damaged 5. Front drive — driven bevel gears broken — damaged 6. Front differential gears/pinions broken — damaged 7. Front drive actuator not operating	1. Replace gear(s) 2. Replace shaft 3. Replace coupling 4. Replace joint 5. Replace gear(s) 6. Replace gears — pinions 7. Replace fuse — drive select switch — front drive actuator

Troubleshooting Brake System

Problem: Braking poor	
Condition	Remedy
1. Pad worn 2. Brake fluid leaking 3. Master cylinder/brake cylinder seal worn	1. Replace pads 2. Repair — replace hydraulic system 3. Replace seal(s)
Problem: Brake pedal travel excessive	
Condition	Remedy
1. Brake fluid low 2. Piston seal — cup worn	1. Add fluid to proper level 2. Replace seal — cup
Problem: Brake fluid leaking	
Condition	Remedy
1. Connection fittings loose 2. Hose cracked 3. Piston seal worn	1. Tighten fittings 2. Replace hose 3. Replace seal
Problem: Brake pedal spongy	
Condition	Remedy
1. Air trapped in hydraulic system 2. Brake fluid low	1. Bleed hydraulic system 2. Add brake fluid and bleed hydraulic brake system

Suspension

The following suspension system components should be inspected periodically to ensure proper operation:

- A. Shock absorber rods bent, pitted, or damaged.
- B. Rubber damper cracked, broken, or missing.
- C. Shock absorber body damaged, punctured, or leaking.
- D. Shock absorber eyelets broken, bent, or cracked.
- E. Shock absorber eyelet bushings worn, deteriorated, cracked, or missing.
- F. Shock absorber spring broken or sagging.
- G. Sway bar mountings tight and bushings secure.

SPECIAL TOOL

A special tool must be available to the technician when performing service procedures in this section. A spanner wrench can be found in the tool kit which is located in the glove compartment. This tool is to be used when adjusting spring pre-load.

Shock Absorbers

REMOVING

1. Secure the vehicle on a support stand to elevate the wheels and to fully release the load on the suspension. Remove the wheels.

⚠ WARNING

Make sure the vehicle is solidly supported on the support stand to avoid injury.

2. Remove the upper and lower mounting cap screws and lock nuts. Discard the lock nuts. Note the mounting location of the rear upper shock mounts. This mounting location shall not be altered.

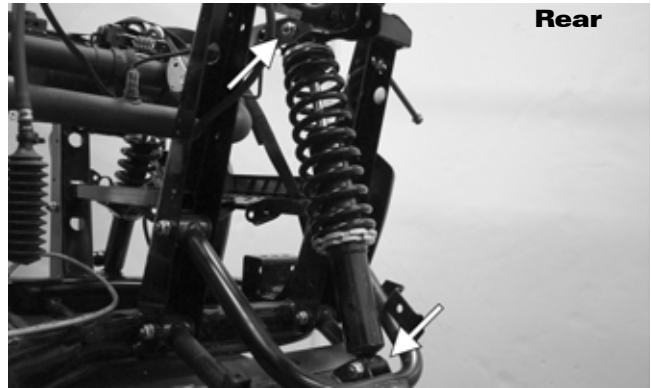
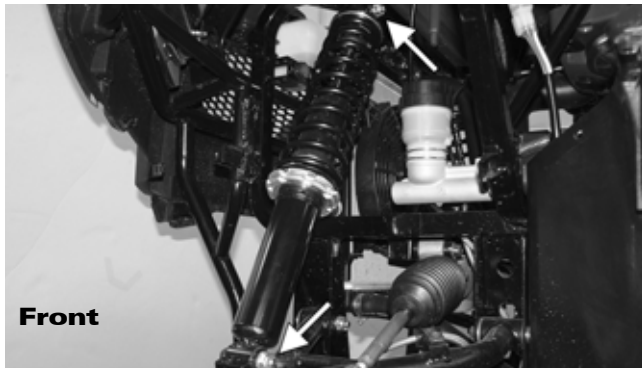

CLEANING AND INSPECTING

1. Clean all shock absorber components in parts-cleaning solvent.
2. Inspect each shock rod for nicks, pits, rust, bends, and oily residue.
3. Inspect all springs, spring retainers, shock rods, sleeves, bushings, shock bodies, and eyelets for cracks, leaks, and bends.

INSTALLING

1. Install the shock absorbers with two cap screws and new nuts. Tighten to 32 ft-lb (43.5 N-m). Install the wheels.
 2. Remove the vehicle from the support stand.
-
-

Front A-Arms

REMOVING

1. Remove the hubs (see Hub).
2. Remove the brake hose clamps from the knuckle and upper A-arm by removing the cap screws. Support the brake line and caliper using a tie-down.

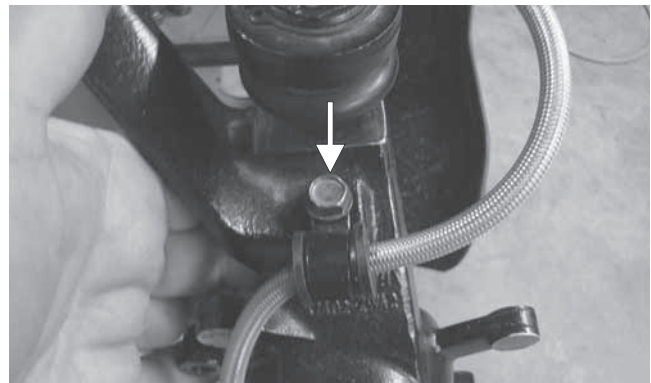



PK317

3. Remove the cotter pin and castle nut securing the tie rod end to the knuckle; then remove the tie rod end from the knuckle. Account for the washer.
4. Remove the cap screws securing the ball joints to the knuckle.

CAUTION

Support the knuckle when removing the cap screws or damage to the threads will occur.

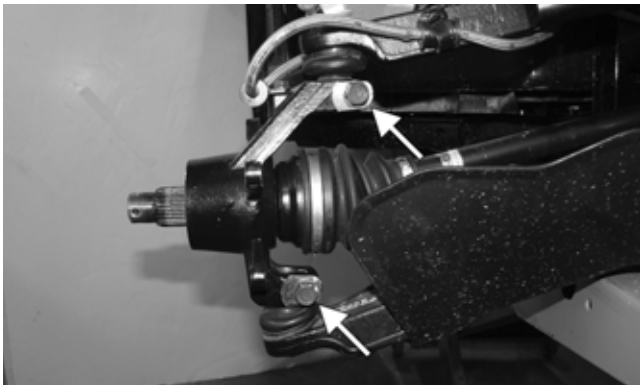

PK234A

5. Tap the ball joints out of the knuckle; then remove the knuckle.
6. Remove the lower shock absorber eyelet from the upper A-arm.



PK318

7. Remove the cap screws securing the A-arms to the frame. Account for the A-arm collars (A) and inspect the dust seals (B). By removing both seals, the bearings (C) can be pressed out for replacement.

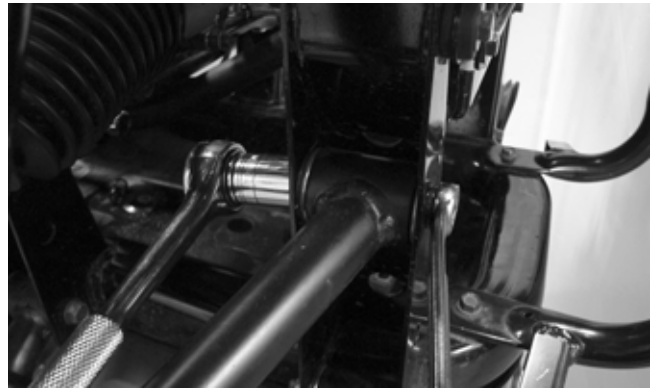

PK319

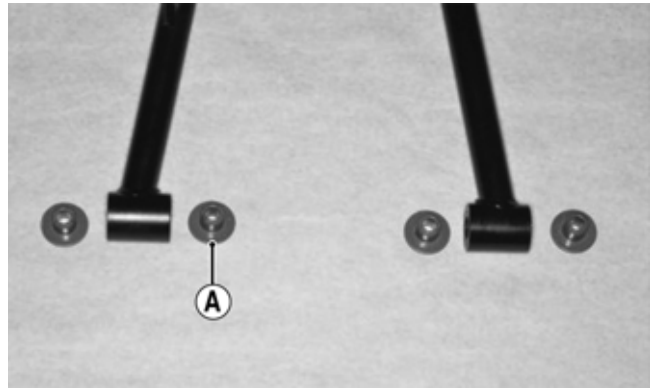

PK287A

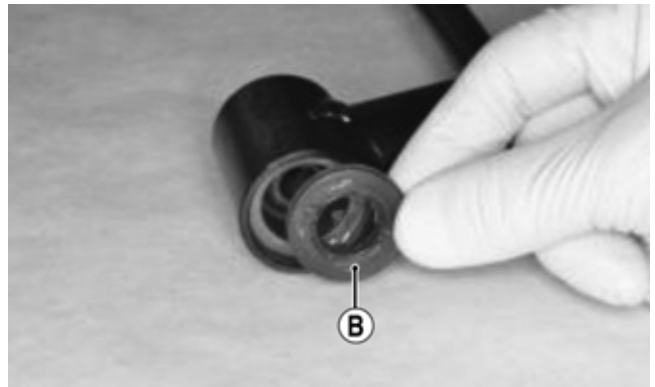

PK290A

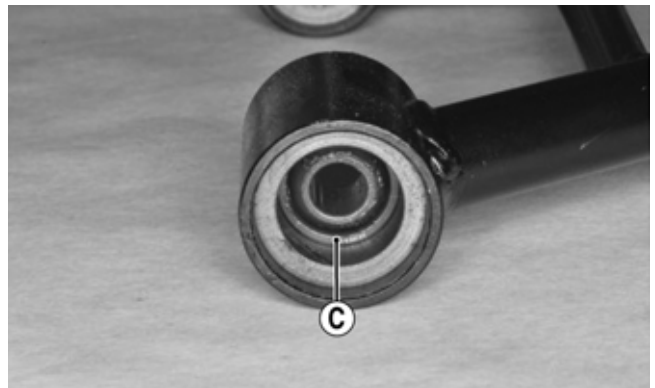

PK291A

8. Remove the snap ring from the ball joint; then remove the ball joint from the A-arm.



PK320

CLEANING AND INSPECTING

1. Clean all A-arm components in parts-cleaning solvent.
2. Clean the ball joint mounting hole of all residual Loctite, grease, oil, or dirt for installing purposes.
3. Inspect the A-arm for bends, cracks, and worn bushings.
4. Inspect the ball joint mounting holes for cracks or damage.
5. Inspect the frame mounts for signs of damage, wear, or weldment damage.

INSTALLING

1. Apply Loctite Primer "T" to the A-arm socket; then apply green Loctite #609 to the entire outside diameter of the ball joint. Install the ball joint into the A-arm and secure with the snap ring.



PK320

2. Install the A-arm assemblies into the frame mounts and secure with the cap screws. Only finger-tighten at this time.

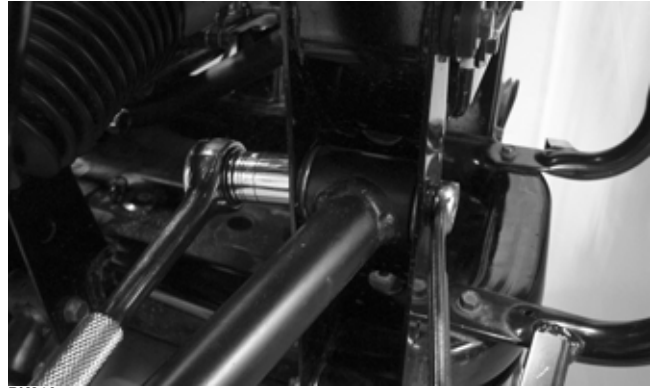

PK319

3. Route the brake hose along the upper A-arm. Secure with hose and clamps.



PK317



PK316

4. Secure the lower eyelet of the shock absorber to the lower A-arm. Tighten nut to 32.5 ft-lb (44.1 N-m).
5. Secure the A-arm assemblies to the frame mounts (from step 2). Tighten the cap screws to 34 ft-lb (46.2 N-m).
6. Install the knuckle assembly onto the ball joints and secure with cap screws. Tighten to 34 ft-lb (46.2 N-m).

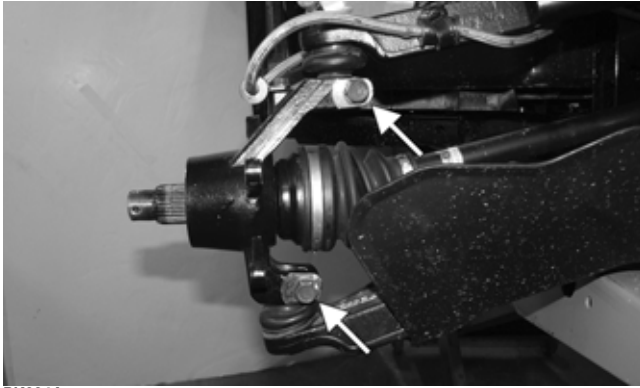

PK234A

7. Install the tie rod end and secure with the washer and nut (coated with red Loctite #271). Tighten to 25 ft-lb (34 N-m); then install a new cotter pin and spread the pin to secure the nut.

■**NOTE:** During assembly, new cotter pins should be installed.



PK121

8. Apply grease to the hub and drive axle splines; then install the hub (see Drive System).

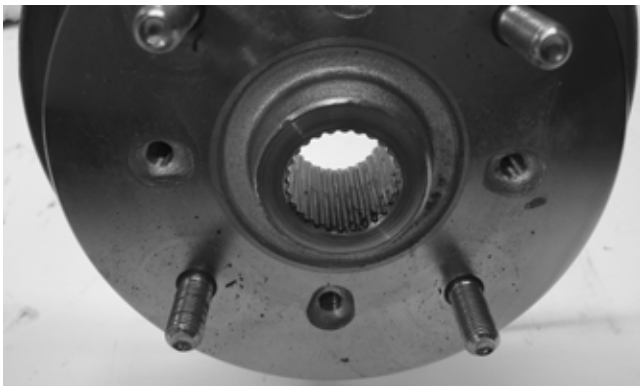

PK127

9. Secure the brake caliper holder to the knuckle with two new “patch-lock” cap screws. Tighten to 19 ft-lb (25.8 N-m).

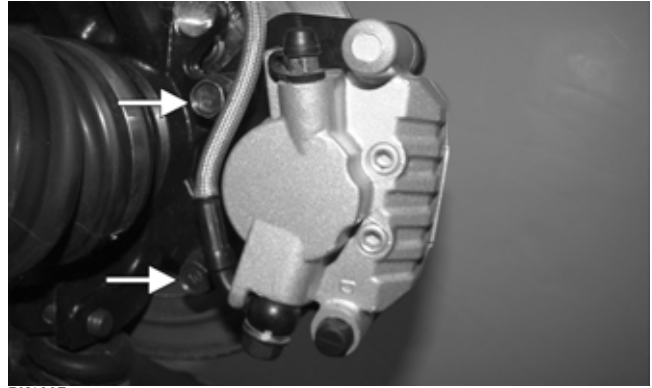

PK106B

10. Install the wheels and using a crisscross pattern, tighten the wheel nuts in 20 ft-lb (27.2 N-m) increments to a final torque of 45 ft-lb (61.2 N-m) (steel wheel), 60 ft-lb (81.6 N-m) (aluminum wheel w/black nuts), or 80 ft-lb (108.8 N-m) (aluminum wheel w/chrome nuts).
11. Remove the vehicle from the support stand.

Rear A-Arms

REMOVING

1. With the vehicle in park, secure the vehicle on a support stand to elevate the wheels.

⚠ WARNING

Make sure the vehicle is solidly supported on the support stand to avoid injury.

2. Remove the wheel. Remove the cotter pin; then remove the hub nut to remove the hub.
3. Remove the cap screws and lock nuts securing the knuckles to the A-arms. Discard the lock nuts. Account for the dust seals and pivot bushings.



PK284

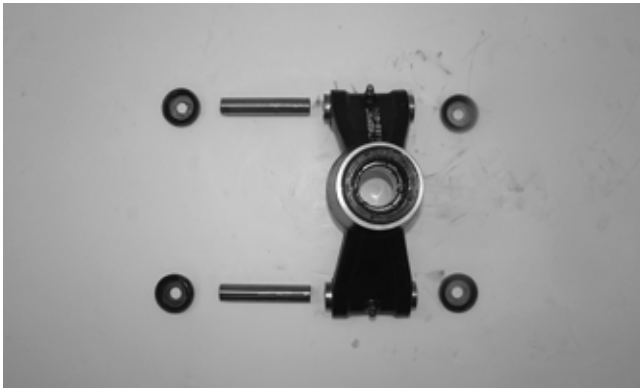

PK285

4. Remove the cap screws and lock nuts securing the shock absorber to the frame and lower A-arm; then remove the A-arm. Account for the collars. Discard the lock nuts.

■NOTE: To replace either upper or lower A-arm bearings, remove the collars and dust seals. Press the bearings out using a suitable sized bearing driver.



PK290



PK291

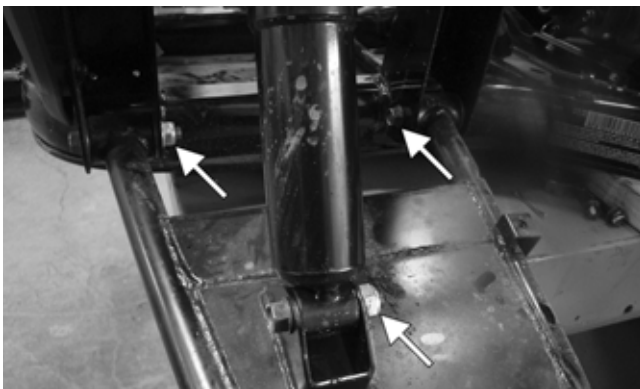

PK286A

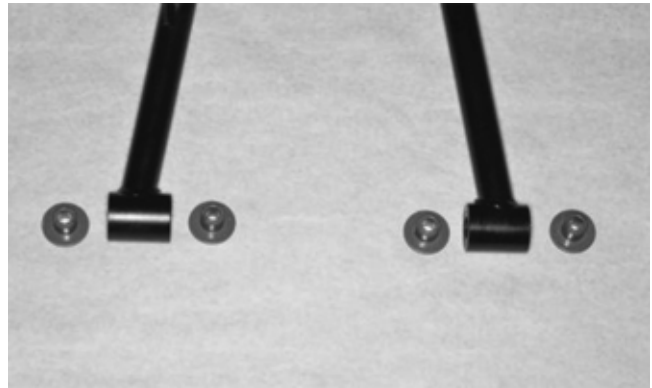

PK287

5. Remove the cap screws securing the rear fascia to the frame. Remove the cap screws and lock nuts securing the upper A-arm to the frame. Account for the collars. Discard the lock nuts.



PK288A

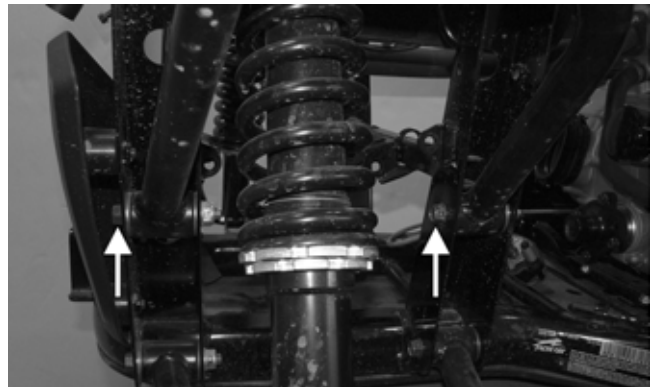

PK289A

CLEANING AND INSPECTING

1. Clean all A-arm components in parts-cleaning solvent.
2. Inspect the A-arm for bends, cracks, and worn bushings or bearings.
3. Inspect the frame mounts for signs of damage, wear, or weldment damage.

INSTALLING

1. Press new bearings into the A-arms, using a driver the same size as the outer race of the bearing; then grease and install new seals.
2. Install the A-arm assemblies into the frame mounts and secure with the cap screws and new lock nuts. Finger-tighten only at this time.

3. Slide the knuckle onto the drive axle and into position on the A-arms; then secure the knuckle with dust seals and pivot bushing to the A-arms with cap screws and new lock nuts. Tighten to 35 ft-lb (47.6 N-m).
4. Tighten the hardware securing the A-arms to the frame mounts (from step 1) to 35 ft-lb (47.6 N-m).
5. Secure the shock absorber to the frame with a cap screw and new lock nut. Tighten to 35 ft-lb (47.6 N-m).
6. Secure the shock absorber to the lower A-arm with a cap screw and new lock nut. Tighten to 35 ft-lb (47.6 N-m).
7. Secure the rear fascia to the frame with the cap screws. Tighten securely.
8. Grease the splines of the hub; then place the hub onto the axle. Install the hub nut and tighten to 200 ft-lb (271.2 N-m). Install a new cotter pin. Attach a grease gun to the fitting and lubricate the knuckle pivot bushings.
9. Install the wheels and using a crisscross pattern, tighten the wheel nuts in 20 ft-lb (27.2 N-m) increments to a final torque of 45 ft-lb (61.2 N-m) (steel wheel), 60 ft-lb (81.6 N-m) (aluminum wheel w/ black nuts), or 80 ft-lb (108.8 N-m) (aluminum wheel w/chrome nuts).
10. Remove the vehicle from the support stand.

Wheels and Tires

TIRE SIZE

 **WARNING**

Use only approved tires when replacing tires. Failure to do so could result in unstable vehicle operation.

This vehicle is equipped with low-pressure tubeless tires of the size and type listed in the General Information section. Do not under any circumstances substitute tires of a different type or size.

 **WARNING**

Always use the size and type of tires specified. Always maintain proper tire inflation pressure.

 **WARNING**

Do not mix tire tread patterns. Use the same pattern type on front and rear. Failure to heed warning could cause poor handling qualities of the vehicle and could cause excessive drivetrain damage not covered by warranty.

TIRE INFLATION PRESSURE

Front and rear tire inflation pressure should be 82.7 kPa (12 psi).

REMOVING

1. Secure the vehicle on a support stand to elevate the wheels.

 **WARNING**

Make sure the vehicle is solidly supported on the support stand to avoid injury.

2. Remove the nuts securing the wheels; then remove the wheels.

CLEANING AND INSPECTING

1. Clean the wheels and hubs with parts-cleaning solvent.
2. Clean the tires with soap and water.
3. Inspect each wheel for cracks, dents, or bends.
4. Inspect each tire for cuts, wear, missing lugs, and leaks.

INSTALLING

1. Install each wheel on its hub and secure with the existing hardware.
2. Using a crisscross pattern, tighten the wheel nuts in 20 ft-lb (27.2 N-m) increments to a final torque of 45 ft-lb (61.2 N-m) (steel wheel), 60 ft-lb (81.6 N-m) (aluminum wheel w/black nuts), or 80 ft-lb (108.8 N-m) (aluminum wheel w/chrome nuts).

CHECKING/INFLATING

1. Using an air pressure gauge, measure the air pressure in each tire. Adjust the air pressure as necessary to meet the recommended inflation pressure.
2. Inspect the tires for damage, wear, or punctures.

 **WARNING**

Do not operate the vehicle if tire damage exists.

■NOTE: If repair is needed, follow the instructions found on the tire repair kit or remove the wheel and have it repaired professionally.

■NOTE: Be sure all tires are the specified size and have identical tread pattern.

Troubleshooting

Problem: Suspension too soft	
Condition	Remedy
<ol style="list-style-type: none"> 1. Spring preload incorrect 2. Spring(s) weak 3. Shock absorber damaged 4. Rear shock absorbers too soft 	<ol style="list-style-type: none"> 1. Adjust preload 2. Replace spring(s) 3. Replace shock absorber 4. Check and adjust air pressure in shocks
Problem: Suspension too stiff	
Condition	Remedy
<ol style="list-style-type: none"> 1. Spring preload incorrect 2. A-arm-related bushings worn 	<ol style="list-style-type: none"> 1. Adjust preload 2. Replace bushing
Problem: Suspension noisy	
Condition	Remedy
<ol style="list-style-type: none"> 1. Cap screws (suspension system) loose 2. A-arm-related bushings worn 	<ol style="list-style-type: none"> 1. Tighten cap screws 2. Replace bushings
Problem: Vehicle pulling or steering erratic	
Condition	Remedy
<ol style="list-style-type: none"> 1. Vehicle steering is erratic on dry, level surface 2. Vehicle pulls left or right on dry, level surface 	<ol style="list-style-type: none"> 1. Check front wheel alignment and adjust if necessary (see Steering/Body/Controls – Front Wheel Alignment) 2. Check air pressure in tires and adjust to specifications

NOTES

TRACKER
 ***OFF ROAD***™

©2021 TRACKER OFF ROAD™
®™ Trademarks of White River Marine Group, LLC