



SERVICE MANUAL

TRACKER OX 400

699671-F

For any questions on material contained in this manual, contact an authorized representative for clarification.

Read and understand all labels located on the vehicle. Always replace any damaged or missing labels.

The following symbols appear throughout this manual and on your vehicle. Your safety is involved when these symbols are used. Become familiar with their meanings before reading the manual.

 **DANGER** indicates a hazardous situation that, if not avoided, will result in death or serious injury.

 **WARNING** indicates a hazardous situation, if not avoided, could result in death or serious injury.

 **CAUTION** indicates a hazardous situation that, if not avoided, could result in minor or moderate injury.

 **WARNING** Failure to comply with the warnings in this manual can result in severe injury or death.

 **WARNING** Read this entire manual carefully before operating this vehicle. Do not attempt to operate this vehicle until you have thorough knowledge of the controls and features.

 **WARNING** Regular inspections and maintenance, along with good operating techniques, will help ensure your safe enjoyment of the capabilities and reliability of this vehicle.

MANUFACTURER'S INTENDED USE

This vehicle is designed and manufactured in the United States of America (USA). The standards and specifications listed in the following text originate in the USA unless otherwise indicated.

EXHAUST EMISSION

The exhaust emissions of this vehicle's engine complies with regulations set forth by the Environmental Protection Agency (EPA) of the United States of America (USA) at time of manufacture. Significant fines could result from modifications or tampering with the engine, fuel ignition or air intake systems.

BATTERY PROLONGED STORAGE

Batteries discharge over time. The rate of discharge changes according to the ambient temperature, the age and condition of the batteries.

Completely charged batteries will not freeze in winter temperatures unless the temperature is less than -75°F (-60°C).

BATTERY DISPOSAL

Lead-acid batteries are recyclable. Return discarded batteries to distributor, manufacturer or lead smelter for recycling. For neutralized spills, put residue in acid-resistant containers with absorbent material such as sand. Dispose in accordance with local, state and federal regulations for acid and lead compounds. Contact local or state environmental authorized people for the disposal information.

REPAIR AND SERVICE MANUAL

OX 400 GASOLINE EFI VEHICLE

Starting MODEL YEAR 2020

CALIFORNIA Proposition 65 Warning

WARNING: Motor vehicles may contain fuels, oils and fluids, battery posts, terminals, and related accessories which contain lead, lead compounds and other chemicals identified by the State of California to potentially cause cancer, birth defects and other reproductive harm. These chemicals are found in vehicles, vehicle parts and accessories, both new and replacements. During maintenance, these vehicles generate used oil, waste fluids, grease, fumes and particulates, all identified by the State of California to potentially cause cancer, birth defects, and other reproductive harm.

This vehicle has been designed and manufactured in the United States of America (USA). The Standards and Specifications listed in the following text originate in the USA unless otherwise indicated.

MANUFACTURER INFORMATION
Textron Specialized Vehicles, Inc.
1451 Marvin Griffin Road
Augusta, Georgia, USA 30906-3852

Dealer: 800-296-4804
Consumer: 877-394-6727

www.trackeroffroad.com

GENERAL INFORMATION

The use of non-Original Equipment Manufacturer (OEM) approved parts may void the warranty.

Overfilling battery may void the warranty.

Tampering with or adjusting the governor to permit vehicle to operate above factory specifications will void the vehicle warranty.

When servicing engines, all adjustments and replacement components must be per original vehicle specifications in order to maintain the United States of America Federal and State emission certification applicable at the time of manufacture.

BATTERY PROLONGED STORAGE

Batteries self-discharge over time. The rate of self-discharge varies depending on the ambient temperature, the age and condition of the battery.

A fully charged battery will not freeze unless the temperature falls below -75°F (-60°C).

For winter storage, the batteries must be clean, fully charged and disconnected from any source of electrical drain.

The battery charger can remain connected to the vehicle to maintain a full charge on the batteries. If power to the charger is disconnected or interrupted, the battery charger continues to check the charge on the battery pack. This pulls power from the battery pack and eventually drains the batteries if power is not restored in a timely manner.

As with all electric vehicles, the batteries must be checked and recharged as required or at a minimum of 30 day intervals.

Check and maintain the proper fluid level in all battery cells during the storage period. Correct fluid level is required for maximum battery performance.

BATTERY DISPOSAL

Lead-acid batteries are recyclable. Return whole scrap batteries to distributor, manufacturer or lead smelter for recycling. For neutralized spills, place residue in acid-resistant containers with absorbent material, sand or earth and dispose of in accordance with local, state and federal regulations for acid and lead compounds. Contact local and/or state environmental officials regarding disposal information.

SAFETY INFORMATION

This manual has been designed to assist in the maintenance of the vehicle in accordance with procedures developed by the manufacturer. Following these procedures and troubleshooting tips will ensure the best possible service from the product. To reduce the chance of personal injury and/or property damage, the following instructions must be carefully observed:

Certain replacement parts can be used independently and/or in combination with other accessories to modify this vehicle to permit the vehicle to operate at or in excess of 20 mph. When a vehicle is modified in anyway by the Distributor, Dealer, or customer to operate at or in excess of 20mph on public streets or roads. UNDER FEDERAL LAW the modified product will be a Low Speed Vehicle (LSV) subject to the strictures and requirement of Federal Motor Vehicle Safety Standard 571.500. In these instances, pursuant to Federal law the Distributor or Dealer MUST equip the product with headlights, rear lights, turn signals, seat belts, top, horn and all other modifications for LSV's mandated in FMVSS 571.500, and affix a Vehicle Identification Number to the product in accordance with the requirements of FMVSS 571.565. Pursuant to FMVSS 571.500, and in accordance with the State laws applicable in the places of sale and use of the product, the Distributor, Dealer or customer modifying the vehicle also will be the Final Vehicle Manufacturer for the LSV, and required to title or register the vehicle as mandated by State law.

Information on FMVSS 571.500 is found at Title 49 of the Code of Federal Regulations, section 571.500. For information online, go to www.ecfr.gov.

The manufacturer will NOT approve Distributor, Dealer or customer changes that change this product into a Low Speed Vehicle (LSV).

This vehicle meets the current applicable standard for safety and performance requirements.

GENERAL

Many vehicles are used for a variety of tasks beyond their original intended use; therefore it is impossible to anticipate and warn against every possible combination of circumstances that may occur. Warnings cannot replace good common sense driving practices. Common sense driving practices do more to prevent accidents and injury than warnings and instructions can provide.

The manufacturer strongly suggests anyone operating the vehicle read the entire owner's manual provided with the purchase of the vehicle, paying particular attention to the CAUTIONS, WARNINGS and DANGERS within.

For any questions or concerns, contact your dealer.

The manufacturer of this vehicle reserves the right to make design changes without obligation to make these changes on units previously sold and the information in this manual is subject to change without notice.

The manufacturer is not liable for errors in this manual or for incidental or consequential damages that result from the use of the material in this manual.

This vehicle conforms to the current applicable standard for safety and performance requirements.

This vehicle is designed and manufactured for off road use. It does not conform to Federal Motor Vehicle Safety Standards and is not intended for operation on public streets.

Refer to GENERAL SPECIFICATIONS for vehicle seating capacity. Do not exceed number of occupants indicated.



Never modify the vehicle in any way that will alter the weight distribution of the vehicle, decrease its stability, increase the speed or extend the stopping distance beyond the factory specification. Such modifications can result in serious personal injury or death.

Modifications that increase the speed and/or weight of the vehicle will extend the braking distance and may reduce the stability of the vehicle. Do not make any such modifications or changes. The manufacturer prohibits and disclaims responsibility for any such modifications or any other alteration which would adversely affect the safety of the vehicle.

Speed should be moderated by the environmental conditions, terrain and common sense.

GENERAL OPERATION

ALWAYS:

- Use the vehicle in a responsible manner.
- Read and observe all warnings and operation instruction labels affixed to the vehicle.
- Follow all safety rules in the area where the vehicle is being operated.
- When there is a risk of lightning, leave the vehicle and look for a safe location to wait until the lightning has stopped.
- Reduce speed to compensate for poor terrain or conditions.
- Apply service brakes to control speed on steep grades.
- Reduce speed in damp or wet areas.
- Reduce speed and use caution when approaching sharp or blind turns.
- Reduce speed and use caution when driving over loose terrain.
- Reduce speed and use caution when driving in areas where pedestrians are present.
- Keep enough distance between vehicles to stop safely.

MAINTENANCE

ALWAYS:

- Replace damaged or missing warning, caution or information labels.
- Service the vehicle according to the manufacturer's scheduled maintenance chart.
- Make sure that repairs are performed by trained and qualified personnel.
- Follow the manufacturer's maintenance procedures.
- Use insulated tools within the battery area to decrease the risk of sparks or battery explosion.
- Use specified replacement parts. DO NOT use replacement parts of lesser quality.
- Use recommended tools.
- Make sure tools and procedures not specified by the manufacturer will not be a safety risk to personnel or operation of the vehicle.
- Use wheel chocks and support the vehicle on jack stands. Never get under a vehicle that is supported by a jack. Lift the vehicle in accordance with the manufacturer's instructions.
- Make sure you service the vehicle in an area away from open flame or sparks.
- Know that a vehicle in need of repair does not operate correctly and can be dangerous to operate.
- After completing repairs or maintenance, test the vehicle in a safe area where there are no vehicles or pedestrian traffic.
- Make sure you record and keep all of the maintenance history of the vehicle.

VENTILATION

ALWAYS:

- Store the gasoline vehicles in a well ventilated area. Good ventilation decreases the risk of gasoline fumes accumulating.
- Never fuel a vehicle in an area that is subject to flame or spark. Pay particular attention to natural gas or propane water heaters and furnaces.
- Never work around or operate a vehicle in an environment that does not allow ventilation of exhaust gases from the area. Carbon monoxide is a dangerous gas that can cause unconsciousness and is potentially lethal.

TABLE OF CONTENTS

SAFETY INFORMATION

GENERAL	III
GENERAL OPERATION	IV
MAINTENANCE	IV
VENTILATION.....	IV

GENERAL INFORMATION AND ROUTINE MAINTENANCE

SERIAL NUMBER LABEL LOCATION	1
VEHICLE WITH A DISCHARGED BATTERY	1
STARTING VEHICLE ON A HILL	1
SERVICING THE VEHICLE	2
FUEL	2
FUEL TANK	2
BATTERY.....	3
ROUTINE MAINTENANCE	3
POWERTRAIN MAINTENANCE.....	3
BRAKES.....	3
TIRES.....	3
LIGHT BULB REPLACEMENT	3
TRANSPORTING VEHICLE	4
Towing	4
Neutral Lock	4
HAULING	4
CANOPY AND WINDSHIELD	4
WINTER OR PROLONGED STORAGE	4
VEHICLE CLEANING AND CARE	5
VEHICLE CARE PRODUCTS.....	5
HARDWARE	6
TORQUE SPECIFICATIONS.....	6

SAFETY

NOTICES, CAUTIONS, WARNINGS AND DANGERS	7
IMPORTANT SAFETY WARNING.....	7
MODIFICATIONS TO VEHICLE	7
GENERAL MAINTENANCE.....	7
BEFORE SERVICING THE VEHICLE	7

TABLE OF CONTENTS

BATTERY REMOVAL / INSTALLATION	9
LIFTING THE VEHICLE.....	9
Lifting Front of Vehicle	10
Lifting Rear of Vehicle	10
Lowering Vehicle	10

BODY

GENERAL.....	11
BODY COMPONENT REPLACEMENT	11
Front Body Components	12
Instrument Panel Replacement	12
Brush Guard Replacement	13
Cowl Replacement	13
Front Bumper Replacement	14
Rocker Panel Replacement	14
Side Panel Replacement	14
Seat Filler Panel Replacement	15
Rear Body Panel Replacement	15
Rear Fender Replacement	16
PAINTING.....	16
Minor Scratches	16
Larger Scratches	16
Complete Panel Repair	17

TRUCK BED

TRUCK BED REMOVAL.....	20
------------------------	----

SPEED CONTROL

SYSTEM OPERATION.....	21
Pedal Box Operation	21
Governor Operation	21
FAULT TESTING.....	22
SPEED CONTROL	22
Accelerator Cable Removal at Governor	22
Accelerator Cable Removal at Pedal Box	22
Accelerator Cable Installation	23
Accelerator Cable Adjustment	23

TABLE OF CONTENTS

Throttle Rod Removal	23
Throttle Rod Adjustment	23
PEDAL BOX ADJUSTMENTS	23
Accelerator Pedal Arm Adjustment	23
Micro Switch Adjustment	24
Road Test	24
WEATHER PROTECTION	
GENERAL	27
Transporting Vehicle	27
CANOPY TOP.....	27
Front Strut Installation	27
Rear Support Installation	27
Canopy Top Installation	27
.....	27
FLAT WINDSHIELD.....	29
SPLIT WINDSHIELD.....	30
WHEELS AND TIRES	
WHEEL AND TIRE SERVICE.....	31
Recommended Tire Pressure	31
Tire Repair	31
Wheel Installation	32
BRAKES	
BRAKE SYSTEM OVERVIEW.....	33
General Description	33
How the Brake Works	33
Equalizer Link	34
Automatic Adjuster Mechanism	34
How the Parking Brake Works	34
Kick-Off Actuating Linkage	34
Compensator Assembly	34
FAULT TESTING FLOWCHART	35
FAULT TESTING TABLE.....	37
FAULT DIAGNOSIS AND INSPECTION	38
New Vehicle	38

TABLE OF CONTENTS

Fault Diagnosis and Inspection Procedures	38
Brake Pedal and Linkage Inspection	38
Daily Brake Performance Test	41
Brake System Inspection	41
Wheel Brake Inspection	41
MAINTENANCE AND REPAIRS	43
Adjusting Brake Pedal Free Travel	44
Brake Drum Removal and Installation	45
Wheel Brake Service	45
Backing Plate/Entire Wheel Brake Assembly Removal and Installation	46
Brake Shoe Removal	47
Brake Shoe Installation	49
Brake Cable and Equalizer Assembly Removal and Installation	50
Compensator Assembly, Removal and Installation	50
Brake Pedal Removal and Installation	50
Parking Brake Catch Bracket Removal and Installation	51
Parking Brake Pedal Removal and Installation	51
Pedal Bumper Adjustment	52
Parking Brake Release Linkage Removal and Replacement	52
Parking Brake Kick-Off Cam Removal, Replacement and Installation	52

FRONT HYDRAULIC BRAKES

SYSTEM DESCRIPTION.....	53
MASTER CYLINDER REPLACEMENT.....	53
Remove Master Cylinder	53
Install Master Cylinder	54
MASTER CYLINDER FLUID	54
Flush Hydraulic Brake System	54
Check Brake Fluid	54
ROUTINE MAINTENANCE.....	54
REPLACEMENT OF WEAR ITEMS	55
Brake Pad Replacement	55
Rotor Replacement	55
Spindle Replacement	55
Actuator Linkage Bushings	55
Actuator Pivot Bushings	55

TABLE OF CONTENTS

BLEEDING BRAKES	55
General Information about Bleeding Brakes	56
Brake Bleeding Procedure	56
REAR HYDRAULIC BRAKES	
SYSTEM DESCRIPTION	59
Daily Brake Performance Test	59
Brake System Inspection	59
BRAKE DRUM REMOVAL AND INSTALLATION	59
WHEEL BRAKE SERVICE	61
Cleaning and Inspection	61
Reassembly	62
FRONT SUSPENSION AND STEERING	
MAINTENANCE	64
Lubrication	64
Wheel Bearing and King Pin Bushing Inspection	64
Wheel Bearing Packing	64
Wheel Bearing Adjustment	65
Wheel Alignment	65
FRONT SUSPENSION	67
Front Shock Absorber Replacement	67
Front Axle Replacement	68
Front Spring Replacement	69
Hub Replacement	70
Wheel Bearing and Race Replacement	70
STEERING	71
Rack Ball Joint Replacement	71
Tie Rod Inspection/Replacement	72
Bellows Replacement	73
Pinion Seal Replacement	73
Spindle Replacement	74
Rack and Pinion Unit Disassembly and Inspection	75
Rack and Pinion Unit Replacement	76
Checking/Adjusting Rack Extension-to-Rack and Pinion Unit Clearance	76
Steering Wheel Replacement	77
Steering Shaft and Column Replacement	78

TABLE OF CONTENTS

REAR AXLE

NEUTRAL LOCK	81
Checking the Lubricant Level	81
REAR AXLE DISASSEMBLY	82
Axle Shaft Removal and Disassembly	82
Axle Shaft Seal Removal and Replacement	82
Axle Shaft Replacement	83

REAR SUSPENSION

General	85
Shock Absorber	85
Shock Absorber Removal	85
Shock Absorber Installation	85
Rear Leaf Spring	85
Rear Leaf Spring Removal	86
Rear Leaf Spring Installation	86

CONTINUOUSLY VARIABLE TRANSMISSION (CVT)

GENERAL.....	89
CLUTCHES.....	89
Primary Clutch	89
Secondary Clutch	90
Increased Load	90
Equilibrium	90
Removing the Transmission Belt	90
Transmission Belt Service	90
Primary Clutch Removal	90
.....	91
Primary Clutch Installation	92
Secondary Clutch Removal	92
Secondary Clutch Repair	92
Secondary Clutch Assembly	92
Secondary Clutch Installation	92
STORAGE	92

ENGINE

POWERTRAIN MAINTENANCE	93
------------------------------	----

TABLE OF CONTENTS

Checking the Oil Level	93
Changing the Oil	93
AIR FILTER INSPECTION/REPLACEMENT	95
Cleaning the Air Filter Element	95
STARTER/GENERATOR BELT TENSION.....	95
Adjusting the Belt	96
STARTER/GENERATOR REPLACEMENT (REF. FIG. 12).....	96
COOLING SYSTEM CLEANING	97
SPARK PLUG	97
FOUR CYCLE ENGINE	98
Engine Specifications	98
Engine Description	98
CYLINDER HEAD	98
Compression Measurement	98
Rocker Cover Removal	99
Valve Clearance Adjustment	99
ENGINE REMOVAL.....	100
Controls and Wiring	100
Removing the Engine from the Vehicle	100
Engine Installation	101
DRIVE CLUTCH REMOVAL.....	101
FUEL SYSTEM	
GENERAL	104
FUEL	104
FUEL SYSTEM SERVICE	104
Fuel Tank Removal	104
Fuel Pump Assembly	105
FUEL INJECTOR REMOVAL	105
MALFUNCTION INDICATOR LIGHT (MIL)	106
WALBRO IRIS SERVICE TOOL EFI DIAGNOSTICS.....	107
Communication Module	107
Jumper Harness	107
Connect to Vehicle	108
Download software file from TSV Connect	108
Connect to the ECU	108

TABLE OF CONTENTS

Parameters for Viewing	108
Record Log File	108
View Log File	108
Update ECM	109
Troubleshooting	110
Fault Check	111
Pedal Kill Check	112
Tests	112
RECOMMENDED FAULT TESTS	112
Ignition System	112
Fuel Pump	113
Other	113

ELECTRICAL

CIRCUITS AND CONTROLS	115
STARTER	115
GENERATOR	115
WIRING.....	115
TESTING THE IGNITION CIRCUIT.....	115
Testing the Magneto	117
TESTING THE STARTING CIRCUIT	118
TESTING THE CHARGING CIRCUIT	118
INSPECTION	119
STARTER/GENERATOR	120
Starter/Generator Removal	120
Disassembly	120
Repair and Replacement	120
VOLTAGE TEST FOR BATTERY.....	120
STORAGE OF BATTERY.....	121
DVOM (DIGITAL VOLT OHM METER)	121
FAULT TESTING	121
POWER SUPPLY	122
ACCESSORY WIRING	122
LIGHT BULB REPLACEMENT	122
Headlight Bulb Replacement	122
Taillight Replacement	123

TABLE OF CONTENTS

FAULT TESTING

General	125
Voltmeter	125
Continuity Check	125
Testing a Switch for Continuity	125
Testing the Ignition System	125
Testing Fuses	125
POWERTRAIN PERFORMANCE	126
STARTER FAULT TESTING	128
SUSPENSION AND STEERING FAULT TESTING.....	128

GENERAL SPECIFICATIONS

SPECIFICATIONS CHART	131
----------------------------	-----

SCHEDULED MAINTENANCE

RECOMMENDED LUBRICANTS AND FLUIDS	139
REPLACEMENT OF MAINTENANCE ITEMS	139

TABLE OF CONTENTS

GENERAL INFORMATION AND ROUTINE MAINTENANCE

SERIAL NUMBER LABEL LOCATION

The vehicle has multiple serial number and manufacture date code plates. PARTS A and B are found on the support bracket below the front seat. Lift the seat and the flap to access PARTS A and B (Fig. 1). PART C is found on

the body panel below the driver seat. PART D is found on the frame tube below the floorboard.

Design changes take place on an ongoing basis. The information on these labels must be provided to obtain correct replacement components for the vehicle.

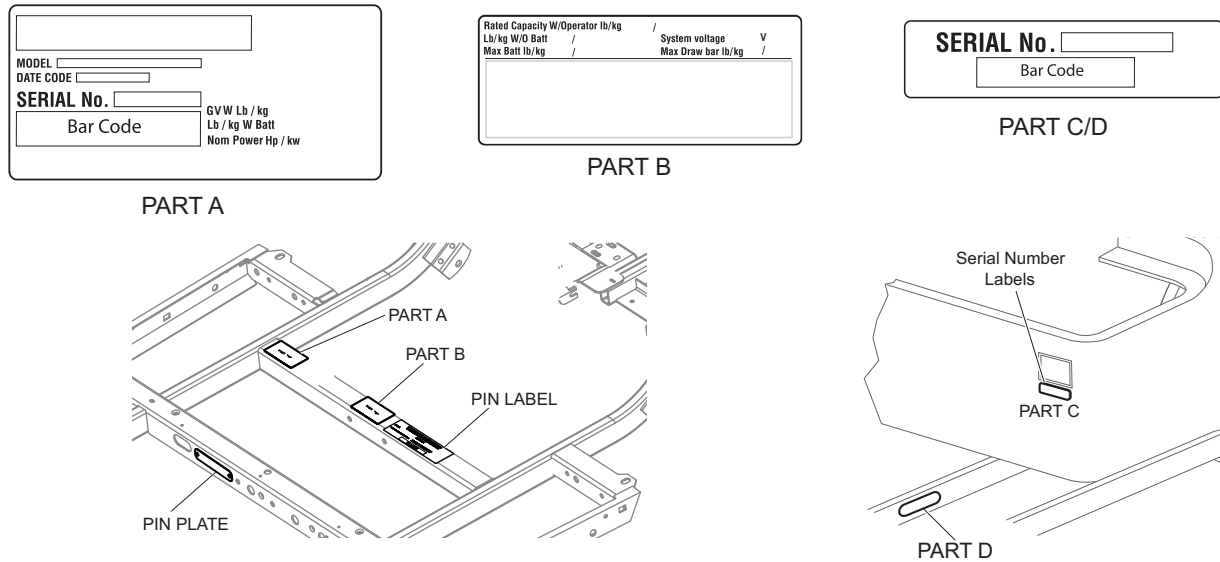

Fig. 1 Serial Number Locations

VEHICLE WITH A DISCHARGED BATTERY

WARNING To decrease the risk of severe injury or death from accidental movement, do not use jumper cables to start a vehicle.

The vehicle has a starter/generator and does not idle. When you start the engine, the starter/generator functions as a starter; with the engine running, it functions as a generator.

The generator can keep the battery charged with the short run times typical of this type of vehicle. The generator will not charge a discharged battery.

When the engine starts, the clutches engage and cause the vehicle to move making jump starting both dangerous and impractical.

Since the engine stops when the accelerator is released, **jump starting should not be attempted.**

If the battery has discharged, charge it with a 12V charger that is rated at 10 amps or less and according to instructions supplied by the manufacturer of the charger.

STARTING VEHICLE ON A HILL

WARNING To decrease the risk of roll-back, do not release the service brake until the engine has started

Do not use the accelerator and engine to hold the vehicle on a hill. Doing so will cause early and excessive wear to the drive train components.

To decrease the risk of permanent damage to the drive train, do not allow roll-back when you start the vehicle on a hill.

Put left foot on service brake and release the parking brake. Press the accelerator with right foot and release the service brake.

GENERAL INFORMATION AND ROUTINE MAINTENANCE

Read all of SAFETY and this section before attempting any procedure. Pay particular attention to Notices, Cautions, Warnings and Dangers.

SERVICING THE VEHICLE

⚠ WARNING To decrease the risk of severe injury or death, resulting from improper servicing techniques, observe the following Warnings:

Do not attempt any type of servicing operations before reading and understanding all notices, cautions and warnings in this manual.

The drive wheels must be lifted and supported on jack stands before you do any service to the powertrain when the engine is in operation.



Wear eye protection when you service the vehicle. Be careful when you do work around battery, use solvents or compressed air.

To decrease the risk of electrical arc, which can cause a battery explosion, disable all electrical loads from the battery before you remove the battery wires.

To decrease the risk of engine damage, do not operate the vehicle at full throttle for more than 5 seconds with the drive wheels lifted off the ground.

The vehicle owner and service technician must carefully follow the procedures recommended in this manual. The preventative maintenance, applied at recommended intervals, keeps the vehicle dependable and decreases the costs for the repairs.

In any product, components will eventually fail to perform properly as the result of normal use, age, wear or abuse.

It is virtually impossible to anticipate all possible component failures or the manner in which each component may fail.

A vehicle requiring repair indicates the vehicle is no longer functioning as designed and should be considered potentially hazardous. Use extreme care when working on a vehicle. When diagnosing, removing or replacing any components that are not operating properly, consider the safety of yourself and those around you, should the component move unexpectedly.

Some components are heavy, spring loaded, highly corrosive, explosive, may produce amperage or reach high temperatures. Gasoline, carbon monoxide, battery acid and hydrogen gas could result in serious bodily injury to the technician/mechanic and bystanders, if not treated with the utmost caution. Be careful not to place hands, face, feet or body in a location that could expose them to injury should an unforeseen dangerous situation occur.

Always use the appropriate tools listed in the tool list and wear approved safety equipment.

Before a new vehicle is put into operation, do the items shown in the INITIAL SERVICE CHART.

Item	Service Operation
Battery	Charge battery
Seats	Remove protective plastic covering
Brakes	Check operation and adjust if necessary
	Establish new vehicle braking distance
Tires	Check pressure
Fuel	Fill tank with correct fuel
Engine	Check oil level

Fig. 2 Initial Service Chart

FUEL

⚠ WARNING To decrease the risk of severe injury or death from improper fuel handling:

Do not smoke near the fuel tank.

Do not add fuel near open flame or electrical items that can cause a spark.

Always handle gasoline in a well ventilated area.

Always wear eye protection to protect against splashed fuel and fuel vapors.

Inspect the fuel cap, tank and other components for leaks or damage that can cause a hazardous condition.

Oxygenated or reformulated gasoline, is mixed with alcohols or ethers. Excessive amounts of these blends can damage the fuel system or cause performance problems. If any operating problems occur, use gasoline with a lower percentage of alcohol or ether.

Use clean regular grade unleaded fuel. The Ethanol blend fuel up to 10% is permitted.

Do not use gasoline that contains methanol.

High altitude or heavy use/load applications can benefit from higher octane gasoline.

FUEL TANK

The fuel tank is located below the seat on the passenger side of the vehicle. Fill the tank with clean, automotive grade gasoline.

High octane gasoline can increase the performance of vehicles that are used in high altitudes, have heavy use or heavy load applications.

GENERAL INFORMATION AND ROUTINE MAINTENANCE

Read all of SAFETY and this section before attempting any procedure. Pay particular attention to Notices, Cautions, Warnings and Dangers.

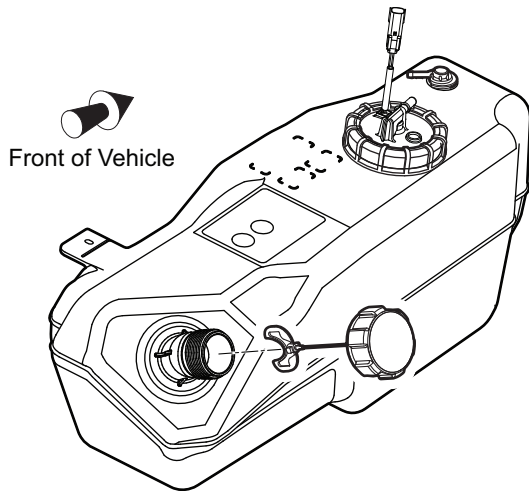

Fig. 3 Fuel Tank

BATTERY

NOTICE: Heavy use of accessories drains the battery which can leave insufficient reserve to start the vehicle.

The vehicle uses a starter/generator to start the engine and charge the battery. The engine will not idle. The battery does not charge while the vehicle is stopped. Do not operate lights and other accessory items excessively while the vehicle is stopped.

The generator can supply 35 amps. Operation of all accessories can cause the discharge of the battery even if the engine is running and the generator is operating. Discharging the battery is known as deep cycling. The battery is not a deep cycle model. It is a starting battery. Multiple deep cycling causes early failure of the battery.

If the battery has discharged, charge it with a 12-volt charger that is rated at 10 amps or less and according to instructions supplied by the manufacturer of the charger.

ROUTINE MAINTENANCE

This vehicle will give years of satisfactory service, providing it receives regular maintenance. Refer to the Scheduled Maintenance section for appropriate service intervals.

NOTICE: Some maintenance items must be serviced more frequently on vehicles used under severe driving conditions.

POWERTRAIN MAINTENANCE

Access the powertrain by raising or removing the seat bottom. Some service procedures may require the vehicle

be lifted. Refer to LIFTING THE VEHICLE in the SAFETY section for proper lifting procedure and safety information.

For maintenance procedures relating to the engine, speed control, fuel system, transmission, and rear axle or suspension refer to the particular section. See TABLE OF CONTENTS for section location.

BRAKES

WARNING Always inspect the pedal travel before you operate a vehicle to confirm some brake function is found.

Make sure you do all brake tests in a safe location with regard to the safety of all personnel.

NOTICE: A subtle loss of performance can occur over time; therefore, it is important to establish the standard stopping distance with a new vehicle.

The Periodic Brake Performance Test should be performed regularly as an evaluation of braking system performance. It is useful as a method of identifying subtle loss of performance over time.

For test method and brake service, refer to BRAKES section.

TIRES

Be sure to reinstall the valve dust cap after checking or inflating the tire.

For additional information, refer to WHEELS AND TIRES section.

LIGHT BULB REPLACEMENT

Refer to ELECTRICAL section for information regarding light bulb replacement.

GENERAL INFORMATION AND ROUTINE MAINTENANCE

Read all of SAFETY and this section before attempting any procedure. Pay particular attention to Notices, Cautions, Warnings and Dangers.

TRANSPORTING VEHICLE

Towing

WARNING Do not ride or allow other people on the vehicle being towed.

Do not try to tow the vehicle with ropes, chains or any device other than a tow bar approved by the factory.

Do not tow a single vehicle at speeds in excess of 12 mph (19 kph).

Do not exceed 5 mph (8 kph) while towing multiple vehicles.

Do not tow more than three vehicles at a time.

Do not tow the vehicle on highways.

Neutral Lock

To decrease the risk of the driven clutch turning the rear wheels during service operations, a neutral lock is located on the direction selector.

To operate: Turn the key switch to OFF and lift the seat. Pull out and rotate the neutral lock pin handle so that the pointed portion of the handle is to the side of the direction selector cam. Move the direction selector towards the area between F and R. During that motion, the pin will snap into the hole in the direction selector mounting bracket preventing any movement.

When in this position, the direction selector remains locked in the neutral position. To unlock the direction selector, pull the neutral lock pin handle out and rotate until the pointed portion of the handle fits into the hole in the direction selector cam.

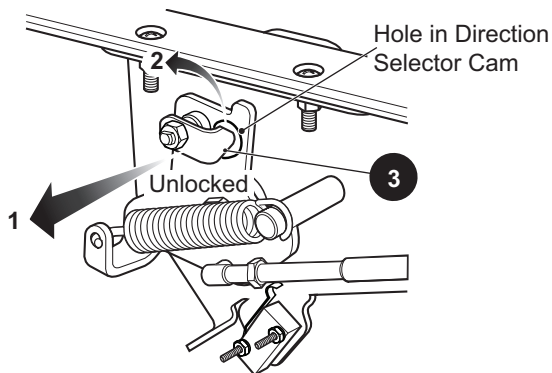

Fig. 4 Neutral Lock

HAULING

WARNING Make sure you secure the vehicle and all items before you transport a vehicle on a trailer.

Do not allow any people on a vehicle being transported on a trailer.

Remove the windshield before you transport a vehicle on a trailer.

Maximum speed with canopy installed is 50 mph (80 kph).

If you transport the vehicle on a trailer at highway speeds, the canopy must be removed and the seat bottom secured.

If the vehicle is to be transported on a trailer below highway speeds, check for tight hardware and cracks in canopy at the mounting points.

The rated capacity of the trailer or truck must be more than the weight of the vehicle and load plus 1000 lbs. (454 kg). See GENERAL SPECIFICATIONS for the weight of the vehicle.

Secure the vehicle to the trailer with ratchet tie downs.

CANOPY AND WINDSHIELD

WARNING The canopy does not provide protection from roll-over or falling objects.

The windshield does not provide protection from tree branches or moving objects.

The canopy and windshield provide some protection from the elements, but do not keep the operator and passenger dry in heavy rain.

Clean the windshield with water and a clean cloth. Minor scratches may be removed using a commercial plastic polish or Plexus plastic cleaner.

WINTER OR PROLONGED STORAGE

WARNING Do not handle fuel in an area that is not adequately ventilated. Do not smoke near the fuel tank or refuel near open flame or electrical items which could produce a spark.

Store vehicle in a clean, dry area. Do not store in the same area as a stove, furnace, water heater, or other appliance that uses a pilot light or has a device that can create a spark.

When refueling, inspect the fuel cap for leaks or breaks that could result in fuel spillage.

GENERAL INFORMATION AND ROUTINE MAINTENANCE

Read all of SAFETY and this section before attempting any procedure. Pay particular attention to Notices, Cautions, Warnings and Dangers.

Always wear safety glasses while refueling to decrease the risk of possible eye injury from gasoline or gasoline vapor.

Keep hands, clothing and jewelry away from moving parts.

Use care not to contact hot objects.

Raise the rear of the vehicle and support on jack stands before attempting to run the engine.

Preparing the engine for a prolonged storage period (30 days or more) calls for a few simple steps to decrease the risk of a build up of varnish and gum in the throttle body and corrosion in the engine.

- Turn the key switch to the OFF position, and leave the Forward/Reverse switch in the NEUTRAL position during storage.
- Perform all required routine maintenance. See SCHEDULED MAINTENANCE section.
- Properly inflate the tires to recommended pressure (psi) stated on the sidewall of tires.
- Place the Forward/Reverse handle in the NEUTRAL position and engage the neutral lock.
- Turn the fuel shut-off valve to the closed (OFF) position

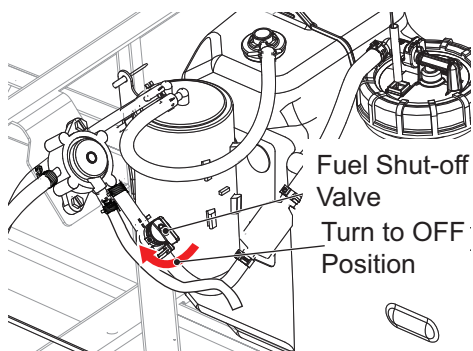

Fig. 5 Fuel Shut Off Valve

- With proper ventilation, run the engine until the remaining fuel in fuel lines is depleted and the engine stalls.
- Return the neutral lock to the OPERATE position.
- Add fuel stabilizer to the fuel (follow manufacturing instruction) to stabilize fuel and install the tank cap securely.
- Remove spark plug and Pour 1/2 oz. (15 ml) of SAE 10 - 30 weight oil or fogging oil into the cylinder. Rotate the crankshaft by hand several times, Install the spark plug.
- Do not engage the park brake, but secure the car from rolling.
- Change the oil while the engine is warm.

- Clean the body, chassis and engine of debris, mud, chaff or grass

VEHICLE CLEANING AND CARE

WARNING Read and understand all instructions supplied by the manufacturer of the pressure washer before use.

NOTICE: When you clean the outside of the vehicle with a pressure washer, do not use more than 700 psi pressure. Keep a minimum distance of 12 inches from the spray nozzle to the painted surface. Do not clean the plastic parts with abrasive solvents.

Make sure you use correct methods and cleaning materials to decrease the risk of damage to the outside of the vehicle. The use of more than 700 psi water pressure can cause injury to anyone in the area or damage to vehicle.

Clean the windshield with water and a clean cloth. Remove small scratches with a plastic polish or Plexus® plastic cleaner, available from the service parts department.

Apply a soap and water solution with a sponge or soft brush to clean the vinyl seats and plastic or rubber trim. Dry with a cloth.

Use a commercially available vinyl and rubber cleaner to remove oil, tar, asphalt, shoe polish, etc.

Wash the vehicle frequently with cool water and mild detergent to protect the painted surfaces.

Apply wax that is for clear coat automotive finishes to improve the appearance and protection of the painted surfaces. Do not apply wax to matte finish surfaces.

Materials used as fertilizers or for dust control can collect on the bottom of the vehicle. These materials will cause corrosion of components, unless cleaned with water. Clean areas where mud or dirt can collect. Loosen the sediment that is packed in closed areas to help with removal. Be careful not to damage the paint.

VEHICLE CARE PRODUCTS

To help maintain the vehicle, the manufacturer has several products, available through a local Distributor, an authorized Branch, or the Service Parts Department, among them are:

GENERAL INFORMATION AND ROUTINE MAINTENANCE

Read all of SAFETY and this section before attempting any procedure. Pay particular attention to Notices, Cautions, Warnings and Dangers.

- Touch-up paint specially formulated to match vehicle colors for use on both metal and TPE (plastic) bodies. (Contact a service parts representative for availability).
- Multi-purpose Battery Protectant (P/N 27619G01) formulated to form a long-term, flexible, non-tacky, dry coating that will not crack, peel or flake over a wide temperature range.
- Use windshield and plastic protectant (P/N 606314) to remove minor scratches from windshield.

HARDWARE

Periodically inspect the vehicle for loose fasteners. Use care when tightening fasteners. Refer to the following table for torque values (Ref. Fig. 6).

Standard:

- Grade 2 hardware is unmarked.
- Grade 5 hardware can be identified by the three marks on the hex head.
- Grade 8 hardware is identified by six marks on the head.

The class specification is marked on metric hardware.

TORQUE SPECIFICATIONS







ALL TORQUE FIGURES ARE IN FT. LBS. (Nm)											
Unless otherwise noted in text, tighten all hardware in accordance with this chart.											
This chart specifies 'lubricated' torque figures. Fasteners that are plated or lubricated when installed are considered 'wet' and require approximately 80% of the torque required for 'dry' fasteners.											
BOLT SIZE	1/4"	5/16"	3/8"	7/16"	1/2"	9/16"	5/8"	3/4"	7/8"	1"	
Grade 2 	4 (5)	8 (11)	15 (20)	24 (33)	35 (47)	55 (75)	75 (102)	130 (176)	125 (169)	190 (258)	
Grade 5 	6 (8)	13 (18)	23 (31)	35 (47)	55 (75)	80 (108)	110 (149)	200 (271)	320 (434)	480 (651)	
Grade 8 	6 (8)	18 (24)	35 (47)	55 (75)	80 (108)	110 (149)	170 (230)	280 (380)	460 (624)	680 (922)	
BOLT SIZE	M4	M5	M6	M8	M10	M12	M14				
Class 5.8 (Grade 2) 	1 (2)	2 (3)	4 (6)	10 (14)	20 (27)	35 (47)	55 (76.4)				
Class 8.8 (Grade 5) 	2 (3)	4 (6)	7 (10)	18 (24)	35 (47)	61 (83)	97 (131)				
Class 10.9 (Grade 8) 	3 (4)	6 (8)	10 (14)	25 (34)	49 (66)	86 (117)	136 (184)				

Fig. 6 Torque Specifications

SAFETY

NOTICES, CAUTIONS, WARNINGS AND DANGERS

The following symbols appear throughout this manual and on your vehicle. Your safety is involved when these symbols are used. Become familiar with their meanings before reading the manual.

⚠ DANGER *DANGER indicates a hazardous situation that, if not avoided, will result in death or serious injury.*

⚠ WARNING *WARNING indicates a hazardous situation, if not avoided, could result in death or serious injury.*

⚠ CAUTION *CAUTION indicates a hazardous situation that, if not avoided, could result in minor or moderate injury.*

IMPORTANT SAFETY WARNING

In any product, components will eventually fail to perform properly as the result of normal use, age, wear or abuse.

It is impossible to anticipate all possible component failures or the manner in which each component may fail.

Be aware that a vehicle requiring repair indicates that the vehicle is no longer functioning as designed and therefore should be considered potentially hazardous. Use extreme care when working on any vehicle. When diagnosing, removing or replacing any components that are not operating correctly, take the time to consider the safety ramifications if the component should move unexpectedly.

Some components are heavy, spring loaded, highly corrosive, explosive or may produce high amperage or reach high temperatures. Exposure to battery acid and hydrogen gas could result in serious bodily injury to the technician/mechanic and bystanders if not treated with utmost caution. Be careful not to place hands, face, feet or body in a location that could expose them to injury should an unexpected situation occur.

Always use the appropriate tools listed in the tool list and wear approved safety equipment.

MODIFICATIONS TO VEHICLE

Do not modify the vehicle in any manner that will change the weight distribution of the vehicle.

⚠ WARNING *Changes to the weight distribution or the center of gravity may make the vehicle unstable or prone to roll-over which could result in injury or death to the operator or passengers.*

GENERAL MAINTENANCE

⚠ WARNING *To prevent severe injury or death resulting from improper servicing techniques, do not attempt any type of servicing operations before reading and understanding all notices, cautions and warnings in this manual.*

When maintenance procedures or inspection are performed, ensure the safety of the technician/mechanic or bystanders, and to prevent damage to the vehicle.

Always read and understand the entire relevant manual section (chapter) before attempting any inspection or service.

BEFORE SERVICING THE VEHICLE

Before inspecting or servicing a vehicle, read and understand the following warnings:

⚠ WARNING *Before working on the vehicle, remove all jewelry.*

Make sure that clothing or hair cannot become caught in the moving parts of the powertrain.

Do not contact hot objects.

Before attempting to operate or adjust the powertrain, the vehicle must be raised and supported on jack stands.

Wear OSHA approved clothing and eye protection when working on anything that could expose the body or eyes to potential injury. Use care when working with or around batteries, compressed air or solvents.

Always turn the key switch to OFF and remove the key before disconnecting a live circuit.

When connecting battery cables, pay particular attention to the polarity of the battery terminals. Never confuse the positive and negative cables.

Engage the parking brake, except when the powertrain must be allowed to rotate or the brake system needs service.

SAFETY

Read all of SAFETY and this section before attempting any procedure. Pay particular attention to Notices, Cautions, Warnings and Dangers.

The shifter must always be placed in the P (park) position, except for cases where the powertrain must be allowed to rotate or service is being performed on the brake system.

If repairs are to be made that will require welding or cutting, the battery and fuel tank must be removed and the fuel system drained.

To prevent an explosion that could result in severe injury or death, keep all smoking materials, open flame or sparks away from gasoline and battery.

Never operate the starter with the spark plugs removed unless the ignition system has been disabled and the engine/exhaust are cold. Fuel expelled from the cylinders can ignite by the ignition system or the hot exhaust system.

Never work on a hot engine.

Never test the ignition system without either connecting the spark plug lead to a tester or a spare grounded spark plug.

If the spark function is to be observed at the spark plug, install a spare spark plug into the open cylinder before operating the starter.

Never test the function of a fuel pump in the vicinity of a hot engine or other source of flame or combustion.

Verify that the fuel lines are correctly installed before starting the engine. See the FUEL SYSTEM section.

Be sure that the key switch is off and all electrical accessories are turned off before working on vehicle.

The battery should always be removed before performing any service or repairs that could generate sparks.

Never disconnect a circuit under load at a battery terminal.



Batteries are heavy. Use proper lifting techniques when moving them. Always lift the battery with a commercially available battery lifting device. Use care not to tip the battery when removing or installing; spilled electrolyte can cause

burns and damage.

The electrolyte in a battery is an acid solution which can cause severe burns to the skin and eyes. Treat all electrolyte spills to the body and eyes by flush-

ing with clear water. Contact a physician immediately.



Wear eye protection when working on the vehicle. In particular, be careful when working around batteries, or using solvents or compressed air.

Electrolyte spills must be neutralized with a solution of 1 tablespoon (15 ml) sodium bicarbonate (baking soda) dissolved in 1 quart (1 liters) of water and then flushed with water.

Use insulated wrenches to prevent the possibility of a dropped wrench from shorting out a battery, which could result in an explosion and severe personal injury or death.

Aerosol containers of battery terminal protectant must be used with extreme care. Insulate metal container to prevent can from contacting battery terminals which could result in an explosion.

Never work around or operate a vehicle in an environment that does not ventilate exhaust gases from the area.

Carbon monoxide is an odorless gas that is formed as a natural part of the incomplete combustion of hydrocarbon fuels. Carbon monoxide is a dangerous gas that can cause unconsciousness and is potentially lethal.

The following are symptoms of carbon monoxide inhalation:

Dizziness

Vomiting

Intense headache

Muscular twitching

Weakness and sleepiness

Throbbing in temples

If experiencing any of these symptoms, get fresh air immediately.

Read all of SAFETY and this section before attempting any procedure. Pay particular attention to Notices, Cautions, Warnings and Dangers.

BATTERY REMOVAL / INSTALLATION

Tool List	Qty.
Insulated Wrench, 1/2"	1
Socket, 1/2"	1
Extension, 12"	1
Ratchet	1
Torque Wrench, ft. lbs.	1
Battery Carrier	1

NOTICE: Hardware that is removed must be installed in its original position unless otherwise specified. If the torque values are not specified, refer to the Torque Specifications table in the GENERAL INFORMATION AND ROUTINE MAINTENANCE section.

At the battery, remove the negative (-) cable before removing the positive (+) cable. Remove the bolt from the battery hold down and remove the battery.

Installation of the battery is in reverse order of removal.

Connect the positive (+) battery cable first and then connect the negative (-) battery cable.

Be sure to remove all corrosion from the terminals and hardware. After installing the battery, coat terminals with a commercially available terminal protectant

WARNING Be careful when you use aerosol containers near battery terminals. Use an insulated container to decrease the risk of an explosion.

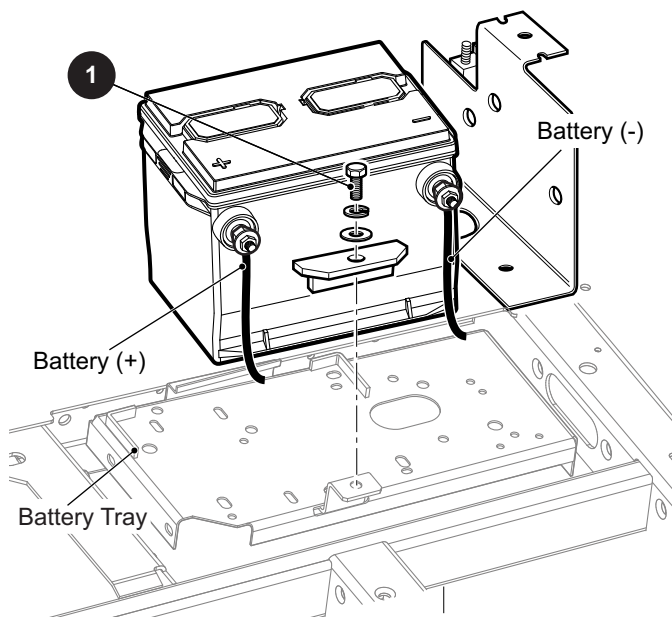

Fig. 1 Battery Removal

LIFTING THE VEHICLE

Tool List	Qty.
Floor Jack	1
Jack Stand	4
Chocks	4

WARNING To reduce the possibility of severe injury or death from a vehicle falling from a jack:

Place shifter in the P (park) position.

Always place chocks in front and behind the wheels.

Be sure the vehicle is on a firm and level surface.

Never get under a vehicle while it is supported only by a jack.

Use jack stands and test the stability of the vehicle on the stands.

The vehicle is extremely unstable during the lifting process.

When lifting the vehicle, position jacks and jack stands only on the areas indicated.

Remove payload from vehicle before lifting. No person(s) should be in or on the vehicle during the lifting process.

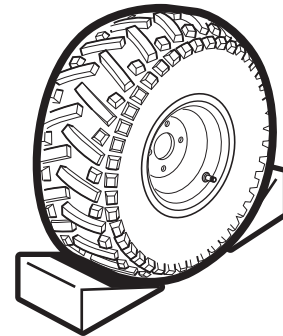

Fig. 2 Wheel Chocks

SAFETY

Read all of SAFETY and this section before attempting any procedure. Pay particular attention to Notices, Cautions, Warnings and Dangers.

Lifting Front of Vehicle

1. Chock the rear wheels to keep the vehicle from rolling backward (Ref. Fig. 2).
2. Put a jack under the center of the vehicle frame at the center of the front axle (Ref. Fig. 3).
3. Raise the vehicle with the jack.
4. Install a jack stand under each side of the vehicle frame just behind the front wheels.
5. Lower the vehicle until it rests on the jack stands.
6. Remove the jack.
7. Confirm that the vehicle is stable on the jack stands before proceeding with any service.

Lifting Rear of Vehicle

1. Chock the front wheels to keep the vehicle from rolling forward (Ref. Fig. 2).
2. Put a jack under the center of the vehicle frame at the center of the rear crossmember (Ref. Fig. 3).
3. Raise the vehicle with the jack.
4. Install a jack stand under each side of the vehicle frame just in front of the rear wheels.
5. Lower the vehicle until it rests on the jack stands.
6. Remove the jack.
7. Confirm that the vehicle is stable on the jack stands before proceeding with any service.

Lowering Vehicle

1. Make sure chocks are still in place on any wheels that remain on the ground.
2. Put the jack in the same location that was used to raise the vehicle.
3. Raise the vehicle enough to remove the jack stands. Remove the jack stands from underneath the vehicle.
4. Slowly lower the vehicle to the ground and remove the jack.

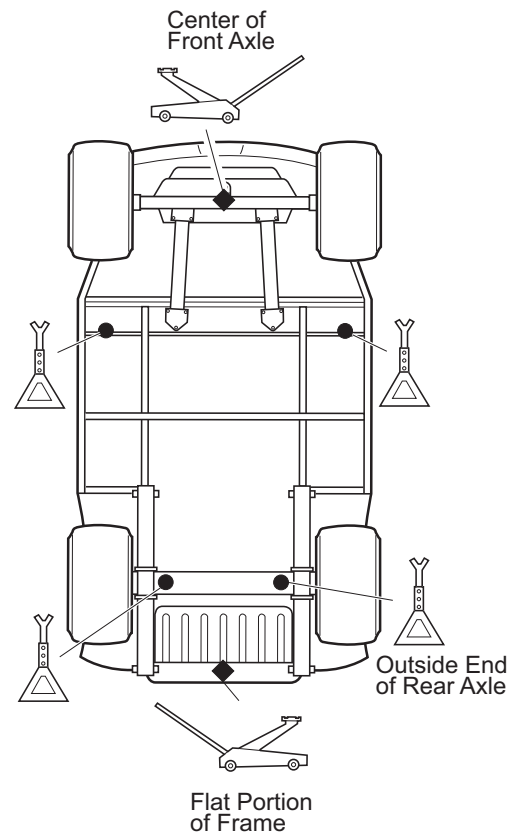

View from Underside of Vehicle

Fig. 3 Lifting the Vehicle

BODY

NOTICE: Hardware that is removed must always be installed in its original position unless otherwise specified. If the torque values are not specified, refer to the Torque Specifications table in the GENERAL INFORMATION AND ROUTINE MAINTENANCE section.

NOTICE:

GENERAL

WARNING To decrease the risk of possible injury or death from battery explosion, batteries must always be removed before any service that will generate sparks or repairs that require welding or cutting.

Use a sharp drill bit when removing the rivets on the side of the vehicle. Use extreme care when drilling out the rivets located in the front of the body and the bottom side of the body. Excessive pressure could result in the drill bit being forced through the body panel and penetrating an internal component. Put a protective piece of sheet metal between the battery and the rivet as protection. Use of a drill depth stop provides additional protection.

Body component replacement can be accomplished with a minimum of specialized tools. Most body components are held in place with conventional removable hardware. Some components are mounted with pop rivets which require the rivet head be removed in order to push out the shank of the rivet. The rivet head can be removed by drilling into the head with a **sharp** drill bit that is **slightly** larger than the shank of the rivet (Figure 1). Use care when drilling to decrease the risk of the drill bit from being forced through and damaging components located immediately behind the rivet. The best way to decrease the risk of this from occurring is to use a sharp drill bit that requires very little pressure to cut, and to place a piece of protective sheet metal between the surface being drilled and components directly behind it.

BODY COMPONENT REPLACEMENT

Body components can be replaced by removing securing hardware, replacing the component and securing with hardware in same orientation.

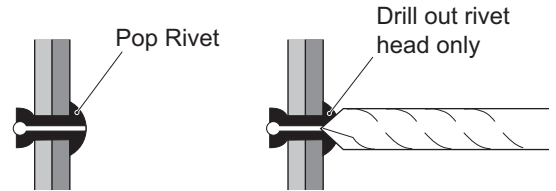

Figure 1 Drill Out Metal Rivet

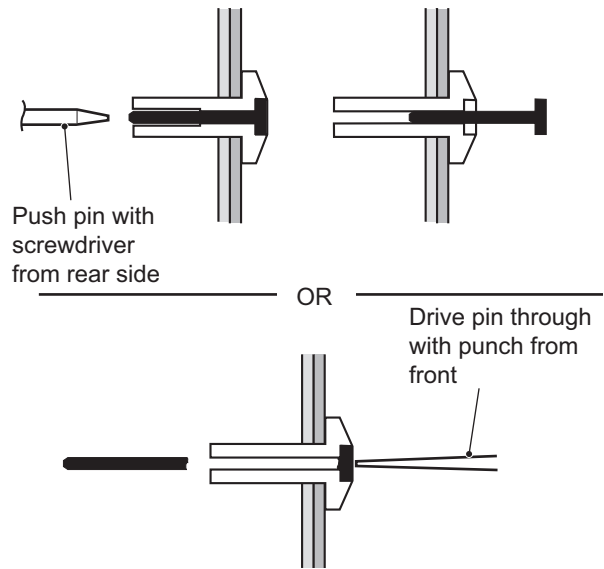

Figure 2 Drive Rivet Removal

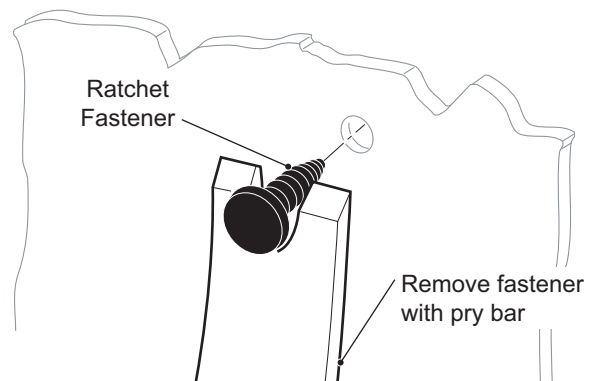

Figure 3 Remove Ratchet Fastener

BODY

Read all of SAFETY and this section before attempting any procedure. Pay particular attention to Notices, Cautions, Warnings and Dangers.

Front Body Components

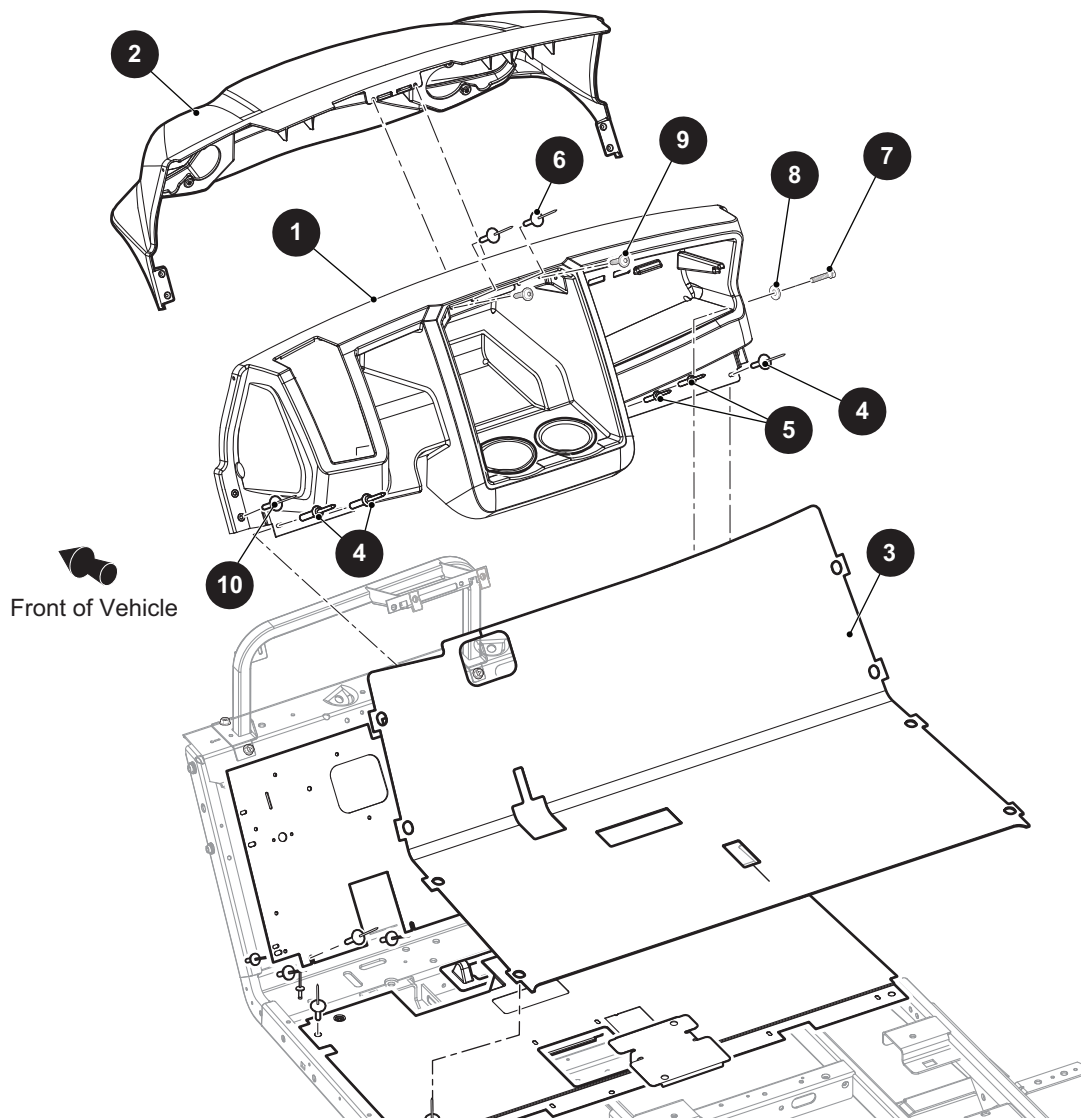

Figure 4 Front Body Components

Instrument Panel Replacement

Tool List

	Quantity
Drill	1
Drill Bit, #10	1
Wrench, 5/16"	1
Phillips Screwdriver	1
Pry Bar.....	1
Punch, Small	1
Hammer.....	1
Pop Rivet Tool	1

NOTICE: The instrument panel can be removed without removing the cowl, or may be removed as part of the cowl.

WARNING To decrease the risk of injury due to lack of vehicle information, the correct safety label must be on the instrument panel at all times. To decrease the risk of personal injury, disconnect negative (BL-) battery cables before servicing vehicle

Pull up the front edge of the floor mat (3) to expose the rivets (4) that secure the instrument panel (1) to the vehicle frame(Figure 4). Drill out the three rivets (4) that secure the instrument panel to the frame. Drill out the two rivets (6) that secure the instrument panel to the cowl (2).

Drill out the two rivets (5) and (10) that attach the instru-

Read all of SAFETY and this section before attempting any procedure. Pay particular attention to Notices, Cautions, Warnings and Dangers.

ment panel to the frame. Remove the two bolts (7), washers (8) and spacers that secure instrument panel (1) to vehicle.

Pry out two ratchet rivets (9) located within the instrument panel storage compartment. Pull the instrument panel (1) away from the cowl.

Assemble in the reverse order of removal.

Tighten the bolts (7) to the torque value specified below.

Item	Torque Specification
7	13 - 15 ft. lbs. (18 - 20 Nm)

Brush Guard Replacement

Tool List	Quantity
Socket, 1/2"	1
Ratchet	1
Torque Wrench, ft. lbs.	1

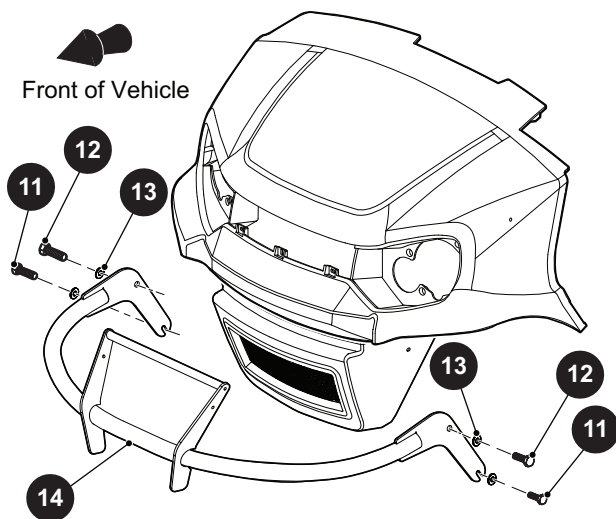

Figure 5 Brush Guard

Remove two bolts (11,12) from each side of the vehicle along with flat washers (13) that secure the brush guard (14) to the fenders. Retain the hardware for reuse (Figure 5).

Remove brush guard (14).

Assemble brush guard (14) in the reverse order of removal.

Tighten the bolts (11,12) to the torque value specified below.

Item	Torque Specification
11, 12	13 - 15 ft. lbs. (18 - 20 Nm)

Cowl Replacement

Tool List	Quantity
Drill.....	1
Drill Bit	1
Punch, Small.....	1
Pop Rivet Tool.....	1
Hammer	1

NOTICE: The cowl (2) can be removed along with the front fenders.

WARNING To decrease the risk of personal injury, disconnect negative (BL-) battery cables before servicing vehicle.

Remove the brush guard, See Brush Guard Replacement.

Drill out two rivets (6) across top of instrument panel (1) that secure the instrument panel to the cowl (2)(Figure 6).

Drill out the two rivets (15) (one per side) that secure the cowl to the instrument panel.

Lift the cowl (2) and disconnect headlights.

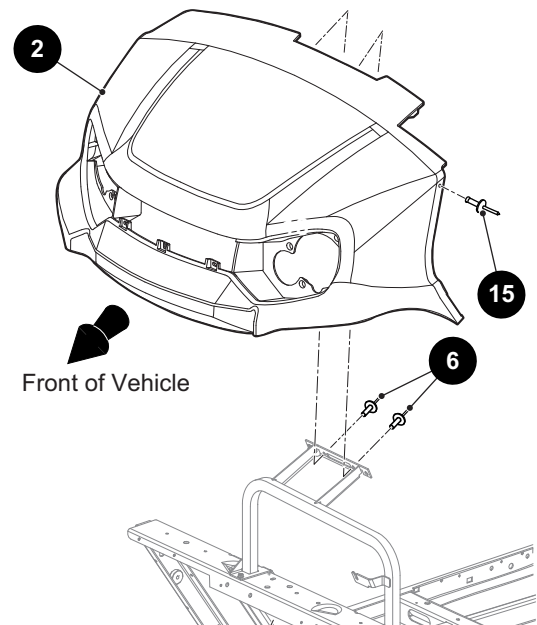

Figure 6 Cowl Replacement

Remove cowl assembly (2) from vehicle and transfer headlights to new cowl.

Cowl installation is in reverse order of disassembly.

BODY

Read all of SAFETY and this section before attempting any procedure. Pay particular attention to Notices, Cautions, Warnings and Dangers.

Front Bumper Replacement

Tool List	Quantity
Drill	1
Drill Bit	1
Punch, Small	1
Pop Rivet Tool	1
Hammer	1

NOTICE: The cowl (2) can be removed along with the front fenders.

Remove the brush guard, See Brush Guard Replacement.

Remove two bolts (17) and washers (18) from the front bumper (16). Then remove the two bolts (21) and nuts (23) from mounting bracket (22) (Figure 7).

Leave rivets (20) in place, do not remove bracket (22).

Remove the bumper (16) from the vehicle.

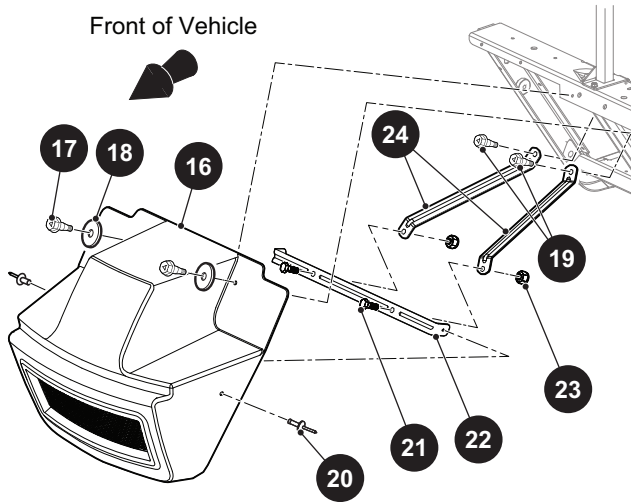

Figure 7 Front Bumper Replacement

To replace the front bumper (16) with new assembly, drill out the rivets (20) securing the front bumper (16) to the mounting bracket (22).

Assemble front bumper (16) in reverse order of removal.

Tighten the bolts (17) to the torque value specified below.

Item	Torque Specification
17	6 - 8 ft. lbs. (8.5 - 10.5 Nm)

Rocker Panel Replacement

Tool List	Quantity
Phillips Screwdriver	1
Socket, 3/8"	1
Ratchet	1
Torque Wrench, in. lbs	1

Remove two screws (15), spacers (16) and nuts (17) from top portion of rocker panel (19). Retain hardware for later installation (Figure 8).

Drill out the rivets (18) that secure the rocker panel to the vehicle frame. Remove rocker panel (19).

Repeat the steps for the other side of vehicle if necessary.

Assemble rocker panel in the reverse order of removal using new rivets (18).

Tighten nuts (17) to the torque values specified below.

Item	Torque Specification
17	45 - 55 in. lbs. (5 - 6 Nm)

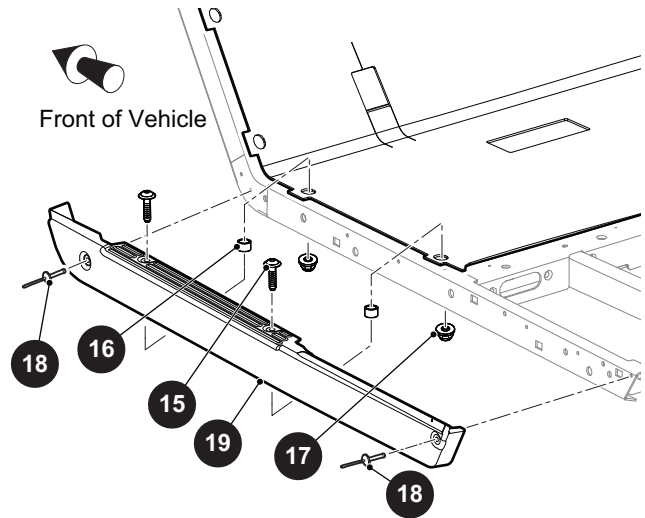

Figure 8 Rocker Panel

Side Panel Replacement

Tool List	Quantity
Drill	1
Drill Bit	1
Socket, 7/16"	1
Wrench, 7/16"	1
Pop Rivet Tool	1
Torque Wrench, ft. lbs	1

To replace either driver or passenger side panel, first remove rocker panels. See Rocker Panel Replacement.

Remove two ratchet rivets (24) securing side panel (22) to

Read all of SAFETY and this section before attempting any procedure. Pay particular attention to Notices, Cautions, Warnings and Dangers.

rear fender (Figure 9). Remove the hardware (28) from five clips that secure the side panel to the front panel and rear fender. Retain hardware for later installation.

Drill out the rivets (25) securing side panel to the frame. Remove bolt (29) and nut (30) securing seat support panel (27) to the frame.

Remove side panel (22) from vehicle. Install side panel (22) in the reverse order of removal.

Tighten the nuts (30) to the torque value specified below.

Item	Torque Specification
30	14 - 18 ft. lbs. (19 - 24 Nm)

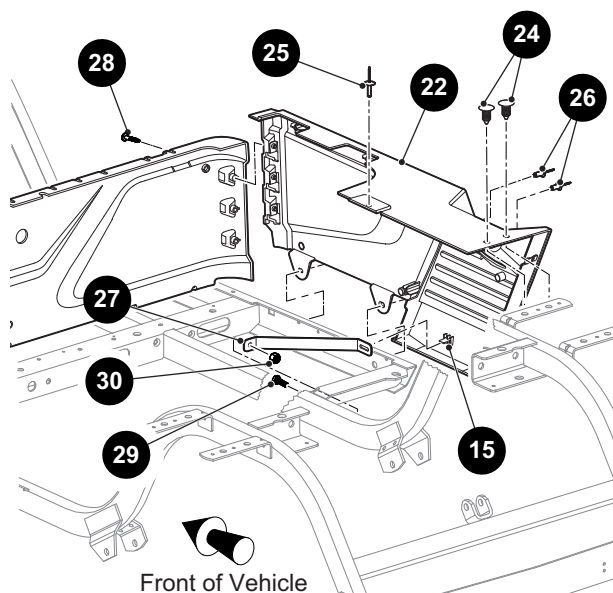

Figure 9 Side Panel

Seat Filler Panel Replacement

Tool List	Quantity
Drill	1
Drill Bit	1
Pop Rivet Tool	1

Remove screws (33) securing seat filler panel (31) to side panel (22) (Figure 10).

Remove seat filler panel (31).

Install seat filler in reverse order of removal.

Tighten the screws (33) to the torque value specified below.

Item	Torque Specification
33	13 - 18 in. lbs. (1.5 - 2 Nm)

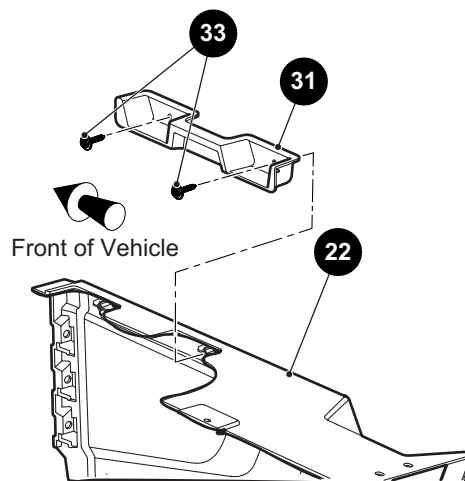

Figure 10 Seat Filler Panel

Rear Body Panel Replacement

Tool List	Quantity
Socket, 7/16"	1
Ratchet	1
Wrench, 7/16"	1

Remove two rivets (37) from each side securing the rear body panel (40) to the rear fenders (35, 36) on each side (Figure 11).

Remove two ratchet fasteners (41) securing the rear body panel (40) to the frame. Retain the ratchet fasteners (41) for installation.

Remove the rear body panel (40) from vehicle.

Install rear body panel (40) in the reverse order of removal using new rivets (37).

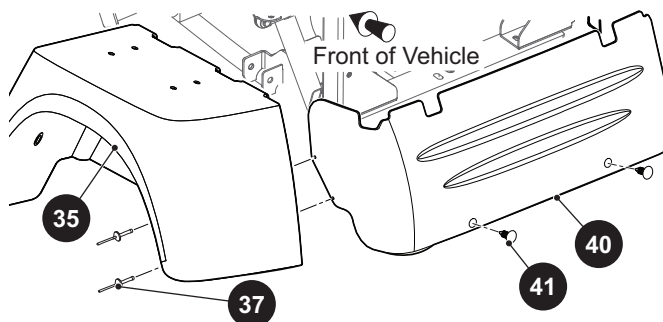

Figure 11 Rear Body Panel Replacement

BODY

Read all of SAFETY and this section before attempting any procedure. Pay particular attention to Notices, Cautions, Warnings and Dangers.

Rear Fender Replacement

Tool List	Quantity
Socket, 7/16"	1
Ratchet	1
Wrench, 7/16"	1
Drill	1
Drill Bit	1
Pry Bar	1
Pop Rivet Tool	1
Torque Wrench, ft. lbs.	1

Remove the side panels. See Side Panel Replacement. Page 22.

Disconnect the taillight leads from the wiring harness and remove the taillight from the fender (35 or 36).

Drill out two rivets (37) securing the rear fender (35 or 36) to the rear body panel (Figure 13).

Remove two bolts (38) securing rear fender (35 or 36) to the side panel.

Remove four ratchet fasteners (39) from top of rear fender (35 or 36) and remove fender from vehicle.

Install rear fender (35 or 36) in the reverse order of removal using new rivets (37).

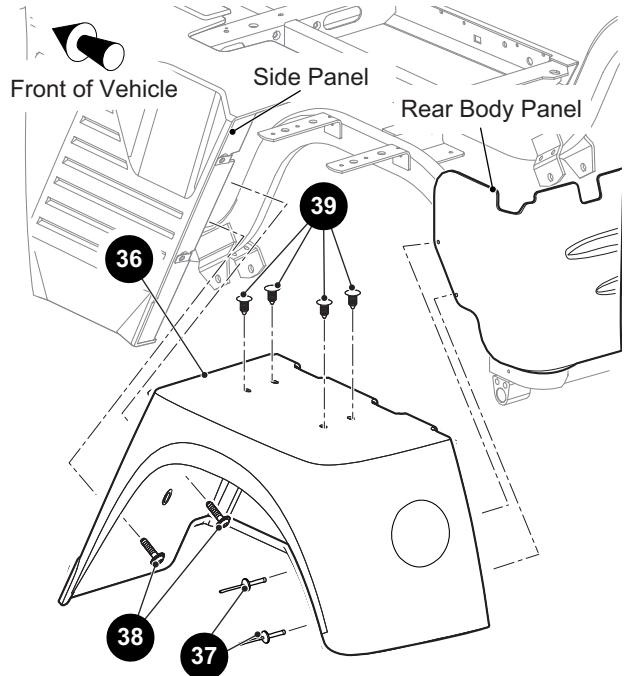

For Vehicles Manufactured After July 25, 2021

Figure 13 Rear Fender Replacement.

Item	Torque Specification
38	25 - 40 in. lbs. (3 - 4.5 Nm)

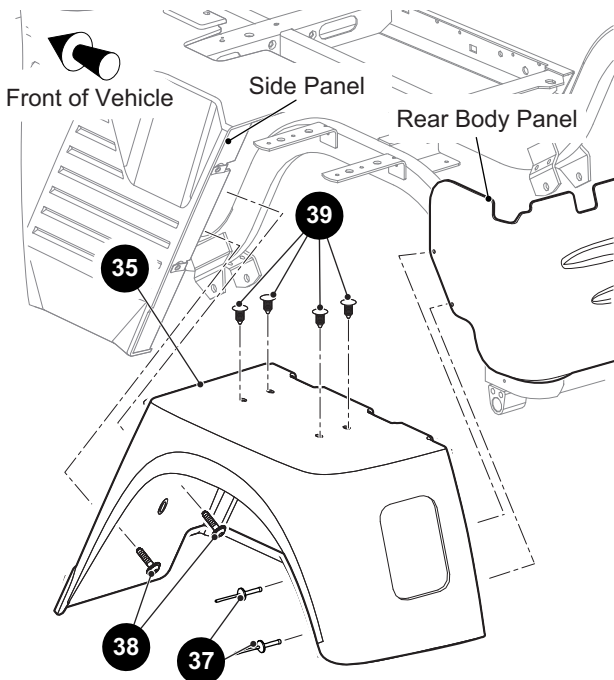

For Vehicles Manufactured Before July 25, 2021

Figure 12 Rear Fender Replacement.

PAINTING

Follow the paint manufacturer's recommendations for specific painting procedures and information.

WARNING All painting must be done in an area with adequate ventilation to safely disperse harmful vapors.

Wear eye protection and respirator, to protect from over spray and airborne mist.

NOTICE: Provide protection from over spray to vehicle and surrounding area.

Minor Scratches

To repair minor scratches, the manufacturer of the Durashield™ body panels recommends the following steps be taken:

1. Thoroughly clean the surface to be repaired with alcohol, and allow to dry.
2. Use a brush to apply a minimum of two coats of touch up paint to damaged area. Allow 30 - 45 minutes between coats; increase to 45 - 60 minutes in higher humidity. The painted area should be slightly above the surface of the part.

Read all of SAFETY and this section before attempting any procedure. Pay particular attention to Notices, Cautions, Warnings and Dangers.

3. Use 400 grit "wet" sand paper to blend painted area level with the surface of the part being repaired.
4. Use a polishing compound (3M Finesse or automotive grade) to renew gloss and to further blend and transition newly painted surface.
5. Clean with alcohol, and allow to dry.
6. (Optional but recommended) Apply clear coat to renew and protect depth of finish.
7. Wax or polish with Carnauba base product, available at any automotive parts distributor. Do not wax flat finishes.

base color coat, and a clear coat.

Most paint manufacturers can perform a computer paint match to assure accurate color matching.

Larger Scratches

To repair large scratches, the manufacturer of the Durashield™ body panels recommends the following steps be taken:

1. Thoroughly clean the surface to be repaired with alcohol, and allow to dry.
2. Apply tape to area surrounding damaged area to prevent over spray of paint.
3. Shake the aerosol touch up paint a minimum of one minute to mix thoroughly and achieve the best color match.
4. Apply paint in light, even, overlapping strokes. Multiple coats can be applied to provide adequate coverage and finish.
5. Allow paint to dry overnight.
6. Use 400 grit "wet" sand paper to blend painted area level with the surface of the part being repaired.
7. Use a polishing compound (3M Finesse or automotive grade) to renew gloss and to further blend and transition newly painted surface.
8. Clean with alcohol, and allow to dry.
9. (Optional but recommended) Apply clear coat to renew and protect depth of finish.
10. Wax or polish with Carnauba base product, available at any automotive parts distributor. Do not wax flat finishes.

Complete Panel Repair

In situations where large panels or areas must be painted, touch up paint is not recommended. In such cases professional painting or panel replacement is necessary. Body panel replacement is sometimes more cost effective than painting. If the decision to paint is chosen, it can be accomplished by any body panel repair shop with experience in painting thermoplastic elastomer (TPE) panels. TPE is a common material in modern automobile body panels, and all body panel repair shops should be familiar with the materials and processes required.

The finish will include an application of a primer coat, a

BODY

Read all of SAFETY and this section before attempting any procedure. Pay particular attention to Notices, Cautions, Warnings and Dangers.

Read all of SAFETY and this section before attempting any procedure. Pay particular attention to Notices, Cautions, Warnings and Dangers.

TRUCK BED

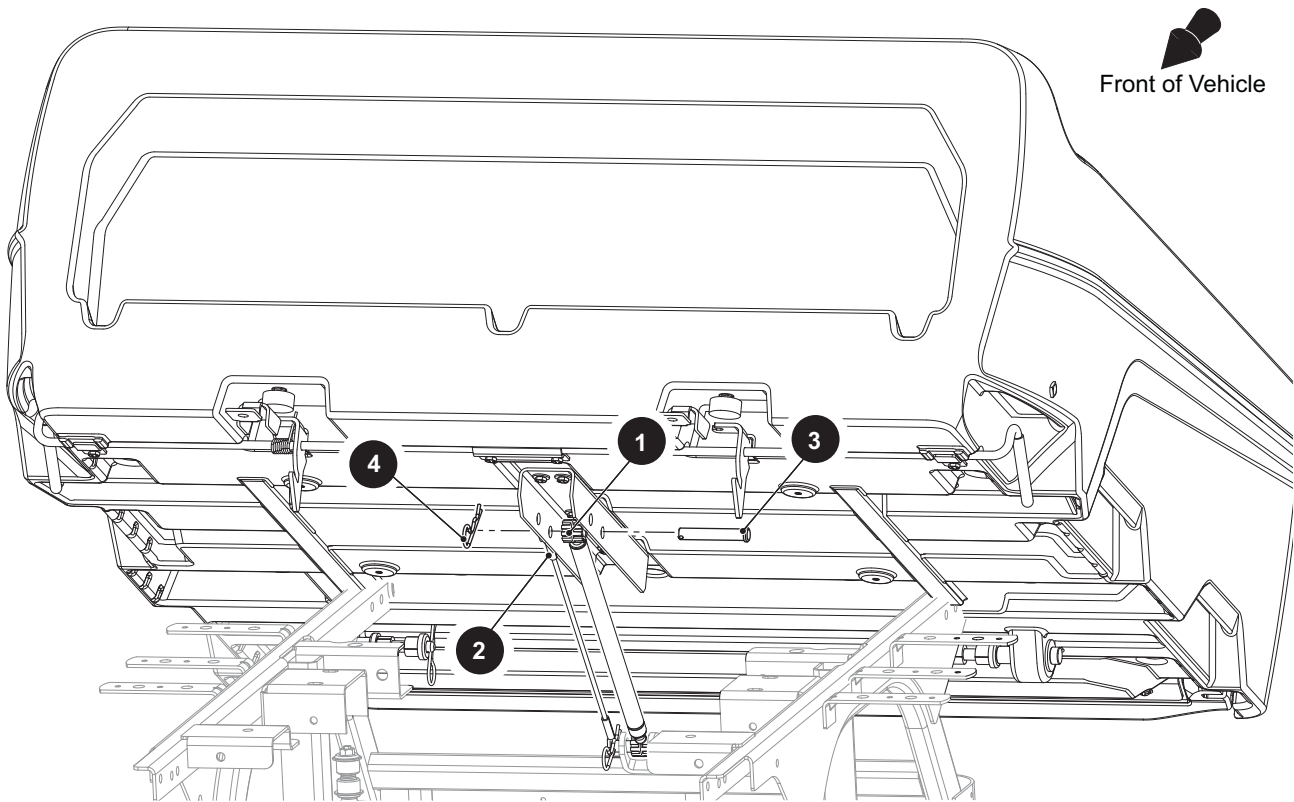

Figure 1 Truck Bed Replacement

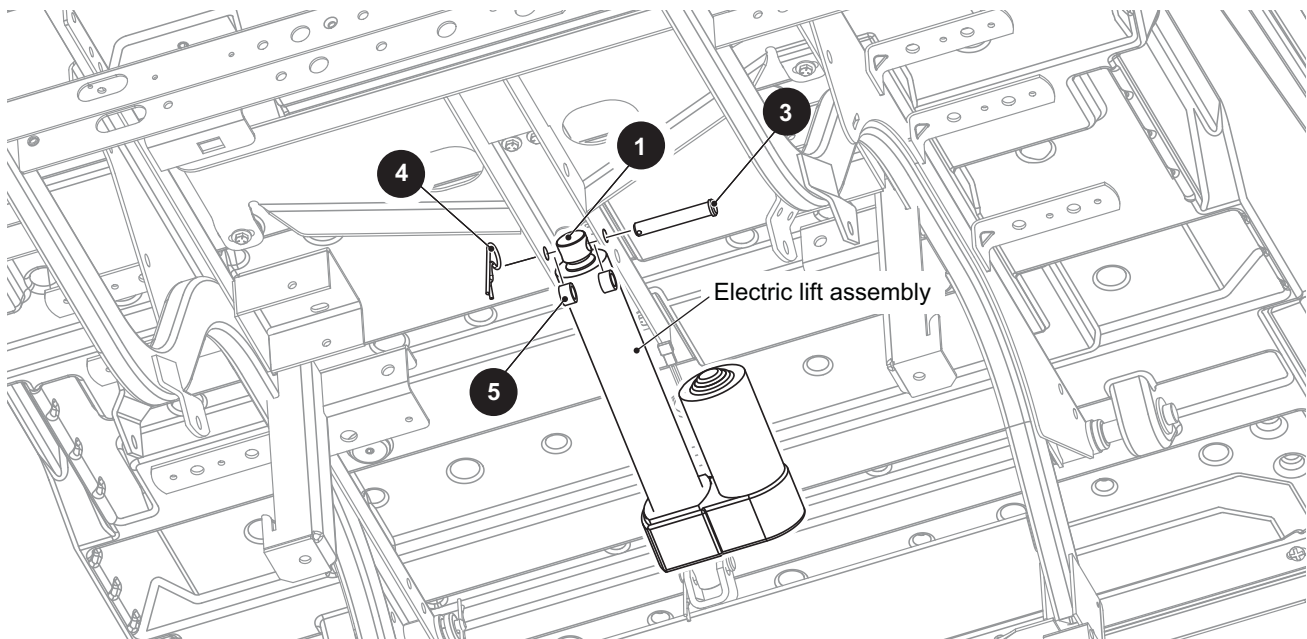

Figure 2 Truck Bed Replacement (Optional Electric Lift)

TRUCK BED

Read all of SAFETY and this section before attempting any procedure. Pay particular attention to Notices, Cautions, Warnings and Dangers.

TRUCK BED REMOVAL

Tool List	Quantity
Back Brace	2
Needle Nose Pliers	1

WARNING *The truck bed is heavy and difficult to handle. To prevent possible personal injury, it is strongly recommended that an assistant or adequate lifting device be used to remove the truck bed from the vehicle.*

To remove the bed from the vehicle:

1. Release the bed latch or activate the electric bed lift and lift the truck bed until the gas spring is fully extended.
2. With a person on each side of the bed, remove the cotter pin (3) and clevis pin (4) that connect the gas spring (1) to the truck bed (Figure 1). If the optional electric lift is installed, remove and retain spacers (5) (Figure 2).
3. Rotate the gas spring (1) and bed tether cable (2) down to sit on the bracket. Lower the truck bed.
4. Remove the cotter pins (12) and clevis pins (13) from both sides of the truck bed (Figure 3) (Figure 4).
5. If the vehicle is equipped with the standard plastic bed, retain the flat washers (14), spacers (15) and pivot bushings (16) (Figure 3).
6. If the vehicle is equipped with the aluminum bed, retain the pivot bushings (16) (Figure 4).
7. Remove the bed from the vehicle.
8. Install the truck bed in the reverse order of disassembly.

NOTICE: *Make sure the pivot bushings are in place before installing the bed.*

NOTICE: *Make sure the pivot bushings are in place before installing the bed.*

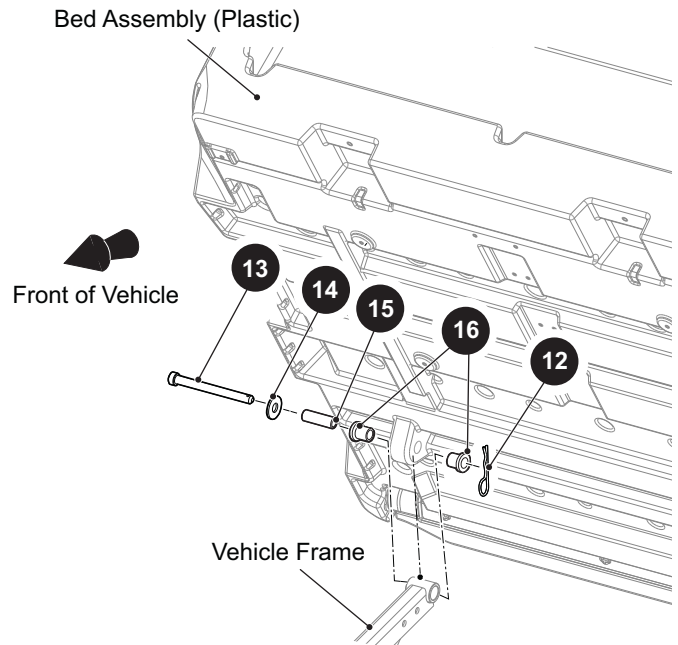

Figure 3 Truck Bed Assembly (Plastic)

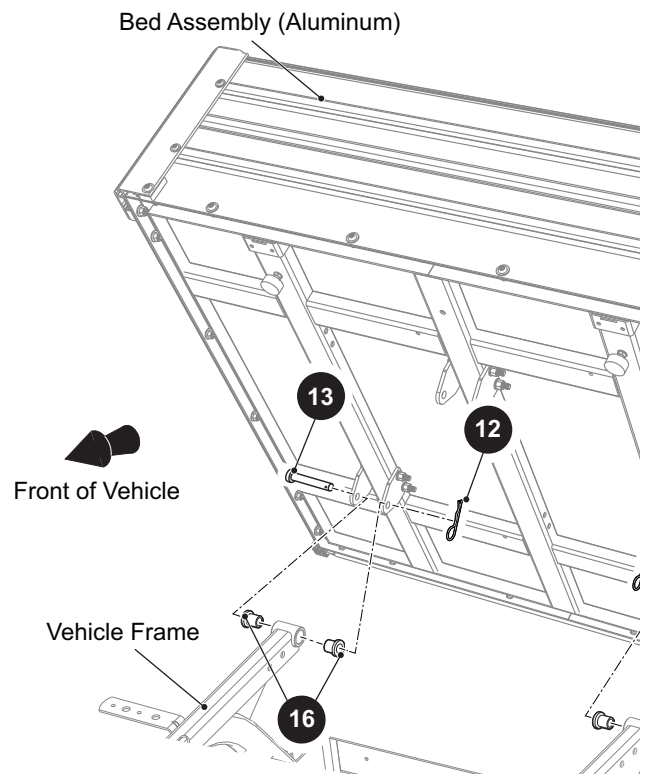

Figure 4 Truck Bed Assembly (Aluminum)

SPEED CONTROL

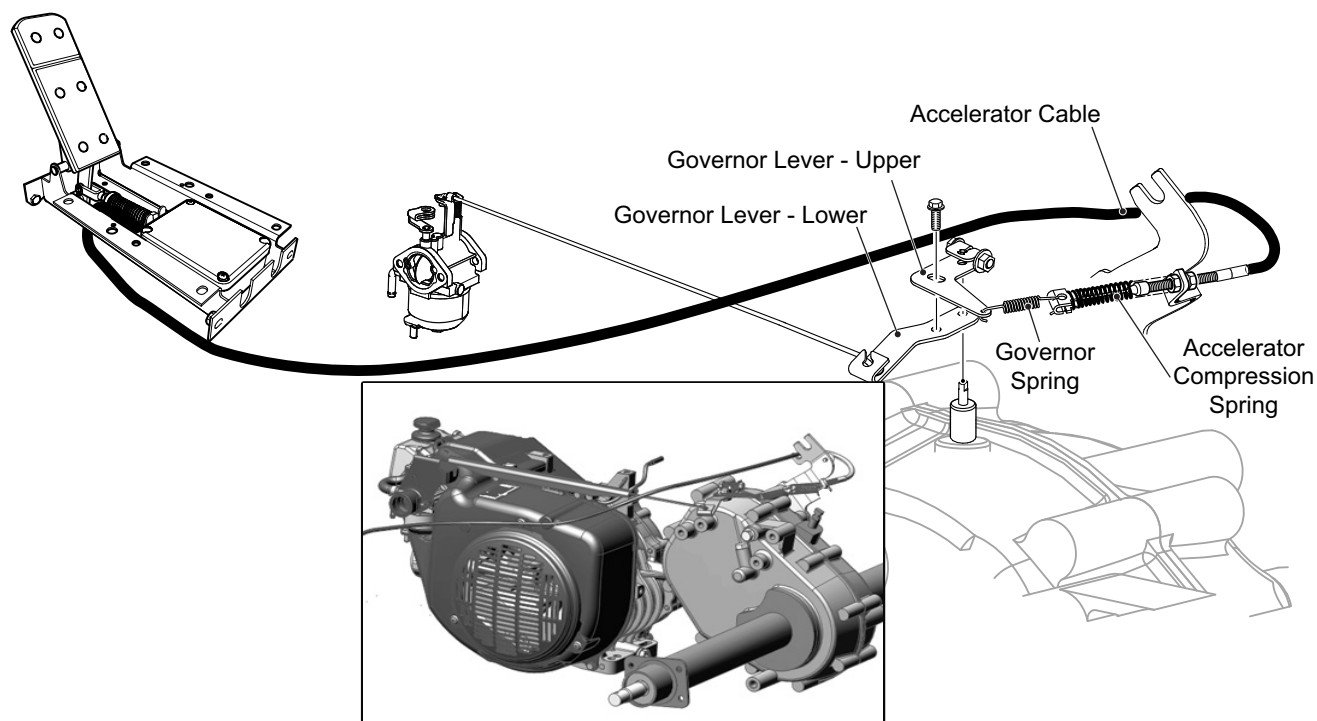

Fig. 1 Accelerator and Speed Control System

NOTICE: The linkages that control the accelerator mechanism and governor are designed to operate as an integrated assembly. Any adjustment to one portion of the system will have an effect on the other components within the system.

Hardware that is removed must be installed in its original position unless otherwise specified. If the torque values are not specified, refer to the Torque Specifications table in the GENERAL INFORMATION AND ROUTINE MAINTENANCE section.

WARNING

To decrease the risk of possible injury or death, follow the lifting procedure in SAFETY section of this manual. Place wheel chocks in front and behind the rear wheels. Check the stability of the vehicle on the jack stands before starting any repair procedure. Never work on a vehicle that is supported by a jack alone.

SYSTEM OPERATION

Pedal Box Operation

When you press the accelerator, the accelerator rod moves towards the rear of the vehicle by overcoming the resistance of the accelerator return spring (Ref. Fig. 1).

As the accelerator pedal moves, the parking brake is released, the micro switch closes and activates the ignition circuit.

The rear end of the accelerator rod is joined to the micro switch cam which connects to the accelerator cable.

As the micro switch cam moves to the rear it pulls the accelerator cable, which pulls against the governor spring.

When the accelerator cable pulls against the accelerator cable/governor spring, the spring extends until it overcomes the resistance exerted by the governor mechanism. As the governor spring overcomes these forces, the governor arm moves and the motion is transferred through linkage rod to the throttle plate.

Governor Operation

Until the vehicle reaches its governed speed, the vehicle will continue to accelerate in relation to the accelerator pedal position.

When governed speed is reached, the ground speed governor in the rear axle assembly operates against the accelerator cable/governor spring and closes the throttle lever until correct governed speed is achieved (Ref. Fig. 1).

It is the force of the accelerator cable/governor compression spring in response to accelerator pedal and governor lever (7) position that controls the position of the throttle plate.

The compression spring provides cushioning of sudden changes in throttle linkage position to provide smooth power transmission.

SPEED CONTROL

Read all of SAFETY and this section before attempting any procedure. Pay particular attention to Notices, Cautions, Warnings and Dangers.

⚠ WARNING

Driving above governed speed could cause a loss of vehicle control and possible injury or death.

Tampering with or adjusting the governor or other speed control components will void the warranty.

FAULT TESTING

Erratic acceleration and performance that does **not** include a notable increase in governed speed, can indicate the need for a linkage adjustment.

Symptoms that include an increase in governed speed indicate:

- A possible governor failure within the rear axle
- Worn components in the governor system
- Improper adjustment of linkage system

NOTICE: Other factors can affect the performance characteristics of the vehicle but they must be investigated only after you confirm the linkage adjustment.

SPEED CONTROL

Tool List

	Qty.
Phillips Screwdriver	1
Flat Blade Screwdriver	1
Needle Nose Pliers	1
Slip Joint Pliers	1
Open End Wrench, 10 mm	2
Ratchet	1
Socket, 15 mm	1
Torque Wrench, in. lbs.	1
Torque Wrench, ft. lbs.	1
Drill, 1/4"	1
Drill Bit, 3/16"	1
Pop Rivet Tool	1

⚠ WARNING

Remove the negative (-) battery cable from the battery to prevent the vehicle from moving and possible personal injury that may

result. Refer to SAFETY section of this manual for additional cautions and warnings.

NOTICE: Be sure to follow the sequence indicated when making linkage adjustments.

Accelerator Cable Removal at Governor

To remove the accelerator cable (9) from the governor, loosen the nuts (13) securing the cable to the accelerator cable bracket (14) at the rear axle and unhook the spring from the upper governor lever (15).

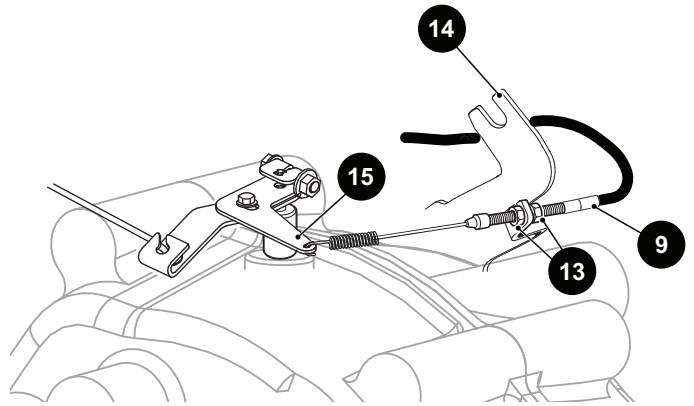

Fig. 2 Accelerator Cable at Governor

Tighten the hardware to the torque value specified below.

Item	Torque Specification
13	35 - 44 in. lbs. (4 - 5 Nm)

Accelerator Cable Removal at Pedal Box

To access the micro switch, remove the rocker panel (4) (see 'Rocker Panel Replacement' in BODY section), lift the floor mat (5) and remove the access cover (6) from the floor. Remove the screws (7) and cover (8) from the pedal box.

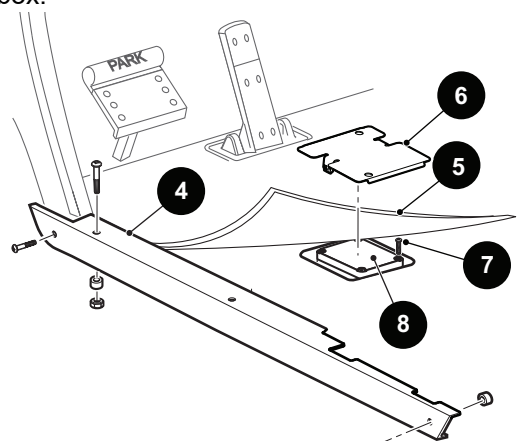

Fig. 3 Pedal Box Access

To remove the accelerator cable socket from the accelerator pedal box (11), remove the box cover (8) and unsnap the cable end (9) from the micro switch cam (10). With a pair of pliers, pinch the cable fitting to compress the sides enough to push the cable fitting through the accelerator pedal box.

SPEED CONTROL

Read all of SAFETY and this section before attempting any procedure. Pay particular attention to Notices, Cautions, Warnings and Dangers.

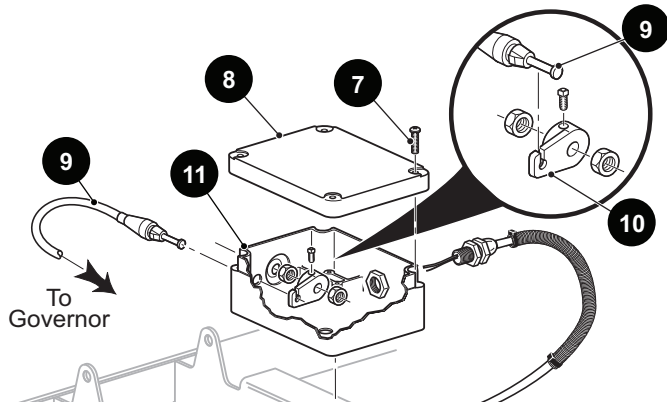

Fig. 4 Accelerator Cable at Pedal Box

Accelerator Cable Installation

To install the accelerator cable, proceed in reverse order of removal (Ref. Fig. 2) (Ref. Fig. 3) (Ref. Fig. 4).

Tighten the hardware to the torque value specified below.

Item	Torque Specification
7	6 - 8 in. lbs. (0.6 - 0.9 Nm)
13	35 - 44 in. lbs. (4 - 5 Nm)

Accelerator Cable Adjustment

To adjust the accelerator cable, position the cable in the accelerator cable bracket at the rear axle so that the throttle is fully closed while allowing 1" travel at the top of the accelerator pedal. Once you correctly position the cable, tighten the cable securing nuts (13) on the bracket (Ref. Fig. 2).

Throttle Rod Removal

To remove the throttle rod from the throttle plate (Ref. Fig. 5), twist the plastic connector (1) counterclockwise away from the throttle rod. Line up the slot with the tabs on the rod. Remove the rod from the throttle lever by lifting up (2).

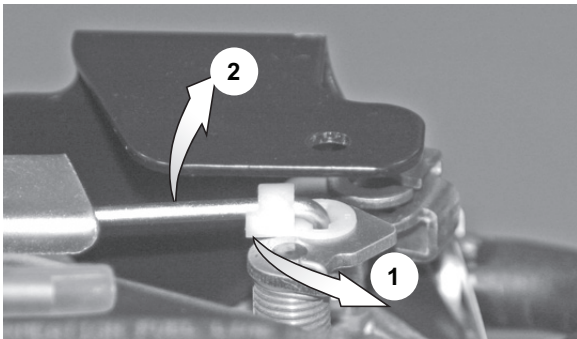

Fig. 5 Throttle Rod Removal

Throttle Rod Adjustment

To adjust the throttle rod (17), loosen the bolt (18) between the two governor levers and rotate lower governor lever (19) counter-clockwise until the throttle plate is fully open. Rotate upper governor lever (20) counter-clockwise until it stops. Tighten bolt that locks the governor levers in position to the torque value specified below.

Item	Torque Specification
18	60 - 72 in. lbs. (7 - 8 Nm)

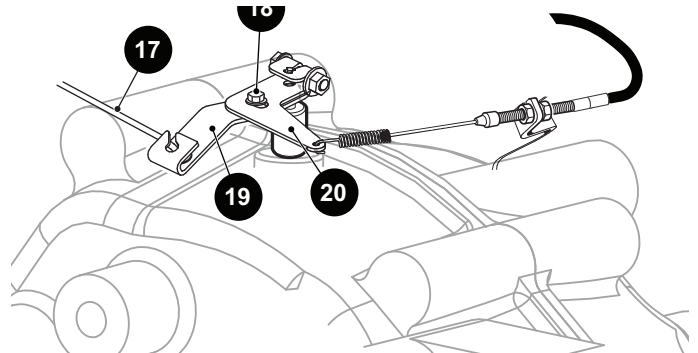

Fig. 6 Throttle Rod Adjustment

PEDAL BOX ADJUSTMENTS

Tool List

Tool List	Qty.
Needle Nose Pliers	1
Phillips Screwdriver	1
Open End Wrench, 9/16"	1
Open End Wrench, 1/2"	1
Open End Wrench, 7/16"	1
Open End Wrench, 3/8"	1
Allen Wrench, 1/8"	1

NOTICE: If any adjustments are made in the pedal box or accelerator area, it is necessary to perform the speed control cable adjustment again. Any adjustment made in the pedal box or accelerator area will affect the cables.

Accelerator Pedal Arm Adjustment

Lift the front of the vehicle using the procedures and safety information in the SAFETY section.

Confirm the accelerator pedal arm (1) contacts the accelerator pedal bracket (2) when in the released position (Ref. Fig. 7). If there is no contact, loosen the jam nut (3) and rotate the rod (4) until contact is made.

SPEED CONTROL

Read all of SAFETY and this section before attempting any procedure. Pay particular attention to Notices, Cautions, Warnings and Dangers.

NOTICE: Note that the factory applies a thread sealant to the accelerator rod threads before threading the rod into the clevis.

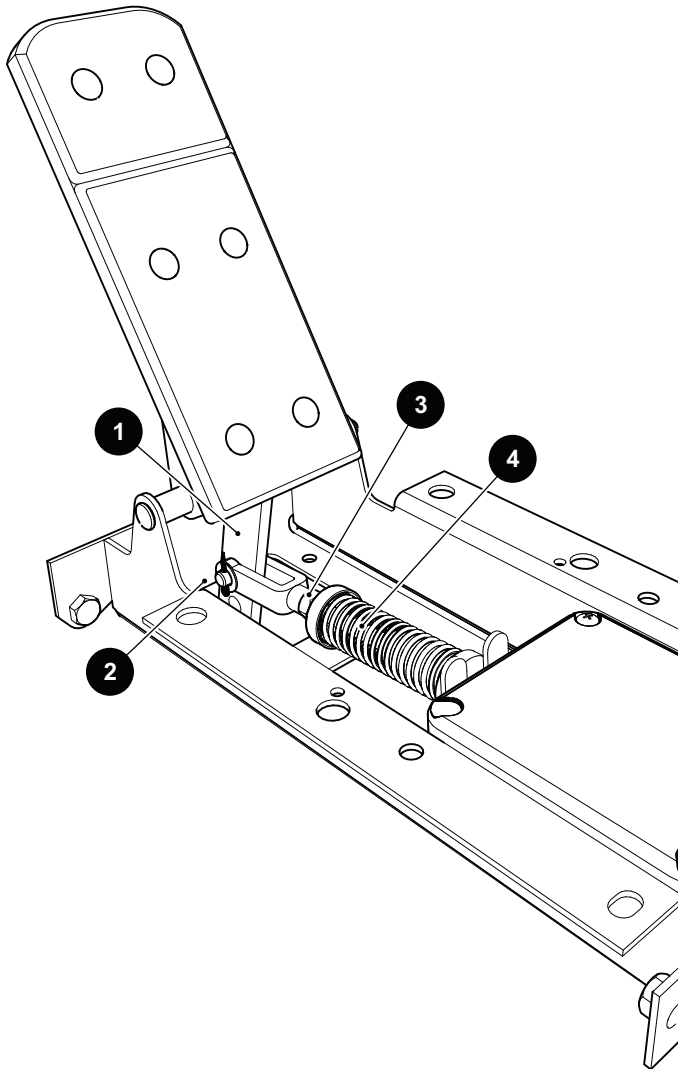

Fig. 7 Accelerator Pedal Arm Adjustment

Micro Switch Adjustment

When the system is in correct adjustment, the micro switch in the accelerator pedal box will click when the top of the accelerator pedal moves approximately 1/2" - 5/8" (13 - 16 mm). The accelerator cable (as seen at the rear axle) must have some slack present and not show any movement until after the micro switch clicks.

To access the micro switch, remove the rocker panel, lift the floor mat and remove the access cover from the floor (Ref. Fig. 3). Remove the screws (8) and cover (7) from the pedal box (Ref. Fig. 8).

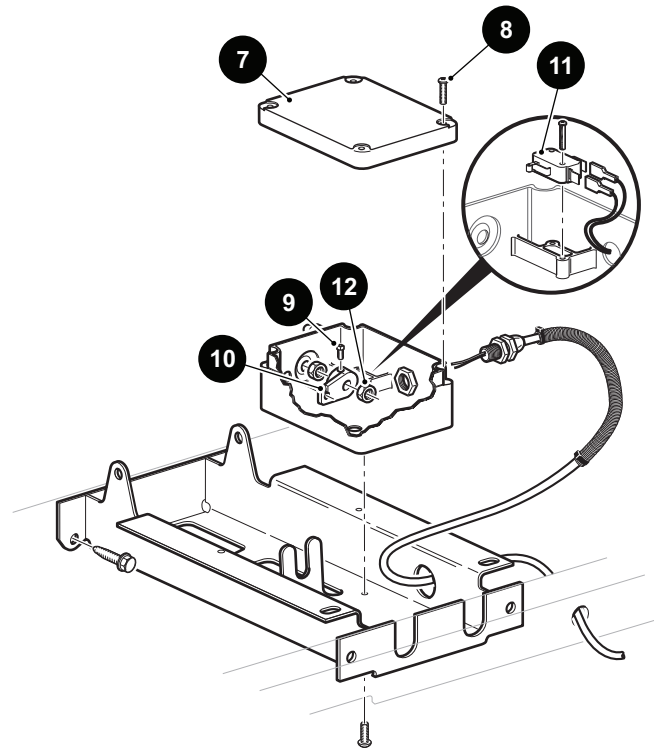

Fig. 8 Pedal Box Micro Switch

Loosen the setscrew (9) in the cam (10) using a 1/8" Allen wrench. Loosen the jam nut (12) and move the cam to adjust as needed (Ref. Fig. 8). Adjust to permit 1/2" - 5/8" (13 - 16 mm) of accelerator pedal travel before the micro switch (11) clicks. Measure the distance at the top of the pedal with the pedal arm contacting the pedal bracket. Make sure the setscrew in the cam does not contact the micro switch actuator.

Tighten the set screw (9) and the jam nut (12) to the torque value specified below.

Item	Torque Specification
9	45 - 55 in. lbs. (5 - 6 Nm)
12	10 - 11 ft. lbs. (14 - 15 Nm)

Make sure the accelerator pedal moves smoothly and the accelerator cable pulls smoothly on the governor arm.

Replace the cover on the pedal box. Tap lightly to set the cover before installing screws. Replace the access cover on the floor. Replace floor mat and rocker panel.

Road Test

Connect the negative (-) battery cable to the battery.

Test drive the vehicle and confirm that the compression spring adjustment results in the maximum governed

SPEED CONTROL

Read all of SAFETY and this section before attempting any procedure. Pay particular attention to Notices, Cautions, Warnings and Dangers.

speed specified in the GENERAL SPECIFICATIONS section.

Determine the speed by measuring the time it takes to travel a known set distance with the vehicle at maximum speed.

Enter the time and distance into this formula to calculate speed:

- Rate (in MPH) = (Distance in feet ÷ 5280) / (Time in seconds ÷ 3600)
- Rate (in KPH) = (Distance in meters ÷ 1000) / (Time in seconds ÷ 3600)

For example:

- $(300 \text{ ft.} \div 5280) / (13.6 \text{ sec.} \div 3600) = 15 \text{ MPH}$
- $(100 \text{ m} \div 1000) / (15 \text{ sec.} \div 3600) = 24 \text{ KPH}$

If the speed is not within the specified speed range, stop the vehicle and adjust the governor compression spring as described in procedure above.

Tightening the spring results in a speed increase, while loosening it will result in a speed decrease.

Repeat the test and adjustment until the factory recommended governed speed is achieved.

Install a new safety seal on the governor after calibrating the vehicle.

SPEED CONTROL

Read all of SAFETY and this section before attempting any procedure. Pay particular attention to Notices, Cautions, Warnings and Dangers.

WEATHER PROTECTION

GENERAL

⚠ WARNING *The canopy does not provide protection from roll over or falling objects.*

The windshield does not provide protection from tree limbs or flying objects.

The canopy and windshield are designed for weather protection only.

Clean the windshield with water and a clean cloth. Minor scratches can be removed with a commercial plastic polish or Plexus plastic cleaner available from the service parts department.

Transporting Vehicle

If the vehicle is to be transported on a trailer at highway speeds, the windshield and top must be removed and the seat bottoms secured. Always check that the vehicle and contents are adequately secured before transporting the vehicle.

⚠ WARNING *To decrease the risk of personal injury to occupants of other highway vehicles, be sure that the vehicle and contents are secured to trailer.*

Do not ride on vehicles being transported.

Remove the windshield before transporting.

Maximum speed with canopy installed is 50 mph (80 kph).

CANOPY TOP

Tool List	Quantity
Plastic Faced Mallet	1
Wrench, 1/2"	2
Wrench, 9/16"	2
Hex Wrench, 7/32"	1
Straight Blade Screwdriver	1

Front Strut Installation

1. Remove and discard the four bolts from the front cowl (See Detail A).
2. Upper Hole: Install the front strut (1) with bolt (2), lock washer (3), and flat washer (4) outside of the strut with the spacer (5) and flat washer (4) between the front cowl and strut. *If a brush guard (6) is to be installed you will add a spacer (5) between the brush guard and the strut.*
3. Lower Hole: Install the strut with bolt (2), lock washer (3), and flat washer (4) outside of the strut with the a

flat washer (4) between the front cowl and strut. *If a brush guard (6) is to be installed you will add a spacer (5) between the brush guard and the strut.*

Tighten the hardware to the torque values specified below.

Item	Torque Specification
2	13 - 15 ft. lbs. (17 - 20 Nm)

Rear Support Installation

1. At driver side of vehicle, align the holes in the rear strut (7) with the holes in the seat back support bracket. (See Detail D) (Figure 1).
2. Insert bolt (8) through the rear strut and seat back support bracket.
3. Secure with flat washer (9) and lock nut (10) on the inside of seat support bracket (Figure 1). *Finger tighten hardware to allow for adjustment.*
4. Repeat procedure with rear strut at passenger side of vehicle.

Tighten the hardware to the torque values specified below after installing the canopy top.

Item	Torque Specification
8	13 - 15 ft. lbs. (17 - 20 Nm)

Canopy Top Installation

1. Place canopy top (11) onto struts (See Detail B and C).
2. Secure canopy top loosely with bolts (12), washers (13), spacers (14) and lock nuts (15). *Finger tighten hardware to allow for adjustment.*

Tighten the hardware to the torque values specified below.

Item	Torque Specification
12	3 - 5 ft. lbs. (4 - 6 Nm)

WEATHER PROTECTION

Read all of SAFETY and this section before attempting any procedure. Pay particular attention to Notices, Cautions, Warnings and Dangers.

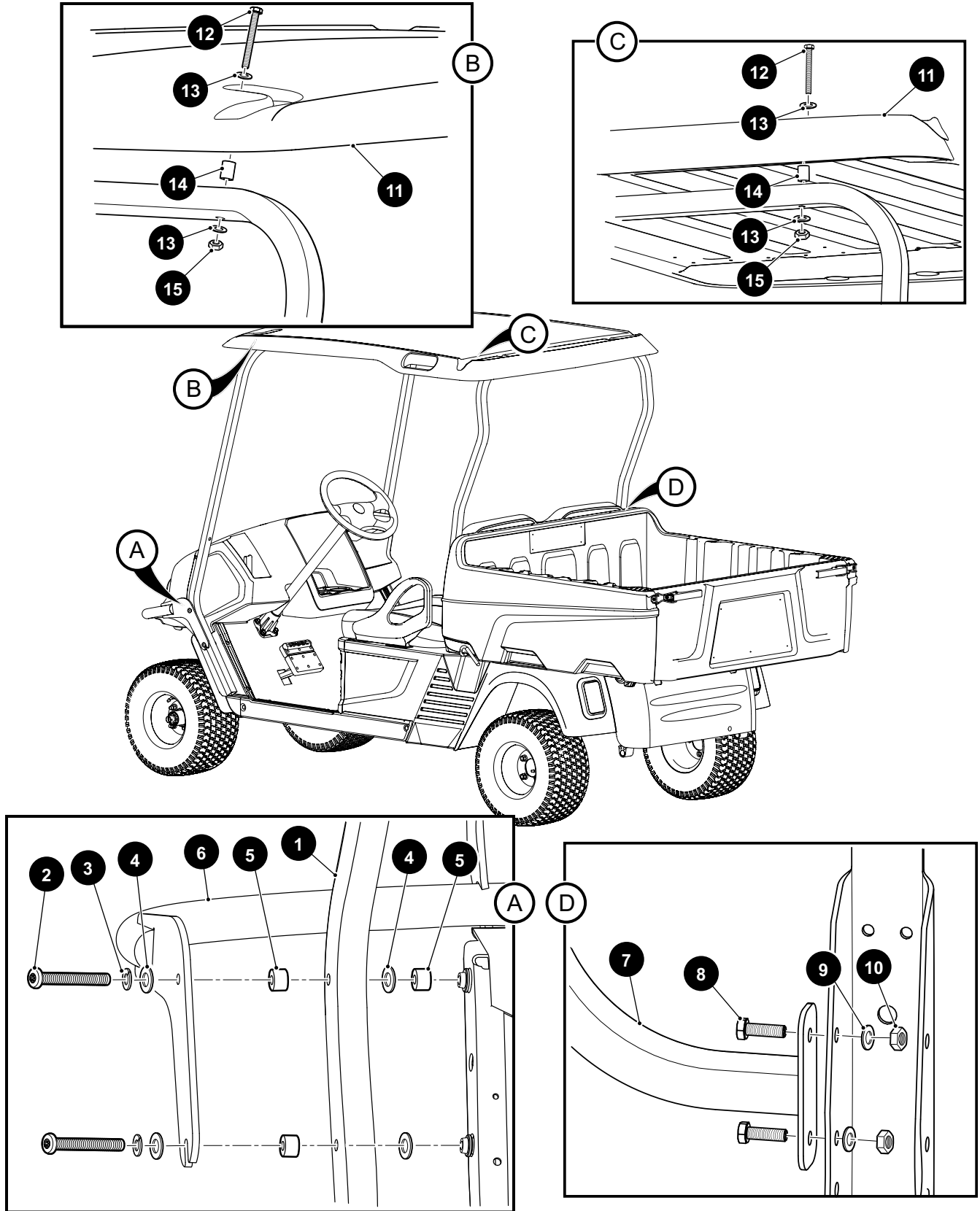

Figure 1 Canopy Top

WEATHER PROTECTION

Read all of SAFETY and this section before attempting any procedure. Pay particular attention to Notices, Cautions, Warnings and Dangers.

FLAT WINDSHIELD

Tool List	Quantity
Rubber Mallet	1
Torx Plus Bit, 45 IP	1
Ratchet	1
Socket, 15mm	1
Torque Wrench, in. lbs.	1

1. Attach the bulb seal (16) to the bottom edge of the windshield assembly (17).
2. Carefully tap each windshield sash (18) onto the windshield. Pay careful attention to the orientation of each sash.
3. Install the windshield fastener grommets (19) to the windshield assembly (17).

4. Orient the windshield assembly (17). Align each windshield fastener grommet (19) with the mounting hole in each strut, and clip the sashes (18) to the canopy struts.
5. Insert torx bolts (20) through each windshield fastener grommet (19) and strut leg, secure with lock nuts (21).

Tighten the hardware to the torque values specified below.

Item	Torque Specification
20	70 - 97 in. lbs. (7.9 - 10.9 Nm)

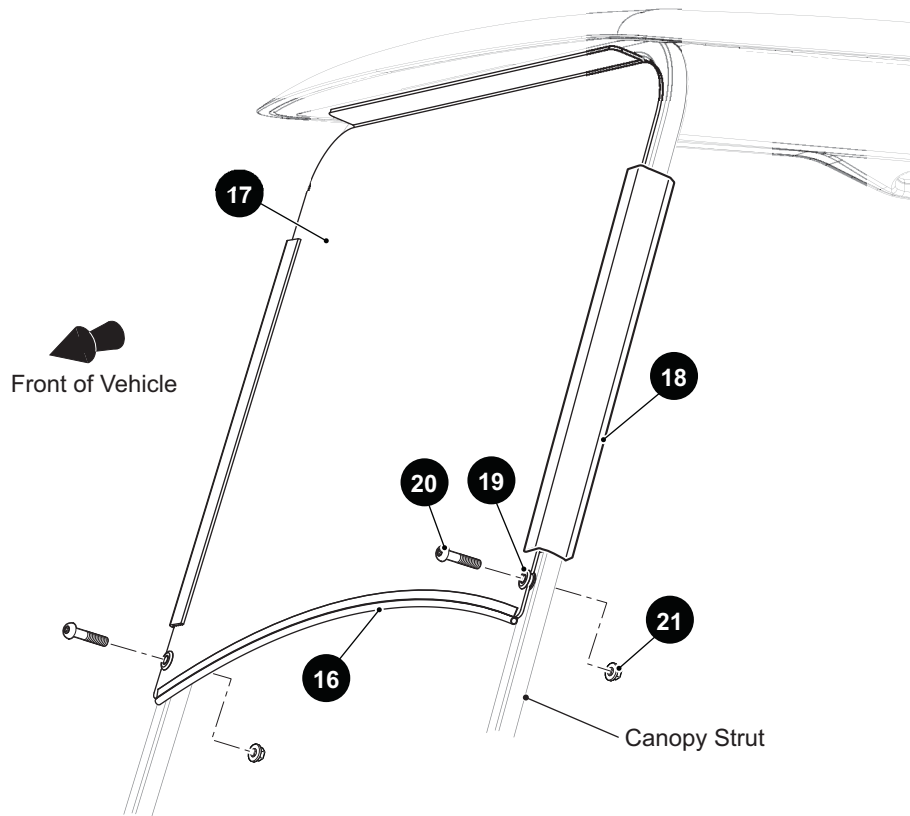

Figure 2 Flat Windshield

WEATHER PROTECTION

Read all of SAFETY and this section before attempting any procedure. Pay particular attention to Notices, Cautions, Warnings and Dangers.

SPLIT WINDSHIELD

Tool List	Quantity
Rubber Mallet	1
Torx Plus Bit, 45 IP	1
Ratchet	1
Socket, 15mm.....	1
Torque Wrench, in. lbs.	1

1. Attach the bulb seal (22) to the bottom edge of the windshield assembly (23).
2. Carefully tap each windshield sash (24) onto the lower half of the windshield assembly (23). Pay careful attention to the orientation of each sash.
3. Install the windshield fastener grommets (25) to the windshield assembly (23).

4. Orient the windshield assembly (23). Align each windshield fastener grommet (25) with the mounting hole in each strut, and clip the sashes (24) to the canopy struts. Clip the upper windshield latches (26) to the canopy struts.
5. Insert torx bolts (27) through each windshield fastener grommet (25) and strut leg, secure with lock nuts (28).
6. The upper portion of the windshield can be folded down by unhooking the upper windshield latches (26) from the canopy strut.
7. Tighten the hardware to the torque values specified below.

Item	Torque Specification
27	70 - 97 in. lbs. (7.9 - 10.9 Nm)

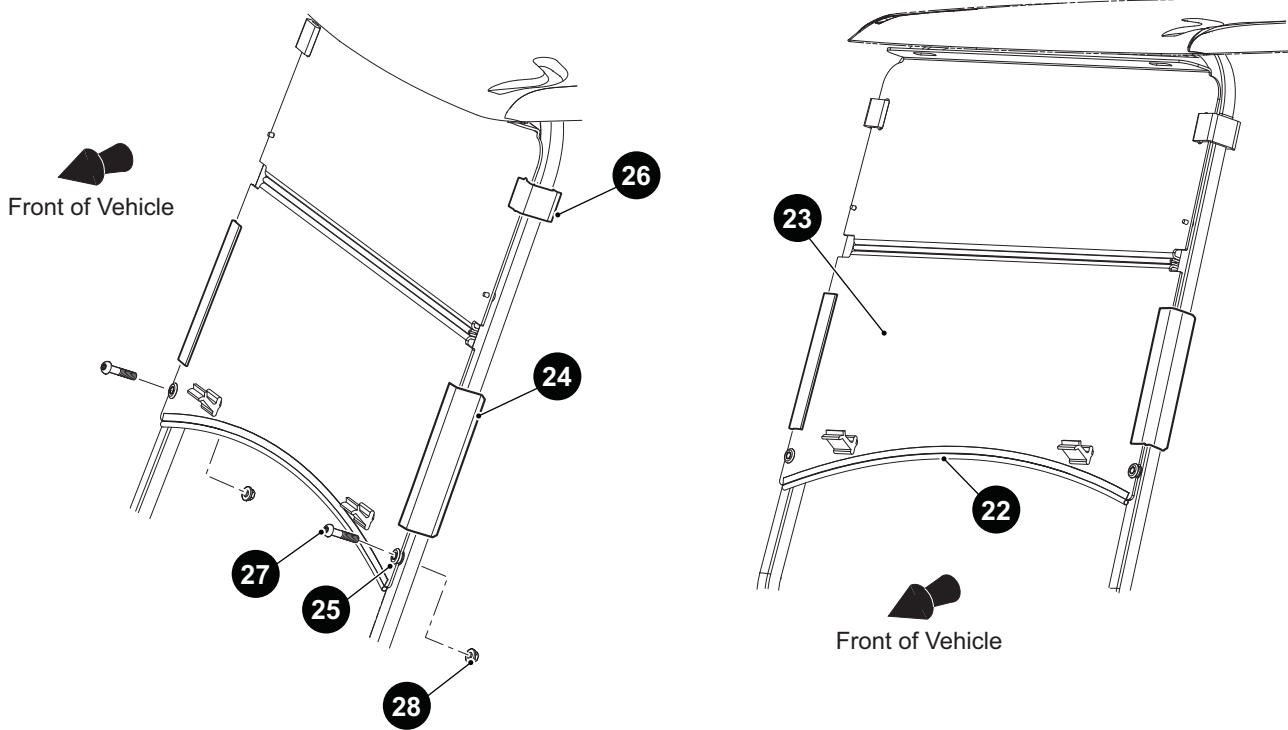

Figure 3 Split Windshield

WHEELS AND TIRES

WHEEL AND TIRE SERVICE

Tool List	Quantity
Lug Wrench, 3/4"	1
Impact Wrench	1
Impact Socket, 3/4"	1
Torque Wrench, ft. lbs.	1

⚠ WARNING

To decrease the risk of tire explosion, add small amounts of air to the tire at intervals to seat the tire beads. Over inflation of small

tires can occur in a few seconds.

Do not over inflate the tires. Excess pressure can cause the tire to separate from the wheel or explode.

Protect face and eyes when removing a tire valve core.

Use only sockets made for use with impact wrenches to decrease the risk of injury caused by a broken socket.

Do not use tires that have a recommended tire inflation pressure less than the tire pressure recommended in the vehicle owner's guide.

Recommended Tire Pressure

Use caution when you inflate the tires. Because of the low volume of the small tires, over inflation can occur in seconds. Over inflation can cause the tire to separate from the wheel or cause a tire explosion.

The general recommended tire inflation pressure is 18-22 psi (124 - 152 kPa). Tire inflation pressure can be adjusted for the condition of the terrain.

For outdoor applications with primary use on areas with grass, consider the following:

- Slightly higher tire inflation pressure is suitable on hard surfaces.
- A lower pressure decreases the risk of tires cutting into turf.

For hard surfaces or pavement, tire inflation pressure must be in the higher allowed range, but not more than recommended on the tire sidewall.

All four tires must have the same pressure for best control qualities. Always install the valve stem cap after you check or inflate the tires.

Tire Pressure Range	Terrain Conditions	Recommendation
18 - 22 psi (124-152 kPa)	Hard surfaces or pavement	Inflate to higher pressure within the range; never exceed maximum pressure indicated
	Soft terrain or turf	Inflate to lower pressure within the range to reduce potential damage to the terrain or turf

Tire Repair

The vehicle is equipped with low-pressure tubeless tires mounted on one piece rims.

The most cost effective way to repair a flat tire with a puncture in the tread portion of the tire is to use a commercial tire plug. For large holes and cuts, replace the tire.

NOTICE: Tire plug tools and plugs are available in automotive outlets. The tire does not have to be removed from the wheel to install a tire plug.

If the tire is flat, lift the vehicle and remove the wheel. Refer to the SAFETY section for the lifting procedure and safety information. Inflate the tire to maximum recommended pressure. Submerge the tire in water to find the leak, and mark with chalk. Insert the tire plug in accordance with manufacturers specifications.

If the tire is being removed or mounted, the tire-changing machine manufacturers recommendations must be followed to minimize the possibility of personal injury. Be sure to place tire on wheel correctly. The arrow on the tire indicates direction of rotation when moving forward.

⚠ WARNING

To decrease the risk of injury, make sure the mounting/demounting machine is anchored to the floor. Wear OSHA approved

safety equipment when mounting/demounting tires.

Follow all instructions and safety warnings provided by the mounting/demounting machine manufacturer.

WHEELS AND TIRES

Read all of SAFETY and this section before attempting any procedure. Pay particular attention to Notices, Cautions, Warnings and Dangers.

Wheel Installation

⚠ CAUTION

To decrease the risk of component damage, do not tighten lug nuts to more than 85 ft. lbs. (115 Nm) torque.

NOTICE: Always follow the cross-sequence pattern when you install the lug nuts to make sure the wheel is evenly seated against the hub.

With the valve stem to the outside of wheel, install the wheel onto the hub with lug nuts.

Finger tighten lug nuts (1) in the cross-sequence pattern as shown (Figure 1). Continue to tighten the lug nuts in 20 ft. lbs. (27 Nm) increments in the cross-sequence pattern until the correct torque value shown below is reached.

Item	Torque Specification
1	65 - 85 ft.lbs. (88 - 115 Nm)

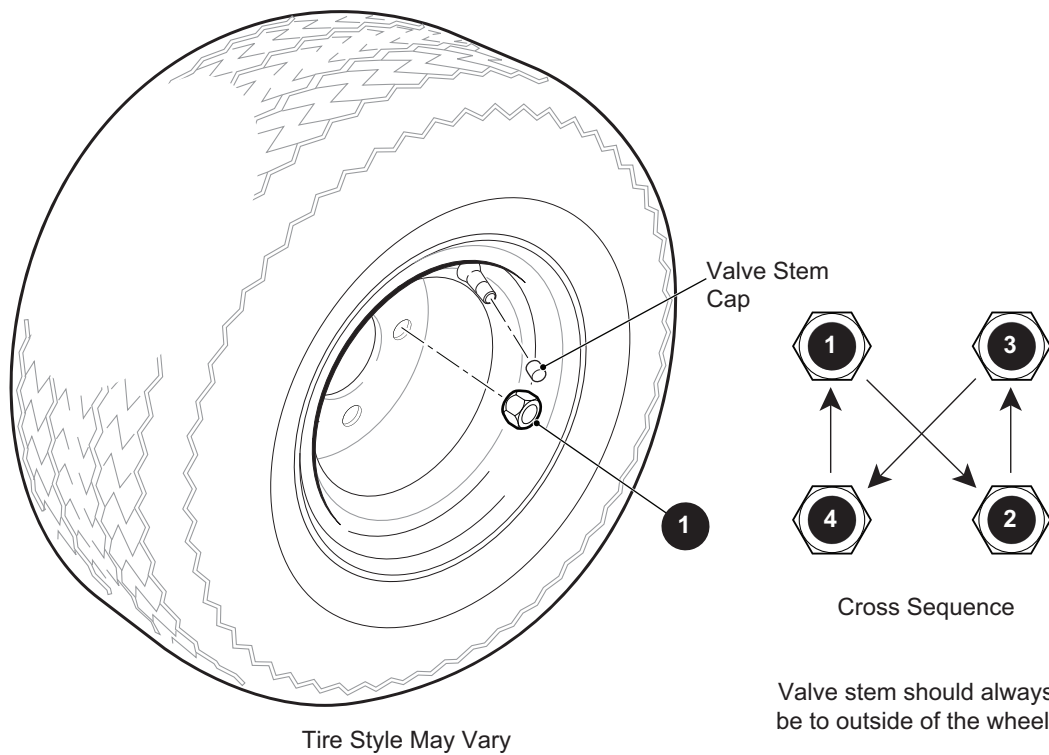

Figure 1 Wheels and Tires

BRAKES

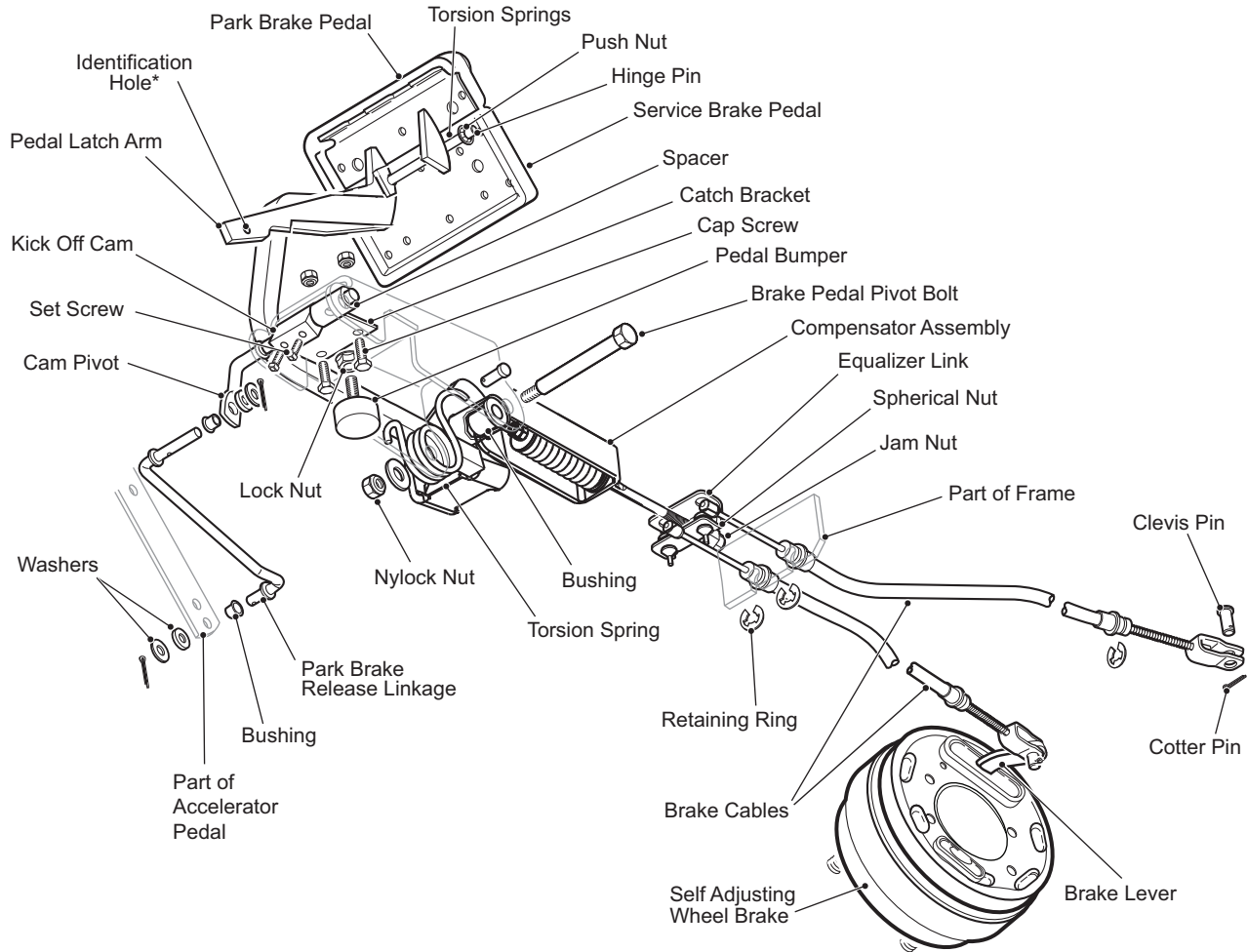

Figure 1 Mechanical Brake System

BRAKE SYSTEM OVERVIEW

General Description

This vehicle is equipped with a mechanically activated rear drum brake system. The brake system consists of a brake and parking brake pedal, parking brake release linkage, compensator assembly, equalizer link, brake cables and self adjusting wheel brake assemblies (Figure 1).

Mechanical brakes depend on the travel of the brake cables to move the brake shoes against the brake drums. The travel of the brake cables is controlled by the brake pedal. If the cables cannot travel far enough to absorb the slack (free travel) in the system and still apply the shoes to the drums, the braking effort at the wheel brake will not be adequate. The self adjusting mechanism in the wheel brakes requires enough cable travel at the wheel brake to work reliably. When the brake is released, there must be

slack in the system so the brakes will release fully and the adjusters will function. Free pedal travel, pedal force, shoe to drum clearance and braking capability are closely related. It is very important to maintain the proper relationships to assure braking performance and the best wheel brake adjustment.

How the Brake Works

Pressing the brake pedal pulls the compensator assembly and equalizer link, which are connected to the brake cables (Figure 1). The first part of the pedal travel removes slack from the system. Continued motion of the brake pedal pulls both the left and right brake cables. Each brake cable pulls a brake lever which pushes the rear brake shoe against the brake drum. When the rear shoe contacts the brake drum, it can no longer move rearward. Additional pedal (and cable) travel causes the actuator bracket (moving anchor) to move and applies force to

BRAKES

Read all of SAFETY and this section before attempting any procedure. Pay particular attention to Notices, Cautions, Warnings and Dangers.

the front shoe, pushing it against the brake drum. The force applied to the front and rear shoes is approximately equal. As the shoes contact the moving brake drum, the shoes try to move in the direction of drum rotation. This movement results in the typical brake shoe wear patterns.

Equalizer Link

The equalizer link balances braking between the driver and passenger sides of the vehicle. Variations in wheel brake adjustment, cable friction and manufacturing tolerances may cause the equalizer to be slightly misaligned. This misalignment is normal.

Automatic Adjuster Mechanism

CAUTION Never manually adjust the brakes at the star wheel. Doing so will cause permanent damage to the adjuster assembly and result in a gradual loss of brakes.

The wheel brakes are equipped with an automatic adjuster mechanism that is designed to compensate for brake shoe wear and eliminate the need for manual brake shoe adjustment. The brake adjuster is activated by movement of the lever attached to the brake cable.

How the Parking Brake Works

The parking brake is operated by a smaller pedal which extends across the top of the brake pedal. It is spring loaded and attached to the brake pedal with a hinge pin (Figure 2).

Pressing the parking brake pedal moves the latch arm against the catch bracket attached to the chassis. As the parking brake is pressed, the brake is applied until the notch in the latch arm engages with the catch bracket. The brake pedal is held in the applied (down) position by the catch bracket.

The latch arm is held in position by tension in the brake linkage. The parking brake can be released by two methods:

1. Pressing the brake, which permits the spring loaded parking brake pedal to return to its original position, disengages the latch arm from the catch bracket. This is the preferred method because it minimizes wear on components.
2. Pressing the accelerator pedal rotates the kick-off cam and forces the pedal latch arm to move away from the catch bracket. The spring loaded parking brake pedal returns to its original position, releasing brake.

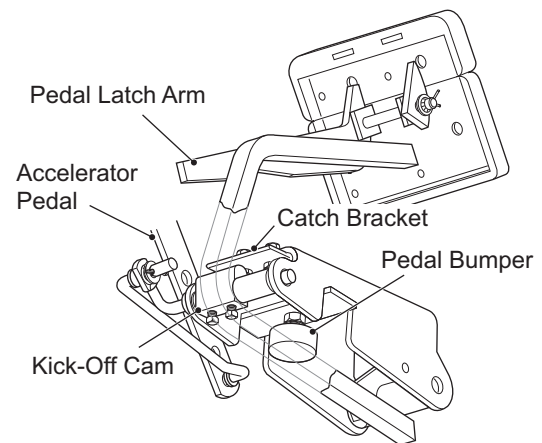
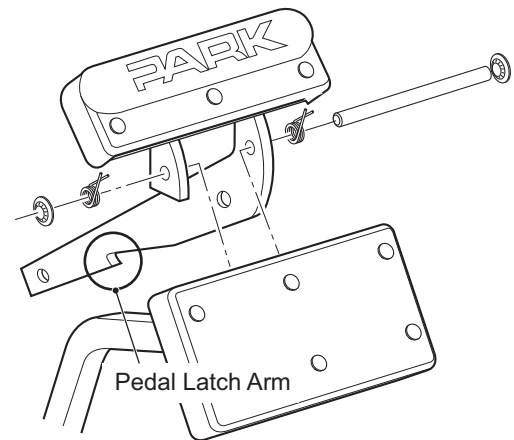

Figure 2 Parking Brake and Kick-Off Mechanism

Kick-Off Actuating Linkage

The kick-off actuating linkage may require adjustment to compensate for the normal wear. Replacement of any linkage components will also require an adjustment.

Compensator Assembly

The compensator assembly contains a spring, which is compressed until the stop tube within the spring is engaged and the linkage becomes solid (Figure 3). The brake compensator assembly applies a spring load to the parking brake system and ensures that the parking brake remains under tension when it is engaged.

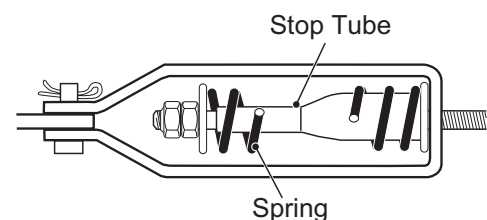

Figure 3 Compensator Assembly

Read all of SAFETY and this section before attempting any procedure. Pay particular attention to Notices, Cautions, Warnings and Dangers.

FAULT TESTING FLOWCHART

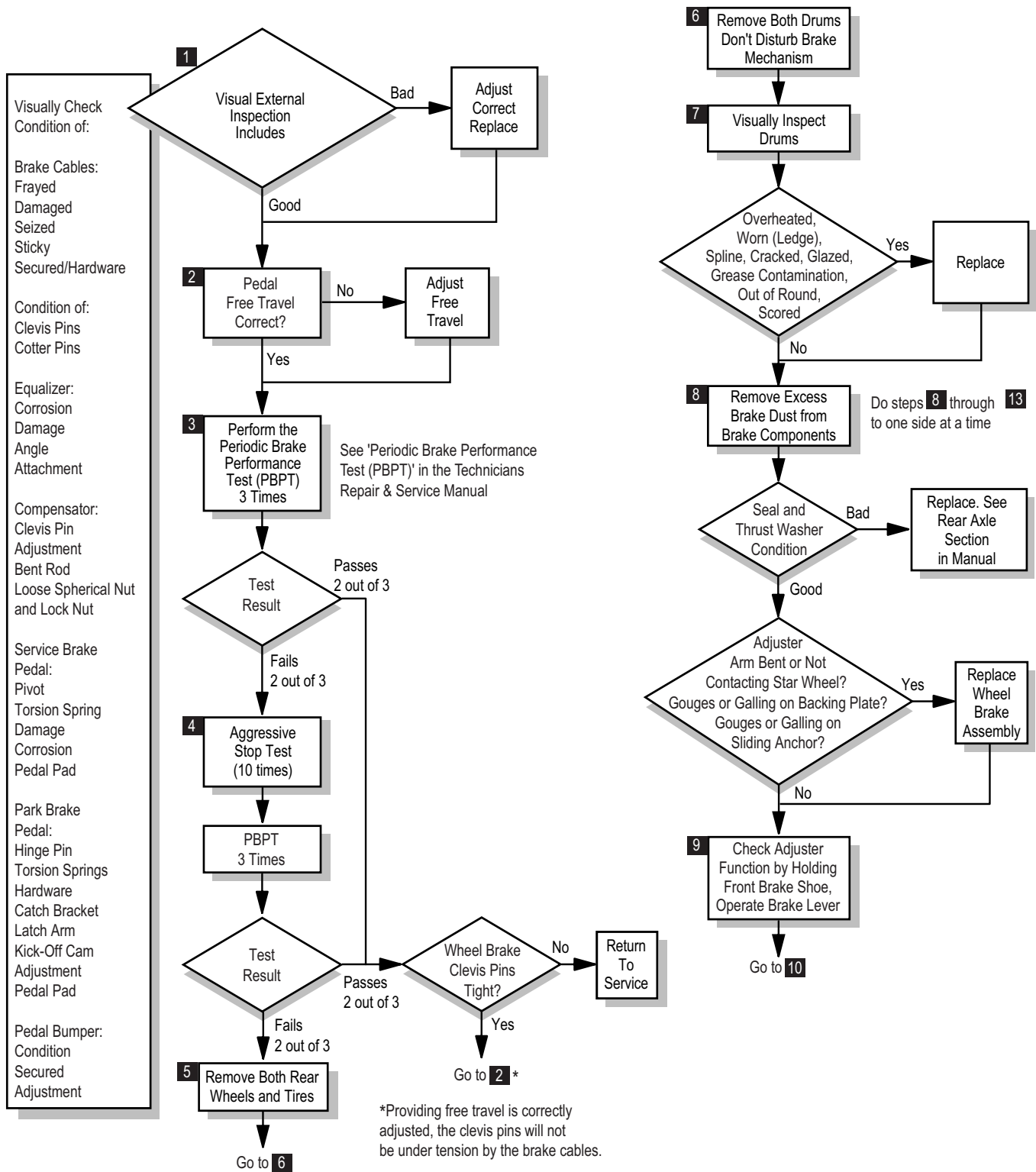

Figure 4 Fault Testing Flowchart

BRAKES

Read all of SAFETY and this section before attempting any procedure. Pay particular attention to Notices, Cautions, Warnings and Dangers.

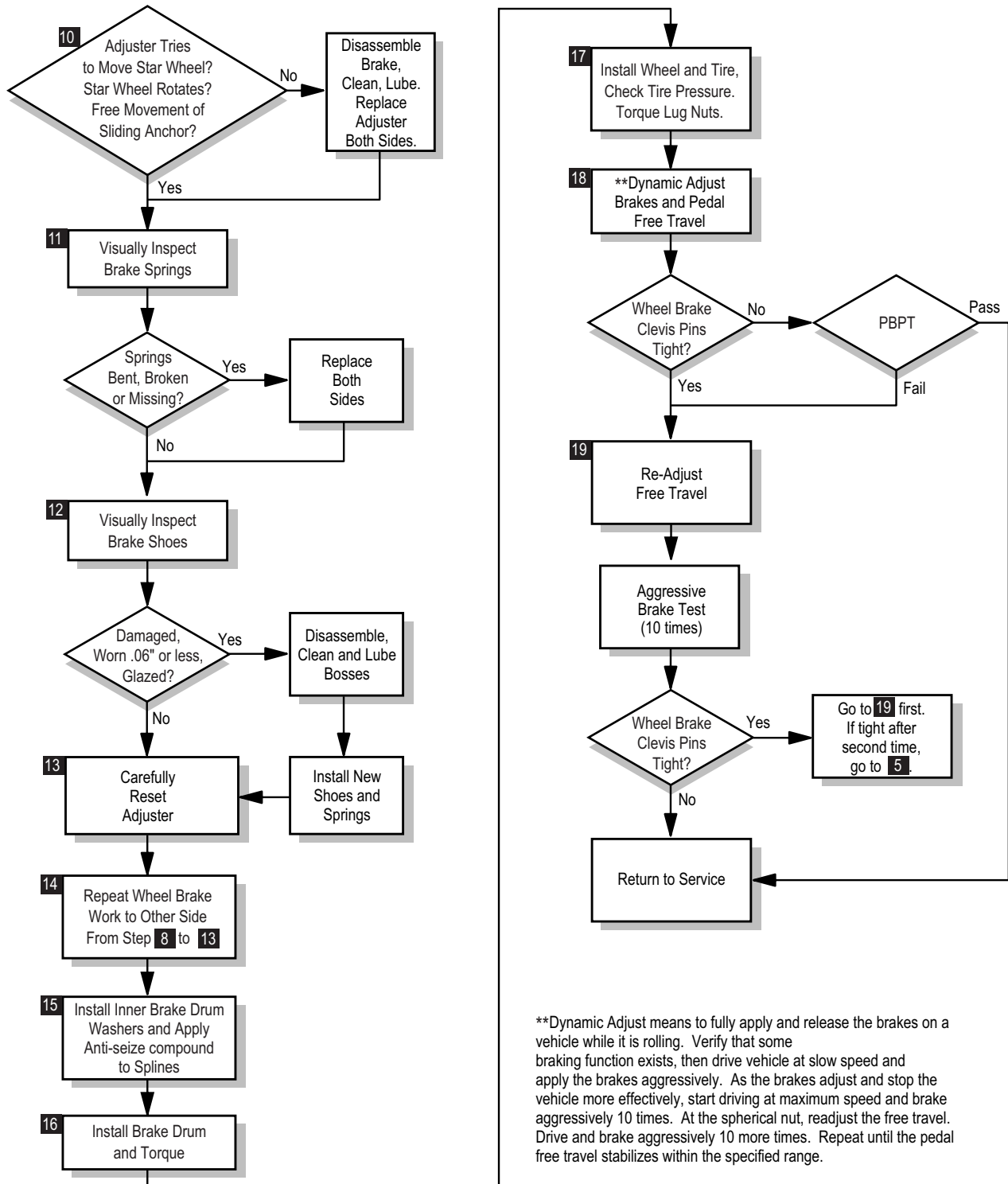

Figure 5 Fault Testing Flowchart

BRAKES

Read all of SAFETY and this section before attempting any procedure. Pay particular attention to Notices, Cautions, Warnings and Dangers.

FAULT TESTING TABLE

thorough visual inspection, Daily Brake Performance Test has been performed (Figure 6).

Refer to the following fault diagnosis table only after the

Condition	Possible Cause	Correction
Fails Brake Performance Test by stopping in a longer distance than normal	Wheel brake failure due to severely worn or damaged components	Replace all severely worn or damaged components
	Brake pedal not returning	Check for binding of brake pedal
	Brake not adjusting	Check brake pedal free travel Check brake cables Check brake adjusters Check pedal pivot
	Brake shoes wet	Check again when shoes are dry
	Brake cables damaged or sticky	Check brake cable and replace if sticky or damaged
	Brake shoes severely worn	Replace
	Brake shoes glazed	Sand shoes with emery cloth provided that shoes have .06" (1.5 mm) min. material
	System not adjusted properly	Check and adjust per manual
	End of brake cable loose from anchor brackets Cracked brake drum	Check and repair Replace
In excess of 1-1/8" (2.9 cm) free pedal travel (Soft Pedal)	Low pedal force at parking brake latch	Adjust per manual
	Brake cables damaged	Replace
	Brake return bumper out of adjustment	Adjust per manual
	End of brake cable loose from anchor brackets	Check and repair
	Wheel brake failure due to severely worn or damaged components System not adjusted properly	Replace all severely worn or damaged components Adjust per manual
Less than 7/8" (2.2 cm) free pedal travel (Hard Pedal)	High pedal force at parking brake latch	Adjust per manual
	Brake cables damaged or sticky	Check brake cable and replace if sticky or damaged
	System not adjusted properly	Check and adjust per manual
	Wheel brake failure due to severely worn or damaged components	Replace all severely worn or damaged components
Neither wheel locks when parking brake is latched. (Note: At full speed the wheels may not lock, but should brake aggressively).	Incorrect compensator spring adjustment	Return to factory specification
	Excessive brake pedal free travel	Adjust per manual
Unequal braking (one wheel locks while other rotates)	Wheel not locking is not adjusting	Check brake operation of wheel that is not locking
	Sticky/dragging cable	Check for brake lever return Check that brake levers return at equal rate - (Indication of dragging cable)
	Cracked brake drum	Replace
	Brake shoes wet or glazed	Check again when shoes are dry
	Rusted or sticky brake pivot hardware	Replace
Neither wheel locks	Brake system requires complete adjustment	Adjust entire system
	Brake pedal not returning	Check for binding of brake pedal Check brake pedal free travel

Figure 6 Fault Testing Table

BRAKES

Read all of SAFETY and this section before attempting any procedure. Pay particular attention to Notices, Cautions, Warnings and Dangers.

Condition	Possible Cause	Correction
Grabbing brakes (oversensitive)	Moisture has caused surface rust on drums	Apply moderate force to pedal while at maximum level ground speed to remove rust until condition is relieved.
	Brake Pivot binding	Check and replace poor components
parking brake hard to latch	Inadequate free play	Adjust pedal free travel at spherical nut and check that wheel brake actuators are returning fully
	Sticky/dragging cable	Check for brake lever return Check that brake levers return at equal rate - (Indication of dragging cable)
	Dragging shoes	Check wheel brakes
parking brake will not stay latched	Excessive wear	Check for worn latch mechanism

Figure 6 Fault Testing Table (Continued)

FAULT DIAGNOSIS AND INSPECTION

New Vehicle

A new vehicle will experience an initial break-in of components including the brake cables and brake shoes. In this break-in period, it is common for the brake pedal free travel (and the effort required to latch the parking brake) to change. The timing of this change varies with terrain and the driving habits of the operator(s). When this occurs, the brake linkage must be adjusted. See *Adjusting Brake Pedal Free Travel*. After the initial break-in period, no further adjustments are necessary until routine maintenance is scheduled.

Fault Diagnosis and Inspection Procedures

To find the problem in the mechanical brake system, inspect the brake pedal and linkage to find worn or damaged parts per the Fault Diagnosis Table. Then, do the Periodic Brake Performance Test to evaluate the brake system performance. Based on the results of the inspection and tests, refer to the Fault Diagnosis Table (Figure 6) to evaluate symptoms and repairs. If necessary, disassemble the wheel brake to find and correct internal faults.

For removal or replacement of parts and adjustments referred to in this section of the manual are described in detail under See the *MAINTENANCE AND REPAIRS*.

CAUTION *Satisfactory brake performance does not eliminate the need for routine brake testing and inspection as indicated in the SCHEDULED MAINTENANCE sec-*

tion. Correct brake operation depends on maintenance.

Brake Pedal and Linkage Inspection

1. **Inspect brake pedal return bumper.**
Ensure that the pedal is contacting the return bumper when released, that the bumper is in good condition and that a 1/4" - 3/8" (6 - 9.5 mm) gap exists between the pedal arm and the setscrew heads of the kick-off cam (Figure 7). Replace or adjust the bumper if required. See the *Pedal Bumper Adjustment*.

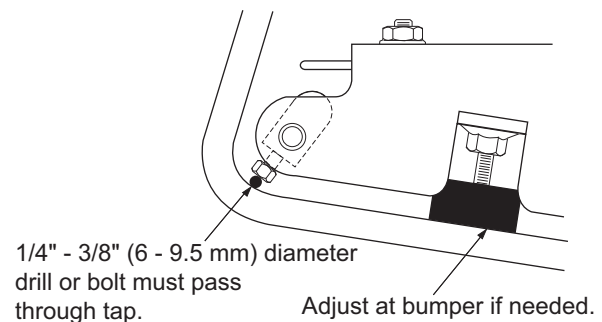

Figure 7 Brake Pedal Bumper Inspection

2. **Check brake pedal return.**
Apply the brake pedal and release. Check that the brake pedal arm rests against the return bumper when released. Check that the torsion spring is hooked around both the pedal and the frame and is in good condition. If the pedal does not return fully or is sluggish, the brake pedal bushings and pivot bolt should be inspected (Figure 8). Replace pedal, spring, bushings and bolt as required. See the *Brake Pedal Removal and Installation*.

BRAKES

Read all of SAFETY and this section before attempting any procedure. Pay particular attention to Notices, Cautions, Warnings and Dangers.

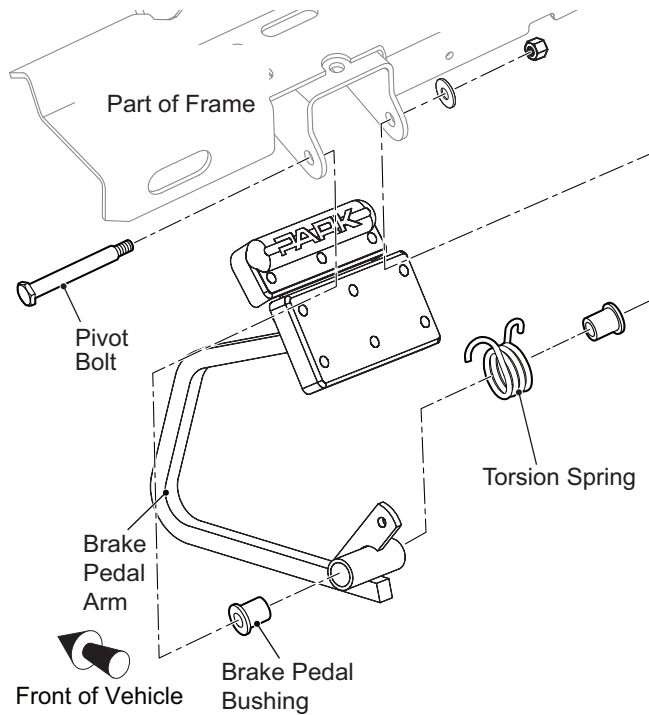

Figure 8 Brake Pedal Inspection

3. **Check the brake pedal free travel.**

Brake pedal free travel refers to the distance the pedal moves from rest, to the point at which the brake shoes first contact the brake drums. This should not be confused with the light resistance that is felt as the brake pedal is pressed enough to remove slack from the compensator and cables. Too much free travel may indicate wheel brakes not adjusting, wear in the cables and linkages or initial break-in of components. Not enough free travel can indicate improper adjustment of the wheel brake or the brake linkage. Either condition can prevent the brakes from adjusting properly.

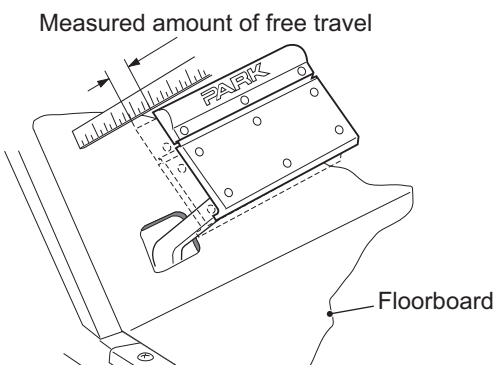

Figure 9 Check Free Travel

The correct brake pedal free travel should be set to 7/8" - 1-1/8" (2.2 - 2.9 cm) (Figure 9).

The parking brake lock force can be checked for verification after setting brake pedal free travel. The recommended method of checking parking brake lock force is to place a 'bathroom' scale on the brake pedal. Use both feet, press the scale down equally against the parking brake pedal until it latches. The parking brake must lock between 65 and 75 lbs. (29 - 34 kg) indicated on the scale (Figure 10). If necessary, adjust the spherical nut to achieve correct latching pressure.

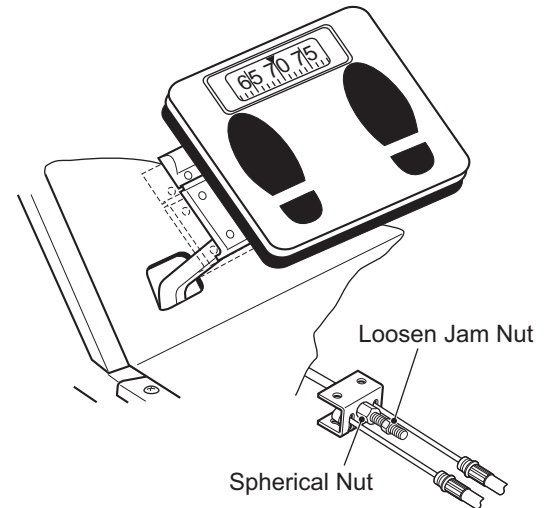

Figure 10 Checking Parking Brake Latching Pressure

Adjust the brake pedal free travel as described See the *MAINTENANCE AND REPAIRS*. if required.

4. **Inspect the brake cables.**

Inspect for damage to the outer cable, wear of the inner cable or no free motion when the pedal is applied and released. Inspect the brake cable supports to make sure the cables are correctly secured. If any of these conditions are found, replace both cables and equalizer.

5. **Check the clevis pins.**

Check the clevis pins that secure the brake cables to the brake lever. When the brake pedal is released (Figure 11), the clevis pins must be not loose. If the clevis pin is not loose, but brake pedal free travel is correctly adjusted and the brake cables move freely, the problem may be in the wheel brake.

BRAKES

Read all of SAFETY and this section before attempting any procedure. Pay particular attention to Notices, Cautions, Warnings and Dangers.

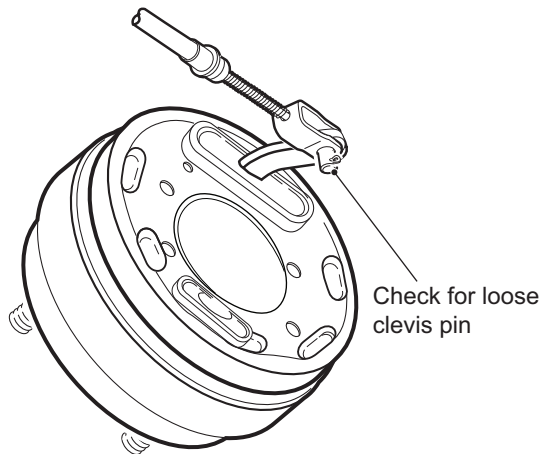
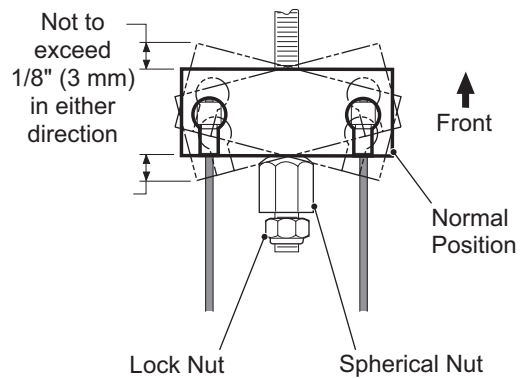

Figure 11 Check Clevis Pins



View From Below

NOTE: This dimension is factory pre-set with the parking brake disengaged and should not be changed.

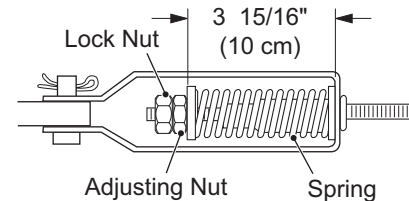

Figure 12 Equalizer and Compensator

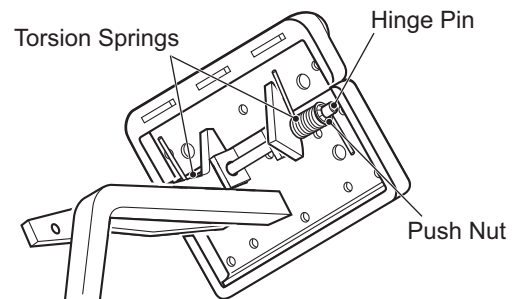

Figure 13 Parking Brake Pedal Hinge Inspection

6. **Inspect the brake cable equalizer linkage.** Inspect for corrosion, damage, wear or excessive misalignment (Figure 12). Replace the cable if corrosion, damage, or wear is found.
7. **Inspect the compensator assembly.** Inspect for damage, corrosion or wear; replace complete assembly if present. In general, adjustment will not be necessary, as the spring assembly is factory calibrated. With the parking brake disengaged, check that the compensator spring length is 3-15/16" (10 cm) (Figure 12). If an adjustment is required, it must be made using the nuts towards the front of the vehicle. Tighten the lock nut after your are finished adjusting the compensator assembly.
8. **Inspect parking brake pedal hinge.** Check for broken springs, and correct retention of the hinge pin. Operate the parking brake pedal to confirm smooth operation of the hinge mechanism (Figure 13).

9. **Check the condition and operation of the parking brake latching mechanism.** The parking brake should latch firmly and release as soon as the accelerator pedal is pressed.

WARNING To prevent serious injury or death from the use of worn parking brake components, do not attempt to re-new worn parts. The parking brake latch arm, kick-off cam and catch bracket are hardened parts. Do not grind or file them, as doing so will cause the

Read all of SAFETY and this section before attempting any procedure. Pay particular attention to Notices, Cautions, Warnings and Dangers.

parts to lose their hardness properties. Always use new parts.

10. **Inspect catch bracket and latch arm.**
Replace if indication of wear or damage are found (Figure 14).
11. **Inspect the parking brake kick-off cam.**
Look for wear and ensure correct adjustment. With the parking brake engaged and fully latched, there must be no gap between the top of the cam and the latch arm. Adjust the kick-off cam (3) if required (Figure 14). Correct setscrews must be used to hold the kick-off cam to the pivot rod. Use of longer screws prevent correct adjustment of pedal bumper (pedal travel) and may prevent the brakes from adjusting properly.
12. **Inspect kick-off cam linkage and bushings.**
Check for wear and damage. The kick-off cam pivot and bushings must move freely and be free of corrosion. The kick-off cam should rotate when the accelerator pedal is pressed.

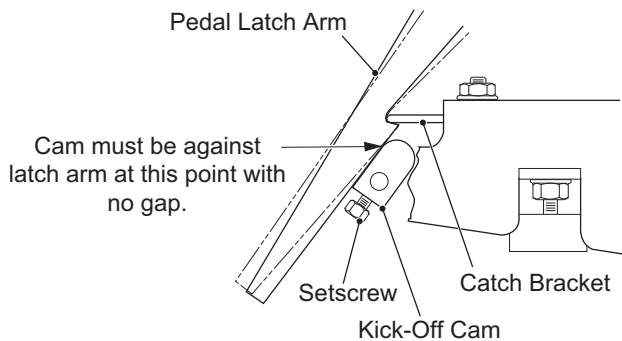

Figure 14 Kick-Off Cam Inspection

Daily Brake Performance Test

NOTICE: To ensure correct braking performance, all maintenance, inspections and procedures must be performed as indicated in the SCHEDULED MAINTENANCE section. A Daily Brake Performance Test must be performed, and the entire brake system must be serviced in accordance with the Scheduled Maintenance.

NOTICE: The brake system must be bled whenever any part of the brake system has been replaced.

Press the brake pedal. The pedal should have some initial free play, and then become resistant. This indicates proper performance.

If the brake pedal has a soft feel or loses resistance, perform a brake system inspection, See *Brake System Inspection*.

Brake System Inspection

Brake failure usually occurs as either a gradual decrease in braking effect from the disc pads wearing away, a loss of braking at one wheel or a sudden and complete failure with no brakes working except the parking brake. If the brakes at one wheel become ineffective while the brakes at the other wheel functions properly, remove the entire brake assembly and inspect the brake for signs of a leaking or inoperative wheel cylinder assembly.

Wheel Brake Inspection

WARNING Wear a dust mask and eye protection when working on wheel brakes.

Do not use pressurized air to blow dust from the brake assemblies.

Replace both brake shoes on both wheels if one or more shoes are worn below .06" (1.5 mm) thickness at any point.

CAUTION Do NOT touch any of the wheel brake mechanisms except as instructed.

Do NOT use a commercial brake cleaner unless the entire brake has been disassembled.

1. Remove the brake drums.
Do not disturb adjuster mechanisms. Remove excess dust and dirt from the drum with a brush.

WARNING The drum must not be machined to remove grooves in the friction surface. Machining the drum makes the wall thin and can cause the drum to fail. Drum failure causes a loss of braking capacity, which can cause severe injury or death.

2. Inspect the brake drum.
Look for a blue coloration or blistered paint indicates that the drum has overheated. Check for grooves in the friction surface. Check for an area worn below the rest of the friction surface indicating excessive wear. Inspect the splines for galling, wear and corrosion. If any of these problems are present, the drum must be replaced.
3. Remove any accumulated brake dust from the wheel brake assembly with a brush.
4. Visually inspect the axle seal for oil leakage, and the condition of the thrust washer. If oil is present, see REAR AXLE section.
5. Verify the inner brake drum washer is present and check its condition. Replace if damaged or missing.

BRAKES

Read all of SAFETY and this section before attempting any procedure. Pay particular attention to Notices, Cautions, Warnings and Dangers.

WARNING If one wheel brake assembly is replaced, the one on the other side must also be replaced.

CAUTION Be careful when you handle the adjuster arm. Excessive force will damage the adjuster and both wheel brake assemblies will need to be replaced.

6. Visually check the condition and operation of the adjuster mechanism.
 - Inspect the brake lever for damage or wear. Test the adjuster function as follows:
 - Push the front brake shoe in the direction of the rear of the vehicle and hold in position.
 - Operate the brake lever.
 - Observe the brake adjuster arm and note if the arm engages the star wheel and tries to rotate it (Figure 15).

If the adjuster arm **engages and turns** the star wheel, proceed. If the arm **fails to engage** the star wheel, it has been damaged and both wheel brake assemblies must be replaced.

If the adjuster arm engages the star wheel but **fails to rotate it**, the adjuster assemblies must be replaced with new color-coded adjusters. Note the location of the two Teflon coated washers (Figure 15).

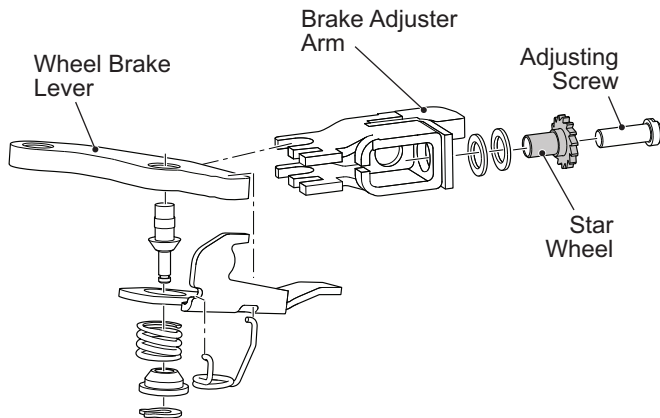

Figure 15 Adjuster Mechanism

7. Check the condition and operation of the moving anchor assembly (Figure 15). Operate the brake lever to check for free motion. The adjuster assembly and brake lever should move smoothly from front to back on the backing plate. If the moving anchor assembly is damaged or jams against the backing plate, replace both wheel brake assemblies.

WARNING A backing plate assembly that shows any indication of galling or gouging is not repairable and must

be replaced with a new wheel brake assembly. Always replace wheel brake assemblies in pairs.

8. Inspect the backing plate. Inspect for gouges, galling or other damage, particularly where the backing plate is contacted by the brake shoes and by the moving anchor assembly. Replace both backing plates if any gouges or galling is found.
9. Measure the brake shoe thickness. Measure the most worn area. Brake shoe thickness must never be less than .06" (1.5 mm) at any point on the shoe. It is normal for the shoes to show more wear at the leading and trailing edges (Figure 26). If the brake shoe thickness is approaching .06" (1.5 mm), the shoes should be replaced. The brake shoe springs and brake adjusters should be replaced when installing new brake shoes.
10. Inspect the brake shoe springs. Ensure springs are not broken or damaged and are correctly installed. The springs must be inserted with the light spring at the bottom. The long hook is installed down through the rear brake shoe. The heavier top spring is installed with the spring hooks facing up. The heavy top spring is installed with both spring hooks installed down through the brake shoes (Figure 17).

The pattern of normal brake shoe wear is shown in quadrant A, B, C & D with quadrant A showing the most wear. Quadrant B will show the second most wear.

11. Repeat procedure at the opposite wheel brake.
12. Check/adjust brake pedal free travel. When the brake system is serviced or require parts replaced, the brake pedal free travel must be checked and adjusted. See *Adjusting Brake Pedal Free Travel*. This includes all linkage and wheel brake components.

Read all of SAFETY and this section before attempting any procedure. Pay particular attention to Notices, Cautions, Warnings and Dangers.

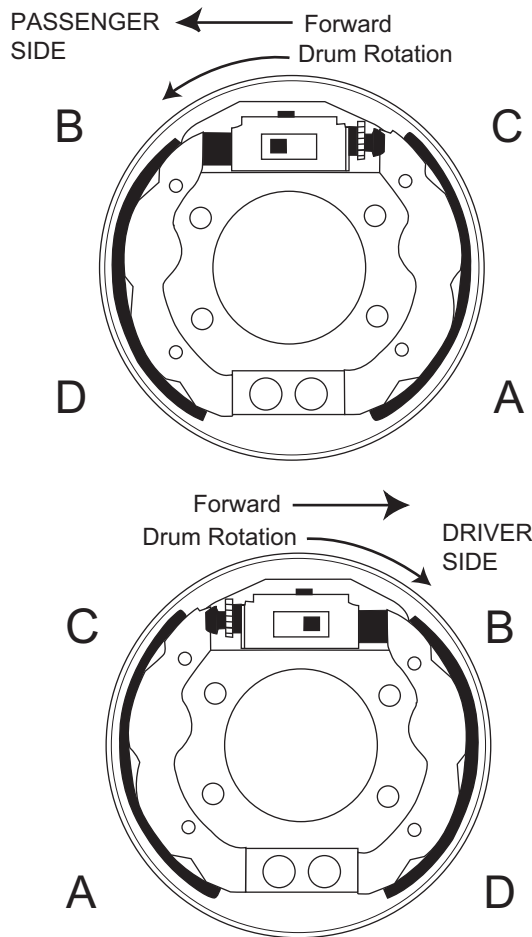

Figure 16 Brake Shoe Wear (Top Pull)

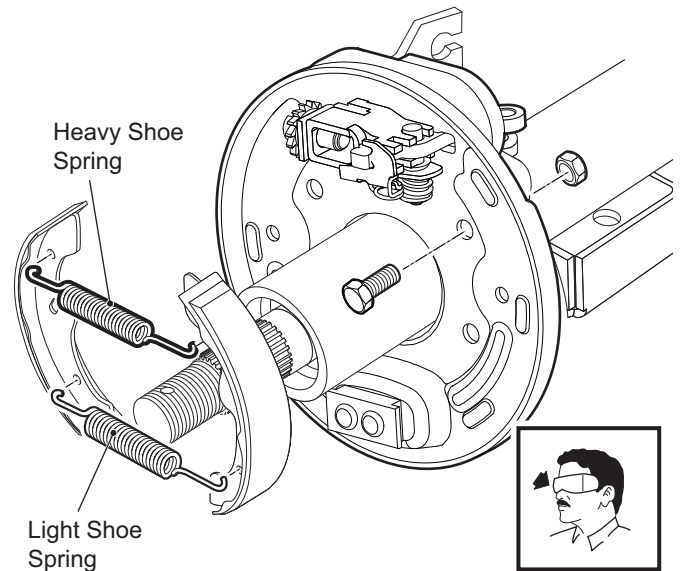

Figure 17 Orientation of Brake Shoe Springs

MAINTENANCE AND REPAIRS

Tool List	Quantity
Hydraulic Floor Jack	1
Scale	1
Jack Stands	4
Wheel Chocks	4
Socket, 1/2"	1
Socket, 3/4"	1
Socket, 11/16"	1
Socket, 15/16"	1
Socket, 1 1/8"	1
Socket, 1/4"	1
Torque Wrench, ft. lbs.	1
Torque Wrench, in. lbs.	1
Extension, 6"	1
Ratchet	1
Open End Wrench, 1/4"	1
Open End Wrench, 1/2"	1
Open End Wrench, 5/8"	1
Straight Blade Screwdriver	1
Straight Blade Screwdriver, Narrow	1
Pliers	1
Vernier/Dial Calipers	1
Plastic Tipped Hammer	1
Puller (P/N 15947G1)	1
Pry Bar	1
Dust Mask	1
Emery Cloth	1

BRAKES

Read all of SAFETY and this section before attempting any procedure. Pay particular attention to Notices, Cautions, Warnings and Dangers.

Adjusting Brake Pedal Free Travel

CAUTION Brake pedal free travel must be checked and adjusted any time the brake system is serviced, or when parts are replaced.

Brake pedal free travel refers to the distance the pedal travels from rest to the point at which the brake cables start to move the brake levers. This should not be confused with the light resistance felt as the brake pedal is pressed enough to remove slack from the compensator and cables. Correct adjustment of free travel is essential to proper brake function. Excess free travel will limit braking capability; insufficient free travel may cause the brakes to drag (not fully release). Either condition can prevent the brakes from adjusting properly.

WARNING The purpose of this procedure is to adjust the brakes and seat brake system components. The brake system cannot be effective for the first few applications of the brake pedal.

Pre-adjust brake pedal free travel to the correct setting by loosening the jam nut and adjusting the spherical nut (Figure 18). Tighten the jam nut to the torque value specified below.

Item	Torque Specification
Jam Nut	10 - 11 ft. lbs. (14 - 15 Nm)

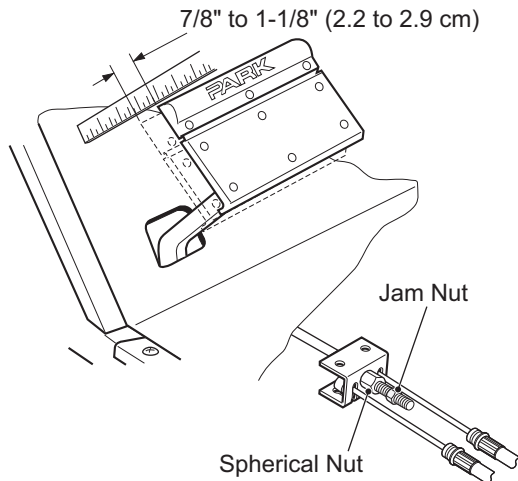

Figure 18 Free Travel Adjustment

The correct brake pedal free travel is 7/8" to 1-1/8" (2.2 to 2.9 cm).

Press the brake pedal aggressively four to six times to establish known free travel.

WARNING All brake tests must be done in a safe location with regard for the safety of all personnel.

In a safe location, free from people and vehicles, drive the vehicle at reduced speed and apply the brakes aggressively. As the brakes begin to adjust and stop the vehicle effectively, start driving at maximum speed and brake aggressively 10 times.

At the spherical nut, adjust the free travel as noted above.

Drive again and brake aggressively 10 times.

Repeat the previous step(s) until the pedal free travel does not change during the aggressive braking.

Check to see that the clevis pins attaching the brake cables to the brake levers are loose (Figure 19). If they are not loose, inspect the system again and correct as required. If the clevis pins are loose, tighten the jam nut at the spherical nut to the torque value specified below.

Item	Torque Specification
Jam Nut	10 - 11 ft. lbs. (14 - 15 Nm)

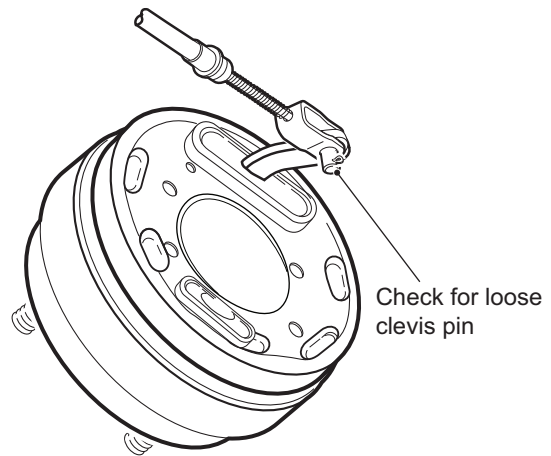

Figure 19 Check Clevis Pins

The parking brake latching force can be checked as verification after setting brake pedal free travel. To check the parking brake latching force, place a bathroom scale on the brake pedal. Use both feet to press the scale down against the parking brake pedal until it latches. The parking brake should latch between 65 and 75 lbs. (29 - 34 kg) indicated on the scale (Figure 20).

Perform the Periodic Brake Performance Test as described and return the vehicle to service if brake performance is satisfactory.

Read all of SAFETY and this section before attempting any procedure. Pay particular attention to Notices, Cautions, Warnings and Dangers.

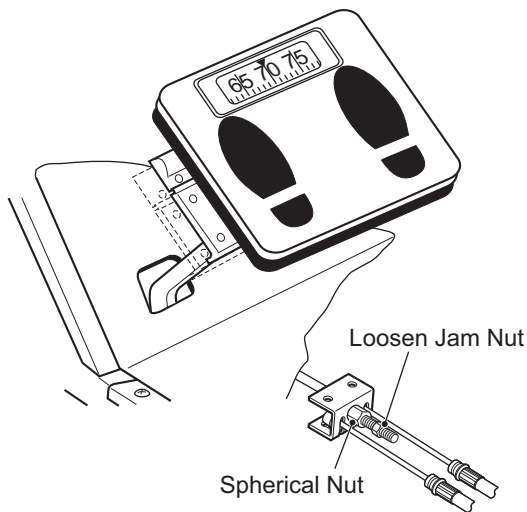

Figure 20 Checking Parking Brake Latching Pressure

Brake Drum Removal and Installation

Remove the dust cap, to gain access to the castellated nut (2) and cotter pin (3) (Figure 21).

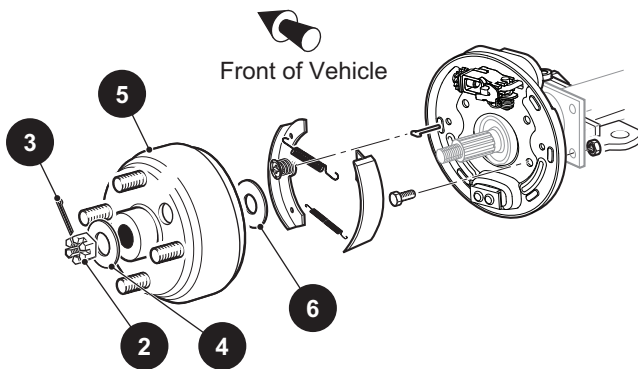

Figure 21 Brake Assembly

Remove the cotter pin (3) and castellated nut.

NOTICE: Do not apply the brake when removing the nut as the shoes may not fully retract, preventing removal of the brake drum.

Remove the washer (4).

Slide the brake drum (5) from the axle shaft. If required, tap the drum with a plastic faced hammer to loosen it from the axle shaft or use drum puller (P/N 15947G1).

CAUTION Be careful when raising the adjuster arm. Excessive force will damage the adjuster and necessitate both wheel brake assemblies be replaced.

If the drum does not slide from the brake assembly, the brake shoes must be retracted. Rotate the hub so that the

hole in the drum is directly over the brake mechanism. Use a small straight blade screwdriver to raise the adjuster arm **just above** the star wheel.

Loosen the star wheel to retract the brake shoes and remove the brake drum.

NOTICE: Pay particular attention to the location of the inner brake drum washer (6) inside the brake drum. It may be on the axle shaft or attached to the rear of the drum hub. This washer must be reinstalled when the brake is reassembled.

To install the brake drum, clean the axle shaft and the splines on the brake drum to remove debris and grease.

Apply a small amount of anti-seize compound to the axle spline.

Install the inner brake drum washer (6) and slide the brake drum (5) into place (Figure 21).

Make sure the nose of the drum hub is beyond the end of the axle splines. If not, remove the drum and install one additional inner brake drum washer (total of two) to obtain required spacing.

CAUTION Do not back off the nut to install the cotter pin.

Install the remaining hardware. Continue to tighten until a new cotter pin can be installed through the castellated nut and the hole in the axle. Maximum torque is 140 ft. lbs. (190 Nm). Install the hardware to the torque value specified below.

Item	Torque Specification
2	80 - 90 ft. lbs. (108 - 122 Nm)

Wheel Brake Service

Wheel brake service consists of disassembly, cleaning, inspection, lubrication and reassembly of the wheel brake. Worn or damaged components must be replaced.

Wheel brake service is required ally as a preventive maintenance measure (see SCHEDULED MAINTENANCE section). The wear rate of brake shoes and required service intervals will vary based on usage, terrain and other conditions.

Remove the brake drum as described in See the *Brake Drum Removal and Installation*.

BRAKES

Read all of SAFETY and this section before attempting any procedure. Pay particular attention to Notices, Cautions, Warnings and Dangers.

WARNING Wear eye protection and a mask when cleaning brake components.

Do not use compressed air to remove brake dust from the brake assembly.

CAUTION Do NOT use a commercial brake cleaner unless the entire brake has been disassembled.

Remove any accumulated brake dust with a brush.

Remove brake shoes. See *Brake Shoe Removal*.

Clean backing plate with a commercial brake cleaner. Allow to dry completely.

CAUTION Friction areas between the backing plate and the brake shoes must be lubricated. Be careful not to allow lubricant to contact braking portion of the brake shoes or friction surface of the brake drum. Use only recommended lubricants.

Lubricate the backing plate friction points of the shoes and surfaces with Multi Purpose Grease (MPG) lubricant (Figure 22).

Install the actuator components, adjuster components and brake shoes. See *Brake Shoe Installation*. If the brake shoes and drum are not to be replaced, sand the friction surfaces lightly with an emery cloth to remove any debris.

CAUTION Be sure the adjusting screw is screwed into the star wheel nut until only 1 - 2 threads are exposed.

If brake shoes are replaced, replace brake springs and adjuster components.

Replace springs one side at a time, using the other side as a reference.

Install brake drum as described in See the *Brake Drum Removal and Installation*.

Repeat on other side of vehicle.

Adjust the brake pedal free travel. See *Adjusting Brake Pedal Free Travel*.

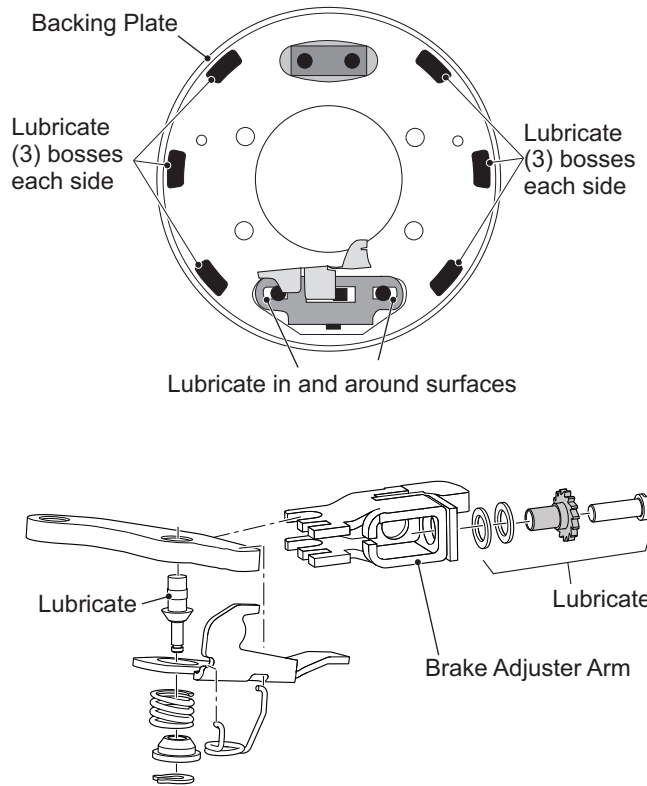

Figure 22 Wheel Brake Lubrication Points

Backing Plate/Entire Wheel Brake Assembly Removal and Installation

Remove four bolts (1) and lock nuts (2) securing the wheel brake backing plate to the flange on the axle tube (Figure 23).

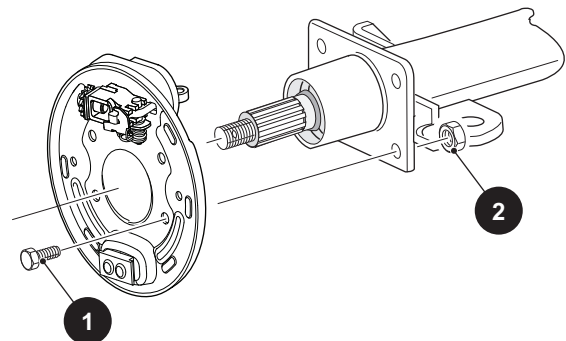

Figure 23 Backing Plate Removal and Installation

Remove the clevis pin securing the brake cable to the brake lever.

Installation is reverse of removal. Connect the brake

Read all of SAFETY and this section before attempting any procedure. Pay particular attention to Notices, Cautions, Warnings and Dangers.

cable to the wheel brake with clevis pin (installed from the top downward) and a new cotter pin.

Install the brake assembly or backing plate to the axle tube flange. Install new hardware (lock nut should not be reused). Tighten the lock nut to the torque value specified below.

Item	Torque Specification
2	23 - 27 ft. lbs. (31 - 36.5 Nm)

Brake Shoe Removal

NOTICE: When brake shoes are replaced, adjusters and springs must also be replaced. Do one side at a time, using the other side for reference.

Use pliers to compress the open end of the brake shoe retainer springs (7) (Figure 24).

While holding the tension pin (2) with a second set of pliers, turn the retainer spring 1/4 turn to align the slot in the spring retainer with the flats in the tension pin. Remove the brake shoe retainer springs.

Grasp the brake shoes (3) in the center and tilt them out and away from the back mounting plate. To release the tension in the brake springs (4). Remove the brake springs and remove the brake shoes.

Inspect the brake shoes. If a brake shoe has less than 0.060 lining material thickness AT ANY POINT on either shoe, both shoes MUST be replaced.

Check for free lateral (front and back) movement of the adjusting mechanism and for free movement of the star wheel.

WARNING Wear a dust mask and eye protection when working on wheel brakes. Do not use pressurized air to blow dust from brake assemblies.

Remove the boot from the brake lever. Clean any accumulated brake dust from backing plate and adjuster mechanism with a brush.

If the brake is being removed for an axle bearing and seal replacement, the four bolts and nuts securing the brake assembly to the rear axle must be removed.

When reinstalling the brake mounting bolts, tighten the bolts to the torque value specified below.

Item	Torque Specification
Bolts	23 - 35 ft. lbs. (31 - 47 Nm)

Clean the backing plate with a commercial brake cleaner. Allow to dry completely.

Lubricate friction points of the shoes and moving anchor with Multi Purpose Grease (MPG) lubricant (Figure 22).

BRAKES

Read all of SAFETY and this section before attempting any procedure. Pay particular attention to Notices, Cautions, Warnings and Dangers.

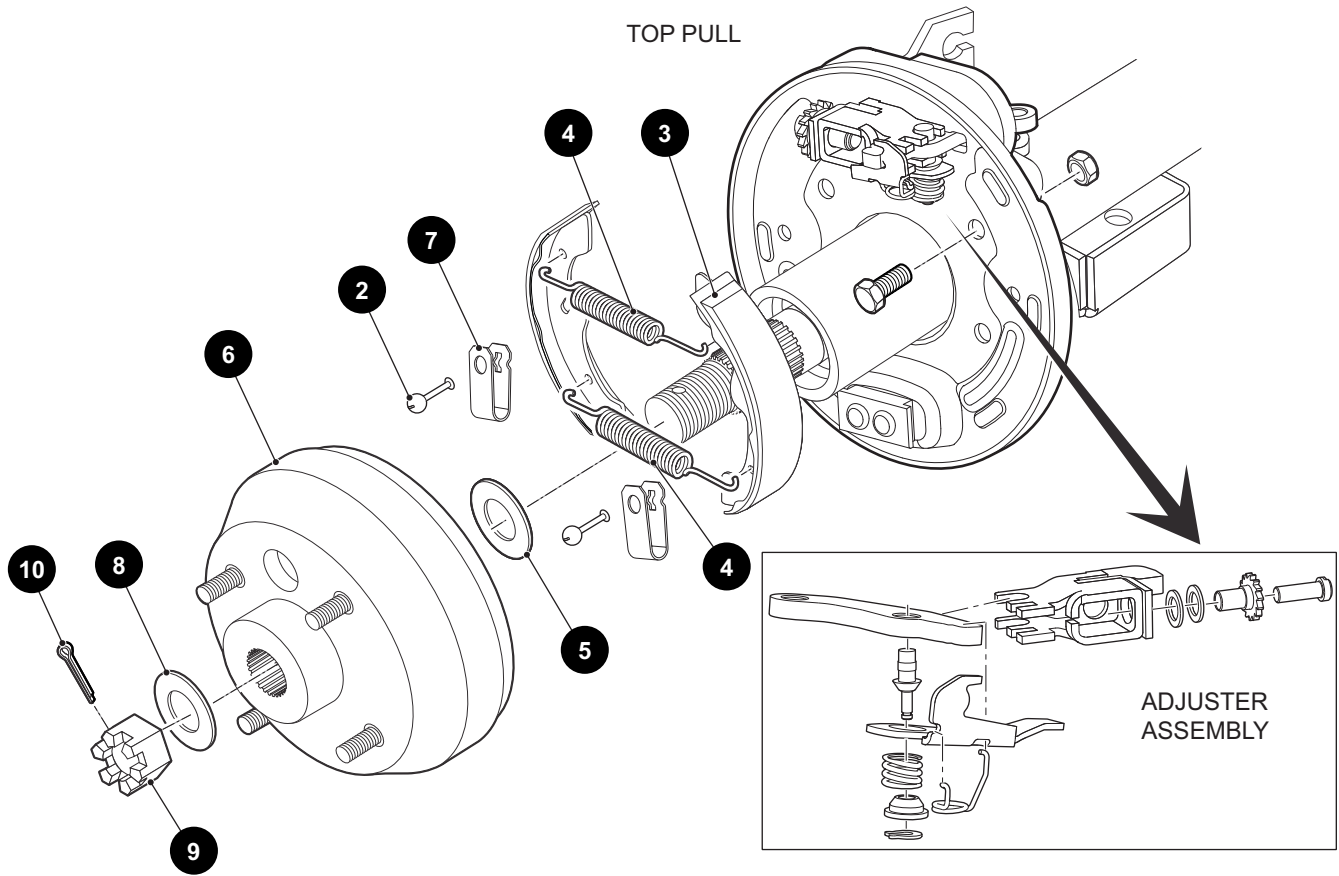

Figure 24 Brake Shoes and Springs

Read all of SAFETY and this section before attempting any procedure. Pay particular attention to Notices, Cautions, Warnings and Dangers.

Brake Shoe Installation

The leading brake shoe (marked 17L) is angled to a narrow end and engages the backside of the adjuster (Figure 25).



Figure 25 Brake Shoe 17L

The trailing brake shoe (marked 17T) is chamfered on wide end and engages the screw end of the adjuster (Figure 26).

Install the brake shoes in reverse order of removal. Secure with brake shoe retainer springs and brake shoe return springs.

Clean the axle shaft to remove debris and grease that may have accumulated.



Figure 26 Brake Shoe 17T

Insert a straight blade screwdriver between the adjusting lever and the adjusting mechanism.

Rotate the star wheel left until the shoes have retracted sufficiently to allow installation of the brake drum.

Install washer (5), brake drum (6), washer (8) and castellated nut (9).

Tighten the castellated nut to the torque value specified below.

Item	Torque Specification
9	80 - 90 ft. lbs. (108 - 122 Nm)

Continue to tighten until a new cotter pin (10) can be installed through the castellated nut and the hole in the axle. Maximum torque 140 ft. lbs. (190 Nm).

Install the brake drum. See *Brake Drum Removal and Installation*.

BRAKES

Read all of SAFETY and this section before attempting any procedure. Pay particular attention to Notices, Cautions, Warnings and Dangers.

Repeat on other side of vehicle. Adjust the brake pedal free travel. See *Adjusting Brake Pedal Free Travel*.

Brake Cable and Equalizer Assembly Removal and Installation

NOTICE: The brake cables and equalizer are only serviceable as a complete assembly.

Remove the cotter pins and clevis pins connecting the brake cables to the brake levers. Remove the retaining rings connecting the brake cables to their brackets at the axle (rear of cable) and at the frame (front of cable). Loosen and remove the jam nut and the spherical nut on the equalizer link (Figure 27). Inspect the hardware and replace if needed. Remove the brake cable and equalizer assembly and discard.

Slide the equalizer link of the new assembly over the compensator rod. Loosely install the spherical nut and new locking jam nut. Insert the cables into the frame and axle brackets. Install new retaining rings. Connect the cables to the brake levers using new clevis pins and new cotter pins.

Adjust the brake pedal free travel. See *Adjusting Brake Pedal Free Travel*.

Loosen and remove the jam nut and the spherical nut connecting the compensator rod to the equalizer link. Remove the compensator assembly.

Installation is the reverse of removal. Use new cotter pin in the clevis pin.

Adjust the brake pedal free travel. See *Adjusting Brake Pedal Free Travel*.

Brake Pedal Removal and Installation

Disconnect the compensator assembly (1) from the brake pedal by removing the cotter pin (2) and the clevis pin (3) (Figure 28).

Disconnect the wiring harness if equipped with brake lights.

Unhook the torsion spring (4) by inserting a thin blade screwdriver between the small hook and the bracket. Move hook back and to the side to release torsion spring.

Remove the nut (5), washer (11) and the shoulder bolt (6).

Remove the brake pedal.

Inspect the shoulder bolt for corrosion that could cause binding. Replace both bolts and two bushings (7) with new ones if corrosion or wear is found.

Brake pedal installation is in the reverse order of removal.

Tighten the nut (5) to the torque value specified below.

Item	Torque Specification
5	8 - 11 ft. lbs. (11 - 15 Nm)

Use a new cotter pin when installing the compensator assembly.

Connect the brake light wiring harness, if equipped.

Adjust the brake pedal free travel. See *Adjusting Brake Pedal Free Travel*.

Check brake light operation if equipped.

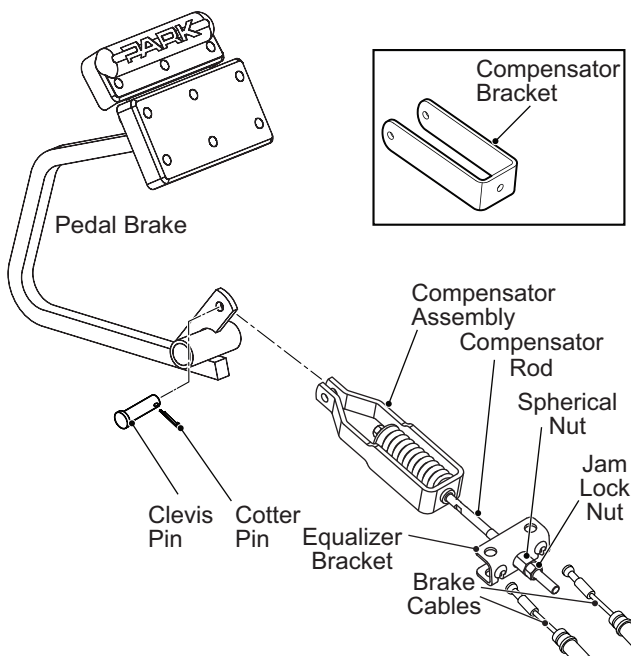

Figure 27 Brake Cable, Equalizer and Compensator

Compensator Assembly, Removal and Installation

Disconnect the compensator assembly from the brake pedal by removing the cotter pin and clevis pin (Figure 27).

Read all of SAFETY and this section before attempting any procedure. Pay particular attention to Notices, Cautions, Warnings and Dangers.

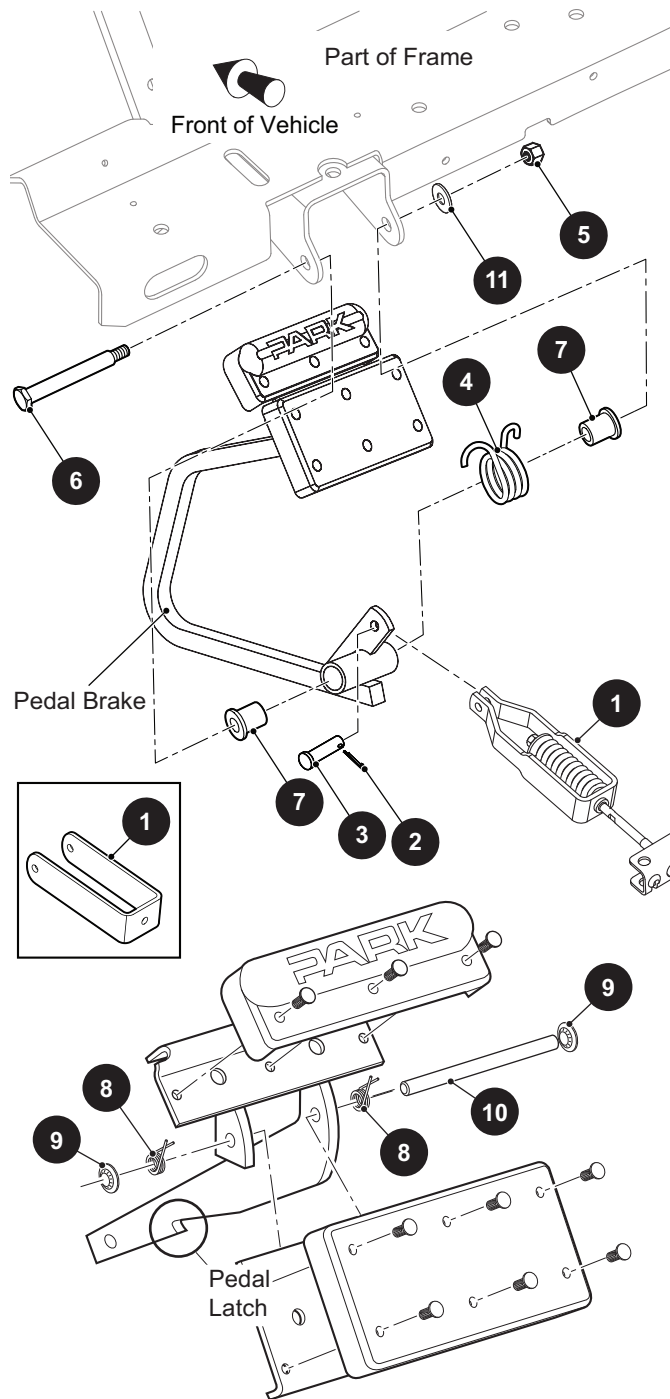

Figure 28 Brake Pedal Removal and Installation

Parking Brake Catch Bracket Removal and Installation

Remove the driver side front wheel to access the brake pedal release mechanism.

⚠ WARNING *To prevent serious injury or death resulting from the use of worn parking brake components, do not attempt to re-new worn components. The catch bracket is a hardened part. Do not grind or file it, as doing so will cause the part to lose its hardness characteristics. Always use a new catch bracket.*

Remove the two bolts (1) and nuts (2) that secure the catch bracket. Replace the new catch bracket.

Tighten the hardware to the torque value specified below (Figure 29).

Item	Torque Specification
2	85 - 95 in. lbs. (10 - 11 Nm)

If required, adjust the kick-off cam (3). See *Parking Brake Kick-Off Cam Removal, Replacement and Installation*.

Install the wheel. See WHEELS AND TIRES section.

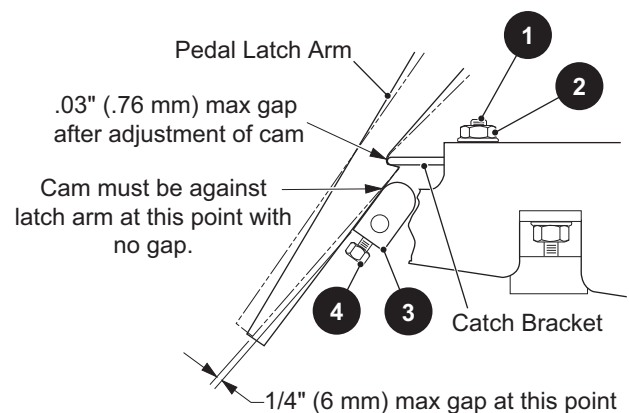

Figure 29 Catch Bracket and Latch Arm

Parking Brake Pedal Removal and Installation

Note the location and orientation of the two torsion springs (8) for reassembly purposes. Remove the push nut(s) (9) and pin (10) (Figure 28) and remove the parking brake pedal.

⚠ WARNING *To prevent serious injury or death resulting from the use of worn parking brake components, do not attempt to re-new worn components. The parking brake arm latch is a hardened part. Do not grind or*

BRAKES

Read all of SAFETY and this section before attempting any procedure. Pay particular attention to Notices, Cautions, Warnings and Dangers.

file it, as doing so will cause the part to lose its hardness characteristics. Always use a new parking brake arm latch.

Install the parking brake pedal in reverse order of removal. Use a new push nut (or push nuts).

If required, adjust the kick-off cam (3). See *Parking Brake Kick-Off Cam Removal, Replacement and Installation*.

Pedal Bumper Adjustment

Loosen the bumper lock nut and adjust the bumper by rotating it (Figure 30). The brake pedal must contact the pedal bumper when the pedal is released. The dimension from the top of the pedal arm to the setscrew heads in the kick-off cam should be $1/4" - 3/8"$ (6 - 9.5 mm).

When correctly adjusted, tighten the lock nut to the torque value specified below.

Item	Torque Specification
Lock Nut	12 - 14 ft. lbs. (16 - 19 Nm)

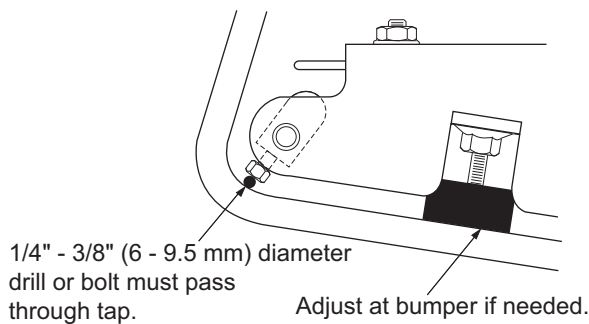

Figure 30 Pedal Bumper Adjustment

Parking Brake Release Linkage Removal and Replacement

Remove the cotter pin (2), washers (3) and bushings (4) from the linkage rod (1). Remove the linkage rod (Figure 31).

Inspect the bushings (4). Replace them if signs of wear are present.

Install in reverse order of removal.

If required, adjust the kick-off cam (6). See *Parking Brake Kick-Off Cam Removal, Replacement and Installation*.

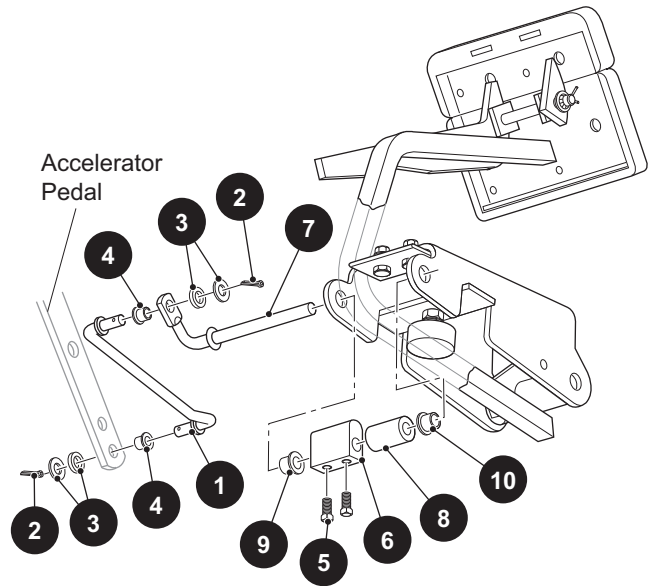

Figure 31 Parking Brake Release Linkage and Kick-Off Cam Removal and Installation

Parking Brake Kick-Off Cam Removal, Replacement and Installation

Disconnect the parking brake release linkage as described above. Loosen the two set screws (5) from the cam (6) and remove the cam pivot (7), cam and spacer (8) (Figure 31).

Inspect the bushings (9,10) and spacer. Replace any that show signs of wear.

Install in reverse order of removal.

With the parking brake engaged and completely locked, there must be no gap between the top of the cam and the latch arm.

To adjust the kick-off cam (6), engage the parking brake, loosen the two cam setscrews (5) and rotate the cam until it contacts the latch arm.

Tighten the set screws (5) to the torque value specified below. Always use new set screws with a locking patch.

Item	Torque Specification
5	70 - 84 in. lbs. (8 - 9.5 Nm)

FRONT HYDRAULIC BRAKES

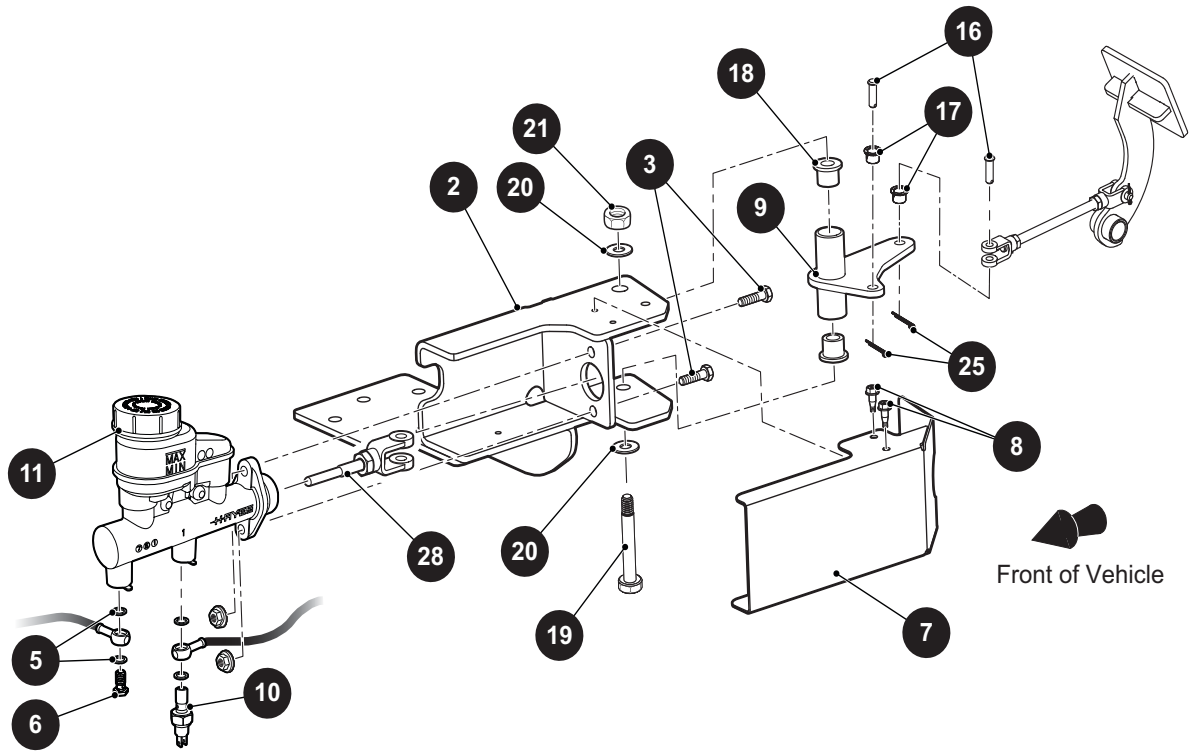

Figure 1 Master Cylinder Replacement

Front hydraulic brakes are optional, therefore may not be present on all vehicles.

SYSTEM DESCRIPTION

NOTICE: To ensure correct braking performance, all periodic maintenance, inspections and procedures must be performed as indicated in the Scheduled Maintenance section.

The brake system must be bled whenever any part of the brake system has been replaced.

A hydraulic system is used to actuate the front brakes. The system transmits the power needed to activate the friction surfaces (pads) of the braking system from the pedal to each disc brake hubs at each wheel.

The front hydraulic brake system is designed to operate only after significant rear brake pressure has been applied. This occurs by activation of the master cylinder, after the brake pedal has reached the park brake latch position. The lower actuator pivot is connected to the brake pedal by a linkage rod which rotates to contact the upper actuator pivot. The upper actuator pivot is connected to a clevis on the master cylinder plunger. Movement of the plunger hydraulically activates the caliper pistons, forcing the brake pads against the rotors. With

the brake pedal released, the upper actuator pivot and the plunger returns to the 'at rest' position. With the master cylinder no longer applying hydraulic pressure to the brake pistons, the piston seals retract the pistons permitting the brake pads to float freely against their guide pins while removing all pressure against the rotors.

MASTER CYLINDER REPLACEMENT

CAUTION When this procedure is performed, it is likely that brake fluid will leak from the master cylinder. Do not allow brake fluid to contact painted body panels. If it occurs, wipe off immediately.

NOTICE: Removing the front shield may improve accessibility to brake components. (See BODY section).

Remove Master Cylinder

Remove the master cylinder cover (7) after removing the bolt (8) (Figure 1).

Remove the cotter pin (25) from clevis pin (16) securing the upper actuator pivot (9) and master cylinder clevis (28).

FRONT HYDRAULIC BRAKES

Read all of SAFETY and this section before attempting any procedure. Pay particular attention to Notices, Cautions, Warnings and Dangers.

Remove the banjo bolt (6), crush washers (5) and pressure switch (if equipped) (10) securing the brake line to the master cylinder (11). Remove the braided brake line (not shown in illustration) from the master cylinder (11) and allow brake fluid to drain into a container. Discard fluid. **Do not reuse old brake fluid.**

Remove the bolts (3) securing the master cylinder to the master cylinder housing bracket (2).

Install Master Cylinder

Install the new master cylinder (1) using, bolt (3) nuts (4) as shown in (Figure 1). Tighten nuts (4) to torque value specified below.

Item	Torque Specification
4	12 - 15 ft. lbs. (16 - 20 Nm)

Install the new master cylinder (11) and brake line using banjo bolts (6), crush washers (5) and pressure switch (if equipped) (10) and tighten the bolts (6) and pressure switch (if equipped) (10) to 20 - 22 ft. lbs. (27.1 - 29.8 Nm) torque.

Latch the parking brake pedal.

Rotate and hold the upper actuator pivot (9). Adjust the master cylinder clevis (28) until the clevis pin (16) can be installed.

Tighten the jam nut against the master cylinder clevis.

Install a new cotter pin (25). Bleed the hydraulic system.

Add clean, fresh DOT 3 brake fluid into reservoir. Bleed system as instructed in See the *BLEEDING BRAKES* on page 55.

MASTER CYLINDER FLUID

NOTICE: Hydraulic brake systems must be totally flushed if the fluid becomes contaminated with water, dirt or other corrosive chemicals.

Flush Hydraulic Brake System

Bleed the entire system until all brake fluid is removed. Replace with fresh DOT 3 standard automotive brake fluid.

Check Brake Fluid

The brake fluid must be checked at regular intervals (as specified in the Periodic Service Schedule) or immediately when fluid leaks are found.

Clean the cap with a shop rag and remove the cap from the master cylinder. Use a mechanics mirror and a flashlight to check the fluid level. Add fluid if level is below 1/4" (6.5 mm) from the top of the reservoir. Inspect for visible fluid leaks.

ROUTINE MAINTENANCE

Tool List	Quantity
Shop Rag	AR
Mechanics Mirror	1
Flashlight	1
Transmission Fluid Funnel	1
Torque Wrench, ft. lbs.	1
Torque Wrench, in. lbs.	1
Crows Foot 9/16", 3/8" drive	1
Open End Wrench, 3/8"	1
Open End Wrench, 1/2"	1
Open End Wrench, 5/8"	1
Open End Wrench, 9/16"	1
Needle Nose Pliers	1
Ratchet	1
Sockets, 3/8"	1
Sockets, 1/2"	1
Sockets, 5/8"	1
Sockets, 9/16"	1
Micrometer/Vernier Caliper	1
2" C Clamp	1
Floor Jack	1
Jack Stands	1
Ball Joint Separator	1
Lug Wrench, 3/4"	1
Jack	1
Jack Stands	4
Brake Adjusting Tool	1
Plastic Faced Hammer	1

WARNING Never work on a vehicle that is supported by a jack alone. To decrease the risk of personal injury, the vehicle must be supported on jack stands during procedures that require lifting.

FRONT HYDRAULIC BRAKES

Read all of SAFETY and this section before attempting any procedure. Pay particular attention to Notices, Cautions, Warnings and Dangers.

REPLACEMENT OF WEAR ITEMS

WARNING Wear a dust mask and eye protection when working on wheel brakes.

Do not use pressurized air to blow dust from brake assemblies.

Brake Pad Replacement

NOTICE: Unless fluid is lost or a brake line is disconnected, there is no need to bleed the system to replace brake pads.

The brake pads must always be replaced as a full set of four pads.

Remove old brake pads:

Raise the vehicle per the SAFETY section.

Loosen both of the bolts securing the caliper to the spindle but only remove one. Swing the caliper free from the rotor.

Note the orientation of the brake pads for reassembly purpose. Push out the two guide/retainer pins from the caliper and remove pads.

Install new set of pads:

Position the new pads in the same orientation as the ones removed. If the pads have been correctly positioned, the guide/retainer pins will easily engage. Reinsert the guide/retainer pins, making sure they are correctly seated in the grooves machined in the caliper casting.

Gently push the pads away from each other to provide adequate clearance with the rotor and then swing the entire caliper and pad assembly back over the rotor.

Secure the caliper to the spindle and tighten both bolts to 25 - 30 ft. lbs (33 - 40 Nm) torque.

Rotor Replacement

NOTICE: The rotor (disc brake hub) is not designed to be trued ("turned").

If the rotor has deep grooves or gouges, it must be replaced.

If the pad contact area has worn the rotor to 120" (3 mm) or less, the rotor must be replaced.

Swing the caliper and pads out of the way to gain access to the rotor. See Brake Pad Replacement on page 55.

The disc hub (rotor) can be serviced in the same manner as the hub on non-front disc brake equipped vehicles.

Refer FRONT SUSPENSION AND STEERING section for:

- Hub Replacement
- Wheel Bearing and Race Replacement

- Wheel Bearing Packing
- Wheel Bearing Adjustment

Spindle Replacement

Refer FRONT SUSPENSION AND STEERING section.

Actuator Linkage Bushings

NOTICE: Removing the front shield may improve accessibility to brake components. (Refer BODY section).

Remove cotter pin and washer that secures the lower actuator pivot to the actuator linkage. Discard cotter pin. Retain washer for reuse.

Install a new nylon bushing, flange down, to the lower actuator pivot.

Reconnect the actuator linkage using washer and a new cotter pin.

Actuator Pivot Bushings

NOTICE: Removing the front shield may improve accessibility to brake components. (Refer to the BODY section).

Both the upper and lower actuator pivots contain an acetal flanged bushing at both ends of the actuator and are unlikely to require replacement.

The upper actuator pivot also is fitted with a nylon bushing between it and the brake cylinder clevis. To replace any of these bushings, the actuator linkage must be removed from the lower actuator pivot and the linkage rod. See Actuator Linkage Bushings on page 55.

Remove the cotter pin and clevis pin securing the upper actuator pivot and master cylinder clevis.

Remove the lock nut and shoulder bolt to remove the pivot components.

Bushings may now be removed and replaced with new ones. Be sure to replace the nylon bushing with the flange facing upward.

Reassemble using new cotter pins.

Tighten lock nut to 5 - 10 ft. lbs (7 - 13 Nm) torque.

BLEEDING BRAKES

Tool List	Quantity
Hose	AR
Clean Container	1
Brake Fluid, DOT 3	AR
Box End Wrench, 1/4"	1

FRONT HYDRAULIC BRAKES

Read all of SAFETY and this section before attempting any procedure. Pay particular attention to Notices, Cautions, Warnings and Dangers.

General Information about Bleeding Brakes

The hydraulic brake system must be free of air to operate properly. Air can enter the system when hydraulic parts are disconnected for servicing or replacement, or when the fluid level in the master cylinder reservoir is low. Air in the system gives the brake pedal a spongy feeling when pressed.

NOTICE: An assistant is required to perform this procedure.

Use a clean cloth to wipe off the master cylinder reservoir and wheel cylinder bleeder valves. Clean each fitting before opening to prevent contaminating the system.

Open the master cylinder reservoir and top off with standard automotive DOT 3 brake fluid.

WARNING Never reuse any excess fluid or return to original container. Dispose of brake fluid properly.

Brake fluid should never be returned to the original container and reused due to the possibility of contamination by dirt, grease, moisture or used brake fluid. Contaminated fluid could cause failure of the braking system. Dispose of used fluid in accordance with Federal, state and local codes.

Brake Bleeding Procedure

Attach a short length of clear hose to the caliper bleed valve and insert the other end into a suitable clean container containing fresh, clean brake fluid (Figure 2).

Check the fluid level in the master cylinder frequently during this operation to prevent air from entering the lines.

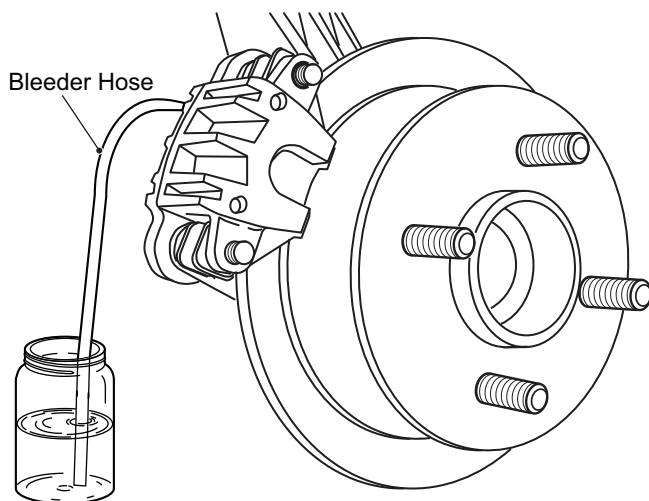

Figure 2 Bleeding Brakes

Start with the passenger side rear brake and move to the driver side rear brake, bleed the brakes using the following procedure:

NOTICE: The bleeder valve at the caliper must be closed at the end of each stroke and before the brake pedal is released to ensure air cannot enter the system.

It is important that the brake pedal be returned to full 'up' position.

1. Open the bleeder valve and have an assistant press brake pedal gently until fluid flows into container.
2. Close the bleeder valve and have the assistant slowly release the brake pedal.
3. Repeat the process until no bubbles can be seen leaving the bleeder valve.
4. Close the valve and repeat at other side.
5. After bleeding, check fluid level using a mechanics mirror and a flashlight.
6. Add fluid if the level has fallen below 1/4" (6.5 mm) from the top of the reservoir.
7. Inspect for visible fluid leaks.

FRONT HYDRAULIC BRAKES

Read all of SAFETY and this section before attempting any procedure. Pay particular attention to Notices, Cautions, Warnings and Dangers.

FRONT HYDRAULIC BRAKES

Read all of SAFETY and this section before attempting any procedure. Pay particular attention to Notices, Cautions, Warnings and Dangers.

REAR HYDRAULIC BRAKES

SYSTEM DESCRIPTION

NOTICE: To ensure correct braking performance, all periodic maintenance, inspections and procedures must be performed as indicated in the SCHEDULED MAINTENANCE section of this manual. The brake system must be bled whenever any part of the brake system has been replaced.

A hydraulic system is used to actuate the front disc brakes and the rear drum brakes. The system transmits the power required to activate the friction surfaces (pads and shoes) of the braking system from the pedal to the individual wheels.

Daily Brake Performance Test

NOTICE: To assure correct braking performance, all periodic maintenance, inspections and procedures must be performed as indicated in the Scheduled Maintenance section of this manual. It is important that Daily Brake Performance Test be performed and the entire brake system be serviced in accordance with the Scheduled Maintenance.

The brake system must be bled whenever any part of the brake system has been replaced.

Press brake pedal. The pedal should have some free play and then become hard. A brake pedal that has no free travel, excessive free travel or a spongy feel indicates a brake inspection is required. A brake pedal that falls after it is applied indicates a leak in the master or wheel cylinders. Check brake fluid level. Adjust brakes if required and inspect system for fluid leaks.

Brake System Inspection

Brake failure usually occurs as either a gradual decrease in braking effect from the shoe material being worn away, a loss of braking at one wheel or a sudden and complete failure with no brakes working except the parking brake.

Inspect front and rear brakes for signs of fluid leakage. Inspect rear brake shoes and front disc pads for wear.

NOTICE: Care should be taken to prevent brake fluid from coming into contact with the brake shoes. If the brake shoes should become wet with hydraulic fluid, remove the brake drum and wipe the brake shoes and drum until they are dry.

Complete brake failure usually indicates a loss of hydraulic fluid pressure.

The hydraulic system may be checked for leaks by applying pressure to the pedal gradually and steadily. If the pedal sinks very slowly to the floor, the system has a leak. This is not to be confused with a springy or spongy feel due to the compression of air within the lines.

Check for leaks along all lines and at brake assembly. If no external leaks are apparent, the problem is inside the master cylinder.

CAUTION Do not allow brake fluid to contact painted surfaces. Wipe off immediately.

After making any repairs to hydraulic lines, wheel cylinders or master cylinder, the brakes must be bled to remove any trapped air. A bleeder valve is located at each wheel cylinder for this purpose.

To assure correct braking performance, all periodic maintenance, inspections and procedures must be performed as indicated in the SCHEDULED MAINTENANCE section of this manual. The brake system must be bled whenever any part of the brake system has been replaced, refer to BLEEDING BRAKES in BRAKES section.

BRAKE DRUM REMOVAL AND INSTALLATION

Tool List	Quantity
Slip Joint Pliers	1
Needle Nose Pliers	1
Socket, 1 1/8", 1/2"	1
Ratchet	1
Plastic Faced Hammer	1
Drum Puller (P/N 15947G1).....	1
Wrench, 7/16"	1
Anti-seize Compound	AR
Torque Wrench, ft. lbs.	1

WARNING The drum must not be machined to remove grooves. Turning will make the drum too thin causing drum and brake failure which could cause severe injury or death.

Wear a dust mask and eye protection whenever working on wheel brakes. Do not use pressurized air to blow dust from brake assemblies.

NOTICE: Do not apply the brake when removing the nut as the shoes may not fully retract preventing removal of the brake drum.

Pay particular attention to the location of the brake drum washer inside the brake drum, which may be on the axle shaft or attached to the rear of the drum hub. This washer must be reinstalled when the brake is reassembled.

Remove spindle cap to gain access to the castellated nut and the cotter pin.

Remove the cotter pin and castellated nut (Figure 1).

REAR HYDRAULIC BRAKES

Read all of SAFETY and this section before attempting any procedure. Pay particular attention to Notices, Cautions, Warnings and Dangers.

Remove brake drum washer.

Slide the brake drum and hub assembly from the axle shaft. If required, tap the drum with a plastic faced hammer to loosen it from the axle shaft or use drum puller (P/N 15947G1). If shoes interfere with drum removal, rotate adjuster bolt on back side of backing plate towards the axle to retract shoes and remove brake drum.

To install the brake drum, clean the axle shaft and the splines on the brake drum to remove dirt, grease and foreign matter. Apply a small amount of anti-seize compound to the axle spline. Install the brake drum washer and slide the brake drum into place. Check to ensure the nose of drum hub is beyond the end of the axle splines. If not, remove drum and install one additional inner brake drum washer (total of 2) to obtain required spacing. If two inner brake drum washers do not provide the required

spacing, the brake drum is incorrect and must be replaced with a new drum.

CAUTION Do not back off nut to install cotter pin.

Install the remaining hardware and tighten the castellated nut to specified torque value. Continue to tighten until a new cotter pin can be installed through the castellated nut and the hole in the axle. Do not torque more than the maximum torque specified.

Item	Torque Specification
Castellated Nut	80 - 90 ft. lbs. (108 -122 Nm)

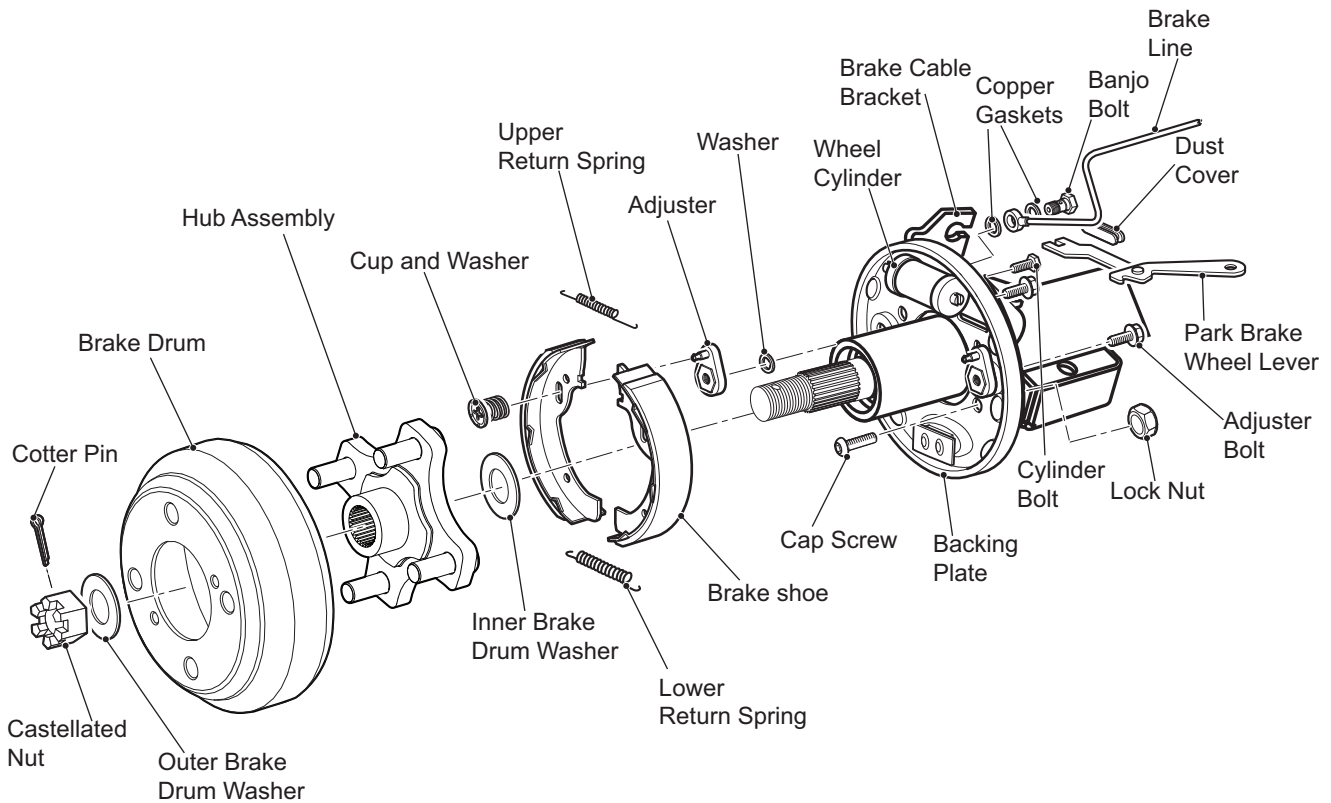

Figure 1 Wheel Brake Components

REAR HYDRAULIC BRAKES

Read all of SAFETY and this section before attempting any procedure. Pay particular attention to Notices, Cautions, Warnings and Dangers.

WHEEL BRAKE SERVICE

Tool List	Quantity
Dust Mask	1
Safety Glasses	1
Socket, 3/4"	1
Ratchet	1
Wheel Chocks	4
Hydraulic Floor Jack	1
Jack Stands	2
Brush	1
Wheel Cylinder Clamp	1
Pliers	1
Wrench, 9/16"	1
Wrench, 10 mm	1
Shop Towels	AR
Socket, 7/16", 3/8"	1
Torque Wrench, in. lbs.	1
Wire Brush	1
Grease	AR
High Temperature Lubricant	AR
Socket, 10 mm, 3/8"	1
Socket, 9/16", 3/8"	1
Locking Pliers	1
Thread Locking Compound	AR

⚠ WARNING *Wear a dust mask and eye protection whenever working on wheel brakes. Do not use pressurized air to blow dust from brake assemblies. Replace both brake shoes on both wheels if one or more shoes are worn below .06" (1.5mm) thickness at any point.*

⚠ CAUTION *Do NOT touch any of the wheel brake mechanism except as instructed.*

Do NOT use a commercial brake cleaner unless the entire brake has been disassembled.

Be sure that the parking brake is released.

Loosen rear wheel lug nuts and lift rear of vehicle as per SAFETY section. Remove wheel, wheel drum and hub assembly (Figure 1). Refer to 'Brake Drum Removal and Installation' in this section. Remove excess dust and dirt from the drum with a brush.

Remove any accumulated brake dust from the wheel brake assembly with a brush.

Install wheel cylinder clamp, then unhook upper and lower shoe to shoe springs.

Remove parking brake strut and lever.

Remove shoe hold-down springs and remove shoes.

If the wheel cylinder must be removed, begin by loosening and removing the brake line from the back of the wheel cylinder. Next remove the wheel cylinder bolts and remove the wheel cylinder from the backing plate.

Cleaning and Inspection

⚠ WARNING *The drum must not be machined to remove grooves. Turning will make the drum too thin causing drum and brake failure which could cause severe injury or death.*

A backing plate assembly that shows any indication of galling or gouging is not repairable and must be replaced with a new wheel brake assembly. Always replace wheel brake assemblies in pairs.

Inspect the brake drum. Look for a blue coloration or blistered paint that would indicate that it has overheated. Check for evidence of scoring. Check for excessive wear indicated by the friction surface being significantly worn and leaving a ledge of unworn drum. Inspect the splines for galling, wear and corrosion. If any of these problems are found, the drum must be replaced.

Visually inspect the axle seal for oil leakage and the condition of the thrust washer. If oil is present, refer to REAR AXLE section.

Verify the inner brake drum washer is present and check its condition. Replace if damaged or missing.

Clean the backing plate with an approved cleaner for this purpose.

⚠ WARNING *A backing plate assembly that shows any indication of galling or gouging is not repairable and must be replaced with a new wheel brake assembly. Always replace wheel brake assemblies in pairs.*

Inspect the backing plate. Inspect for gouges, galling or other damage, particularly where the backing plate is contacted by the brake shoes. Be sure shoe ledges are smooth and free of rough edges. Replace both wheel brake assemblies if any gouges or galling is found.

Measure the brake shoe thickness. Measure at the most worn area. Brake shoe thickness must never be less than .06" (1.5 mm) at any point on the shoe. It is normal for the shoes to show more wear at the leading and trailing edges. If the brake shoe thickness is approaching .06" (1.5 mm), it is recommended that the shoes be replaced. It is recommended that the brake shoe springs and brake adjusters be replaced when installing new brake shoes.

Check springs for loss of tension and damage. Replace weak springs and any damaged or badly worn parts.

Check adjuster operation. Ensure that each adjuster will move with approximately 30 - 50 in. lbs. (3.4 - 5.6 Nm) of torque. If adjusters are frozen, badly worn or loose, replace the adjuster assembly.

Replace the wheel cylinder if there is any sign of leakage.

Ensure that the parking lever and strut assembly can be easily moved by hand. If necessary, this assembly can be serviced as follows:

REAR HYDRAULIC BRAKES

Read all of SAFETY and this section before attempting any procedure. Pay particular attention to Notices, Cautions, Warnings and Dangers.

Disassemble by removing the C-clip. Wire brush contact surfaces to remove any corrosion and contaminants. Lightly grease the pin and contact surfaces before re-assembly.

⚠ WARNING *Ensure that the C-clip is completely seated in its' groove when finished. Failure to do so could result in a non-functioning parking brake if the clip comes off.*

Reassembly

Apply a light coat of high temperature lubricant to shoe support points on the backing plate, to adjuster pin, and to anchor.

Position the adjusters so that the pins are at the 12 o'clock position.

If the wheel cylinder was removed, install it now into the backing plate. Insert the wheel cylinder mounting bolts and torque to specific torque value. Reconnect the brake fluid line using new copper gaskets and banjo bolts.

Tighten the banjo bolts to specific torque value.

Item	Torque Specification
Cylinder Bolt	120 in. lbs. (14 Nm)
Banjo Bolt	124 - 177 in. lbs. (14 - 20 Nm)

Position shoes on backing plate and install hold-down springs.

Install parking brake strut with tab on strut engaged in brake shoe web.

Place upper end of shoe webs against wheel cylinder, and install upper shoe-to-shoe spring.

Remove wheel cylinder clamp.

Install lower shoe-to-shoe spring.

Install wheel drum, hub assembly and wheel. See "Brake Drum Removal and Installation" in this section.

Pre-adjust shoes by rotating adjuster nut away from the axle until shoes contact drum and then back off just enough to eliminate drag.

FRONT SUSPENSION AND STEERING

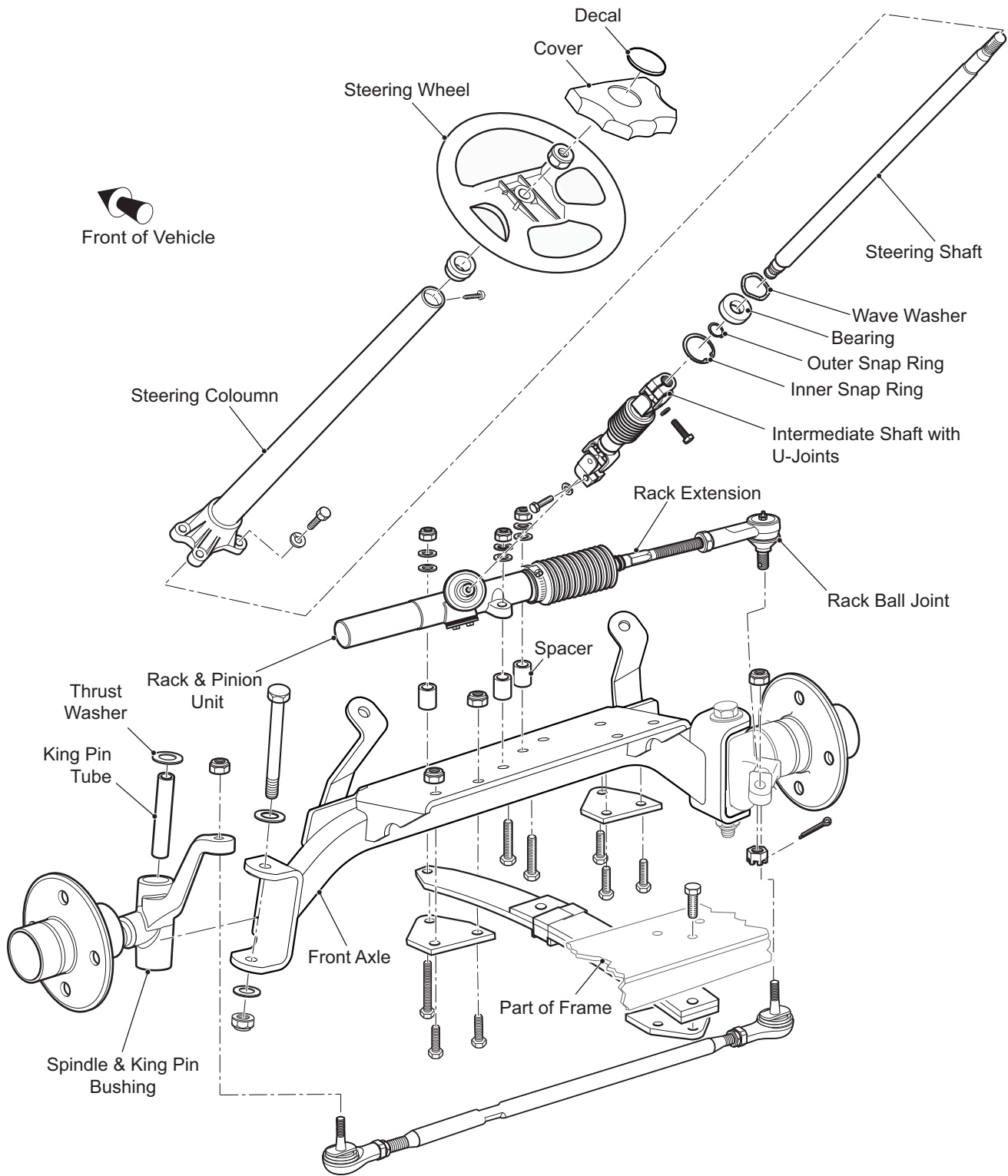

Figure 1 Axle Mounted Steering and Front Suspension Components

FRONT SUSPENSION AND STEERING

Read all of SAFETY and this section before attempting any procedure. Pay particular attention to Notices, Cautions, Warnings and Dangers.

MAINTENANCE

NOTICE: Hardware that is removed must always be installed in its original position unless otherwise specified. If torque values are not specified, refer to the Torque Specifications table in the GENERAL INFORMATION AND ROUTINE MAINTENANCE section.

Routine maintenance of the front suspension and steering consists of:

- periodic inspections for loose, worn or damaged components
- alignment checks
- lubrication of ball joints and wheel bearings

See Lubrication Points in GENERAL INFORMATION & ROUTINE MAINTENANCE section and Periodic Service Schedule Table in PERIODIC SERVICE SCHEDULE section. Maintain correct adjustment of the front wheel bearings. Repack in accordance with the Periodic Service Schedule or if a bearing replacement is required. Routine examination of the tires will indicate if an alignment is required.

Lubrication

Tool List

	Quantity
Grease Pump	1
Shop Towels	AR

Apply grease to the rack ball joint (1) as indicated in the Periodic Service Schedule (Figure 2).

1. Wipe off old grease and dirt from the grease fitting.
2. Do not use more than three (3) pumps of grease in any grease fitting.
3. Wipe off any grease that is forced out of the rubber boot.

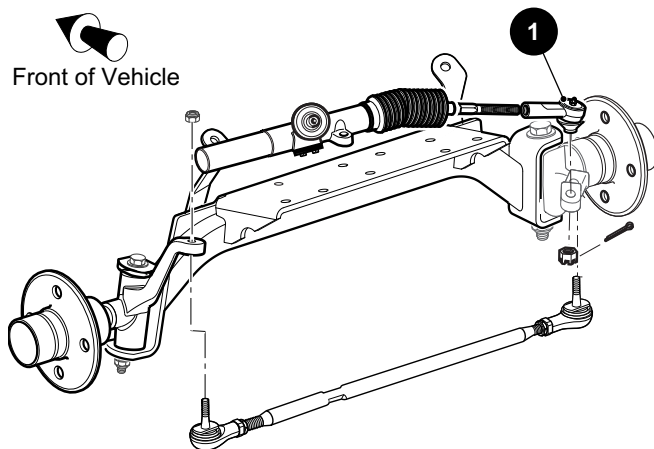

Figure 2 Lubrication Points

CAUTION Do not use more than three (3) pumps of grease in any grease fitting at one time. Excess grease may cause grease seals to fail or grease migration into areas that could damage components.

Wheel Bearing and King Pin Bushing Inspection

WARNING To decrease the risk of possible injury or death resulting from a vehicle falling from a jack, follow the lifting procedure in SAFETY section of this manual. Be sure the vehicle is on a firm, level surface.

Never get under a vehicle while it is supported by a jack. Use jack stands to support the vehicle. Test the stability of the vehicle on the stands before starting any repair procedure. Always place chocks in front and behind the wheels that are not being raised. Use extreme care since the vehicle is extremely unstable during the lifting process.

1. Lift and support the front of the vehicle as instructed in the SAFETY section. Observe all warnings.
2. Rotate the front wheel and feel for any roughness.
3. While holding spindle with one hand, grasp bottom of tire with other hand and rock tire back and forth on the spindle.

NOTICE: Some minor rocking movement of the wheel is normal.

If excess movement is detected, the wheel bearing may require repacking/adjusting or replacement. For instructions on wheel bearing packing and wheel bearing adjustment, refer to "Wheel Bearing Packing" section of the manual.

If the wheel bearing is in good condition, a worn spindle bearing is indicated. The spindle bearings cannot be replaced. Spindles with pre-installed bearings are available through service parts. See Spindle Replacement.

Wheel Bearing Packing

Tool List

	Quantity
Grease Pump	1
Bearing Packer (Recommended)	1
Shop Towels	AR

1. Remove the hub from the spindle and disassemble. See Pinion Seal Replacement. (Figure 9).
2. Clean all bearings, grease seals, hubs and dust caps in solvent and dry thoroughly.
3. Inspect for signs of damage. Pitting or a blue coloration of the rollers will require replacement of the bearing. If the roller portion of the bearing is to be replaced, the race must also be replaced. See Pinion Seal Replacement. (Figure 9).

FRONT SUSPENSION AND STEERING

Read all of SAFETY and this section before attempting any procedure. Pay particular attention to Notices, Cautions, Warnings and Dangers.

4. The front wheel bearings are a tapered roller type and must be packed with grease at installation or any time the bearing is removed for inspection. It is recommended that a bearing packer attached to a grease pump be used; however, manual packing is acceptable if done correctly. To pack a bearing manually requires a dab of grease be placed in the palm of the hand and the bearing dipped into the grease. Force the grease up through and around all of the rollers until the entire bearing is saturated in grease.
5. To install hub on spindle. See Hub Replacement.

NOTICE: Once the hub is placed onto the spindle and before the outer wheel bearing is installed, fill the area between the inner and the outer wheel bearings 1/2 - 3/4 full with grease.

Wheel Bearing Adjustment

Tool List	Quantity
Socket, 1 1/2"	1
Ratchet	1

1. If performing a wheel bearing adjustment only, lift and support the front of the vehicle as instructed in the SAFETY section. Observe all warnings.
2. Remove the dust cap (1) and the cotter pin (2).
3. Loosen the castellated nut (3). (Figure 3).
4. If performing a wheel bearing adjustment as part of another procedure, make sure the wheel is mounted to the hub hand tight with lug nuts (4), and the hub is loosely retained on the spindle (5) with the castellated nut (Figure 3).
5. Seat the bearings by rotating the wheel while tightening the castellated nut until slight resistance is felt.
6. Rotate the wheel two to three more turns to displace excess grease. If required, tighten the castellated nut (3) again until slight resistance is felt. If the cotter pin hole in the spindle (5) aligns with a slot in the castellated nut, insert a new cotter pin (2). If the hole does not align, **loosen** the castellated nut to align with the **closest available** slot in the nut.
7. Check for smooth and free rotation of the wheel, and an absence of play when the wheel is grasped by the outside of the tire. Bend the cotter pin (2) against the flats of the castellated nut (3).
8. Replace the dust cap (1) and lower the vehicle as instructed in the SAFETY section.
9. If completing a wheel bearing adjustment as part of another procedure, tighten the front wheel lug nuts as instructed in the WHEELS AND TIRES section.

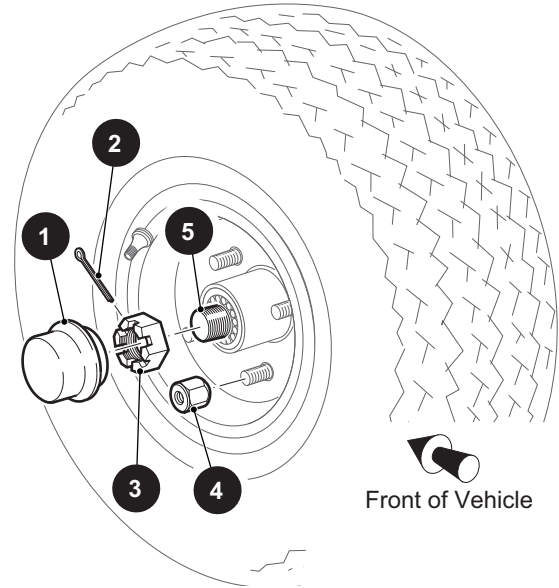

Figure 3 Bearing Adjustment

Wheel Alignment

Tool List	Quantity
Tape Measure	1
Chalk	1
Wrench, 9/16"	1
Wrench, 3/4"	1
Crowfoot Socket, 3/4"	1
Torque Wrench, ft. lbs.	1
Socket, 13 mm,	1
Ratchet	1
Torque Wrench, in. lbs.	1

1. Confirm the alignment of the front springs. See Front Spring Replacement.
2. Rotate each wheel and scribe a chalk line around the circumference of the tire at the center of the tread pattern.
3. Lift and support the front of the vehicle as instructed in the SAFETY section. Observe all warnings.
4. With the wheels in the straight ahead position, roll the vehicle forward approximately five feet in order to allow the wheels to take their normal running position.
5. Measure the distance between the chalk lines at both the front and rear of the tires (Figure 4). The measurement taken at the front of the tires should be 0" - 1/8" (0 - 3 mm) less than the rear.

FRONT SUSPENSION AND STEERING

Read all of SAFETY and this section before attempting any procedure. Pay particular attention to Notices, Cautions, Warnings and Dangers.

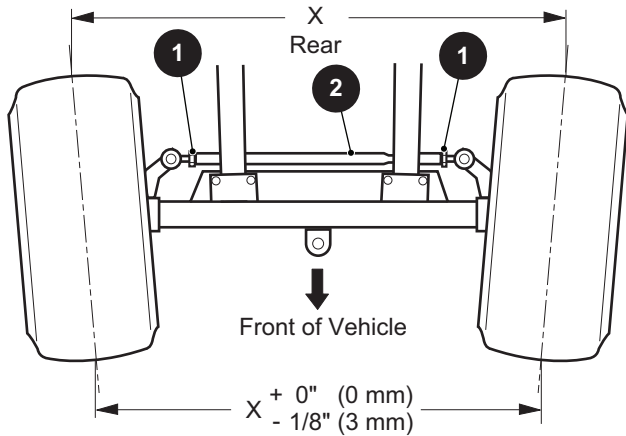

Figure 4 Wheel Alignment

NOTICE: Use a wrench on the center, flat section of the tie rod while loosening the jam nut. The tie rod has different threads on each end. The end with the flat area has left hand threads (clockwise to loosen) while the end without the flat has conventional right hand threads (counter-clockwise to loosen).

6. To adjust the wheel alignment, loosen the tie rod jam nuts (1) and turn the tie rod (2) until the correct alignment is achieved (Figure 5).
7. Tighten the jam nuts (1) to the torque value specified below.

Item	Torque Specification
1	36 - 40 ft. lbs. (49 - 54 Nm)

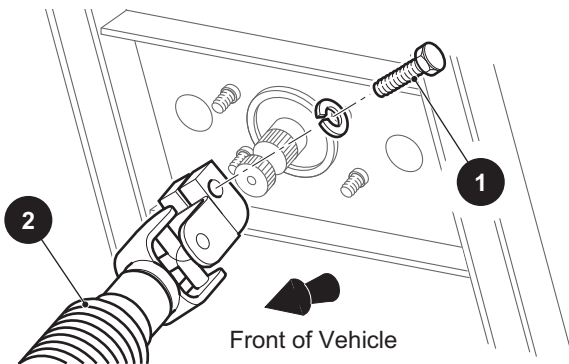

Figure 5 Disconnect Intermediate Shaft to Center Steering Wheel

8. Test drive the vehicle to confirm the steering wheel is correctly centered. If it is not centered, remove the bolt (1) to disconnect the intermediate shaft (2) from

the steering shaft and center the steering wheel (Figure 5).

9. Reconnect the intermediate shaft and tighten the bolt (1) to the torque value specified below.

Item	Torque Specification
1	13 - 18 ft. lbs. (18 - 24 Nm)

FRONT SUSPENSION AND STEERING

Read all of SAFETY and this section before attempting any procedure. Pay particular attention to Notices, Cautions, Warnings and Dangers.

FRONT SUSPENSION

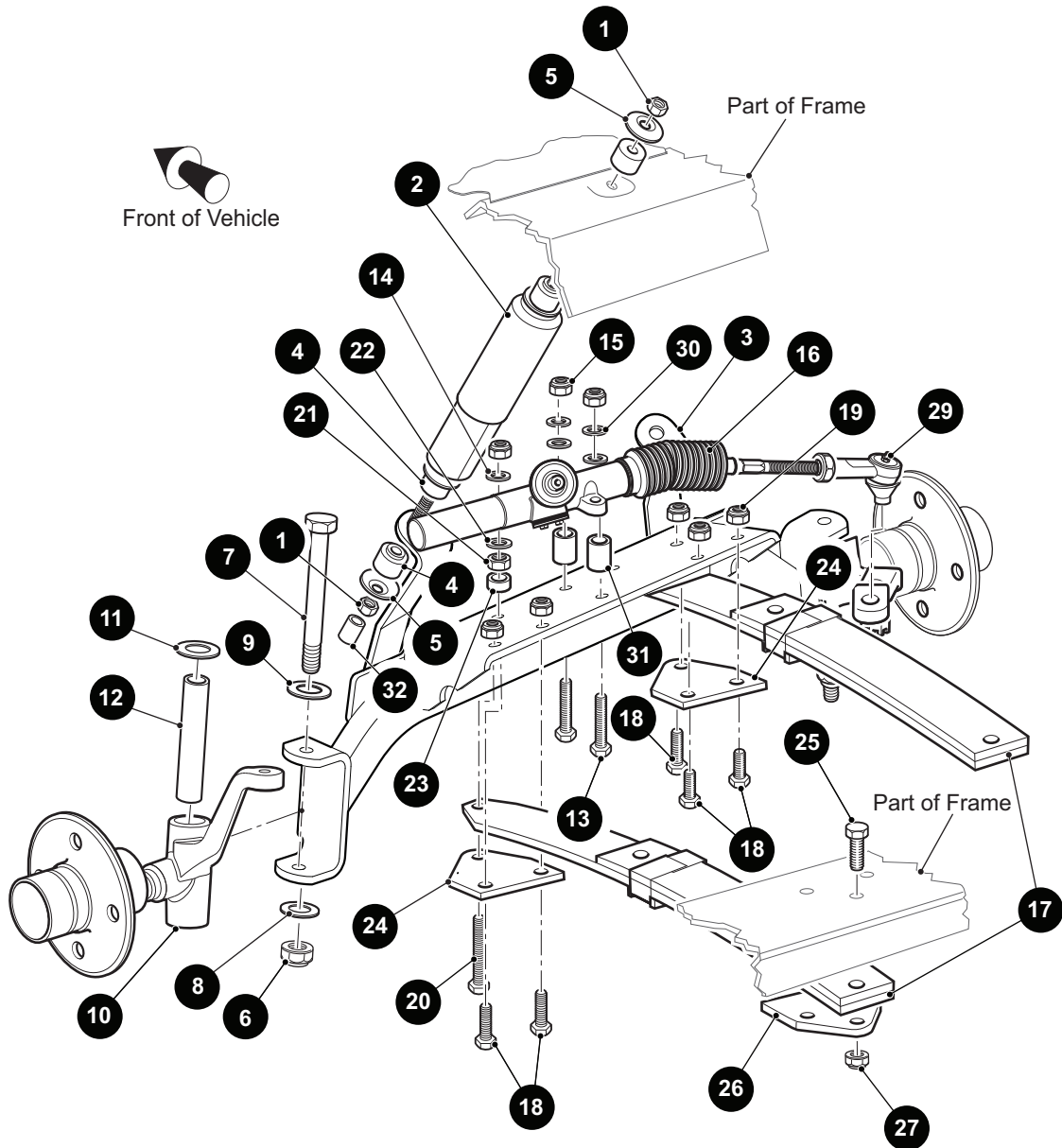

*NOTE: Tie Rod Not Shown for Clarity

Figure 6 Front Suspension Components

Front Shock Absorber Replacement

Tool List

Wrench, 9/16" 1

Quantity

1. Remove the vinyl cap (32) from the bottom of the shock absorber (2) and nuts (1) from the bottom and top of the shock absorber (2) at the front axle (3) (Figure 6).

2. Compress the shock absorber to clear the mounting bracket.
3. Loosen the nut (1) securing the top of the shock absorber to the vehicle frame and rotate the shock absorber while holding the nut in place with a wrench.
4. Remove the shock absorber.

FRONT SUSPENSION AND STEERING

Read all of SAFETY and this section before attempting any procedure. Pay particular attention to Notices, Cautions, Warnings and Dangers.

- Install the shock absorber in the reverse order of removal. Mounting nuts (1) should be tightened until the rubber bushings (4) expand to the diameter of the shock absorber washers (5).

Front Axle Replacement

Tool List	Quantity
Ratchet	1
Socket, 3/4"	1
Wrench, 9/16"	1
Wrench, 3/4"	1
Plastic Faced Hammer	1
Shop Towels	AR
Wire	AR
Wrench, 5/8"	1
Wrench, 11/16"	1
Socket, 9/16"	1
Socket, 5/8"	1
Torque Wrench, ft. lbs.....	1

- Loosen the front wheel lug nuts.
- Lift and support the front of the vehicle as instructed in the SAFETY section. Observe all warnings.
- Remove the lug nuts and the front wheels.
- Remove the hardware (1, 4, 5, 32) securing the shock absorbers (2) to the front axle (3) (Figure 6).
- On the driver side, remove the lock nut (6) and washer (8) from the bolt (7); discard the nut (6). Remove the bolt (7) and washer (9) from the spindle (10) and separate the spindle from the axle (3).
- Remove the thrust washer (11) and king pin tube (12) from the spindle (10). Wrap a towel around the spindle and let the spindle rest on the ground.
- Repeat the procedure on the passenger side allowing the rack ball joint (29) to rest on the front spring to support the spindle.

WARNING To decrease the risk of possible injury from falling steering components, secure the rack and pinion unit (16) to the front springs with wire.

This will decrease the risk of the intermediate shaft connecting the rack and pinion unit to the steering column from pulling apart due to the weight of the steering system.

NOTICE: The intermediate shaft is assembled with the universal joints set 90° out of phase with each other.

- Remove two hex head bolts (13), spacers (31), washers (30) and lock nuts (15) securing the rack and pinion unit (16) to the front axle. Discard the lock nuts (15). Move the rack and pinion unit back to rest on top of the front springs (17).

- Secure the rack and pinion unit to the spring with wire to decrease the risk of pulling apart the intermediate shaft.
- Remove three bolts (18) and lock nuts (19) from the passenger side leaf spring.
- Remove the spring plate (24). Remove the long bolt (20) and nuts (19, 21), spacer (23) and washers (22, 14). Note the order of the washers and spacer.
- Remove the two remaining bolts (18) and lock nuts (19). Retain the hardware for installation into their original locations.

CAUTION To decrease the risk of stress and possible damage to the rack and pinion unit, the driver side spring must be mounted to the axle with the hardware (20 - 23) installed in its original location (Figure 6).

- To decrease the risk of damage to the bellows (16), the two bolts (18) must be installed in their original location.
- Install the front axle (3) in the reverse order of removal using new lock nuts (15, 19). All hardware (18 - 24) must be installed in its original location (Figure 6).
- Assemble the leaf spring, rack and pinion hardware (13 - 15, 18 - 21) as shown in (Figure 6).

Item	Torque Specification
15, 19	35 - 50 ft. lbs. (47 - 68 Nm)

- Check that the spindle turns freely on the king pin tube after tightening.
- Install thrust washers (11), king pin tubes (12), spindles, washers (9) and bolts (7). Tighten the new lock nuts (6) to the torque value specified below.

Item	Torque Specification
6	56 - 70 ft. lbs. (75 - 95 Nm)

- Tighten the shock absorber mounting hardware until the rubber bushings expand to the diameter of the shock absorber washer.
- Install the front wheels as per the WHEELS AND TIRES section.
- Lower the vehicle per the SAFETY section.
- Check the front wheel alignment and adjust if necessary. Refer to "Wheel Alignment".

FRONT SUSPENSION AND STEERING

Read all of SAFETY and this section before attempting any procedure. Pay particular attention to Notices, Cautions, Warnings and Dangers.

Front Spring Replacement

Tool List	Quantity
Jack Stands.....	4
Ratchet.....	1
Socket, 3/4".....	1
Socket, 5/8".....	1
Wrench, 5/8".....	1
Torque Wrench ft. lbs.	1
Measuring Tape.....	1

NOTICE: Failure of a single spring will result in over stressing the other spring; therefore, replace the front springs as a set.

The following procedure will replace one spring at a time:

- Loosen front wheel lug nuts.
- Lift and support the front of the vehicle per the SAFETY section. Support the front axle with jack stands. Remove the lug nuts and the front wheels.

To detach driver side spring:

- Loosen the two rack and pinion unit lock nuts (15) until only one thread is engaged (Figure 6). Remove the lock nut (15) and washer (14) from the long bolt (20). Discard the lock nut. The rack and pinion unit is now loose.
- Remove the two bolts (18) and lock nuts (19) securing the driver side spring to the axle. Discard the lock nuts (19).
- Hold the nut (21) with a wrench and loosen the long bolt (20). Note the location of the washer (22). Thread the long bolt out as far as possible to remove the washer, nut and spacer (23). Pull the long bolt and the spring plate (24) from the axle and spring. Retain items (20 - 24) for assembly at their original locations.
- Pull the upper driver side of floor mat out of the plastic trim retainer and away from the floor. Locate and remove the hex head bolt (25), spring plate (26) and lock nut (27) securing the rear of the leaf spring (17) to the vehicle frame. Discard the lock nut (27).

CAUTION To decrease the risk of stress and possible damage to the rack and pinion unit, the driver side spring must be mounted to the axle with the hardware (20 - 23) installed in its original location (Figure 6).

- Install the driver side spring in the reverse order of removal. Be sure to install the long bolt (20), spring plate (24), spacer (23), nut (21) and washer (22) in their original locations. Use new lock nuts (15, 19, 27) to secure the rack and pinion unit (16), two short bolts (18) and rear bolts (25).

To detach passenger side spring:

- Remove the hardware (18, 19, 24) securing the front of the passenger side leaf spring (17) to the axle (3). Discard the lock nuts (19) (Figure 6).
- Pull the upper passenger side of the floor mat out of the plastic trim retainer and away from the floor. Locate and remove hardware (25 - 27) securing the rear of the leaf spring (17) to the vehicle frame. Discard the lock nuts (27).
- Install the passenger side spring in the reverse order of removal using new lock nuts (19, 27).

NOTICE: After the springs are replaced, the axle will need to be aligned to the frame. Unless the axle has been replaced, wheel alignment will not be affected; however, it is always good practice to check the wheel alignment any time the front-end components are replaced or adjusted.

- When the front springs are replaced, the front axle must be aligned to the frame. The distance from the center bolt at the rear of the left spring to the center bolt at the front of the right spring must be the same as the distance from the center bolt at the rear of the right spring to the center bolt at the front of the left spring (Figure 7). Tighten the spring hardware (21, 19, 27) first, and the rack and pinion unit hardware (15) second, to the torque value specified below (Figure 6).

Item	Torque Specification
21, 27	35 - 50 ft. lbs. (47 - 68 Nm)

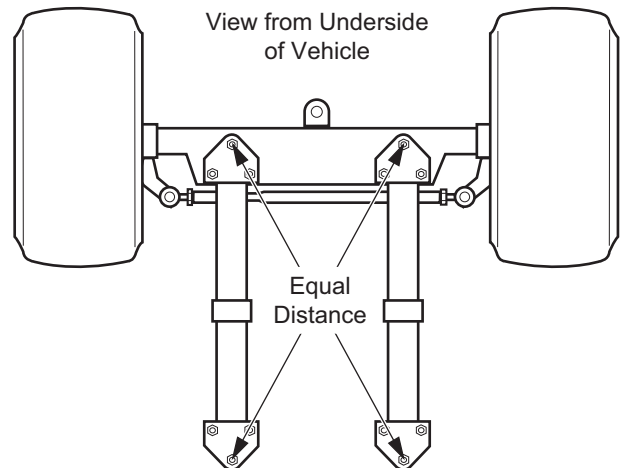

Figure 7 Front Axle Alignment

- Replace the upper portion of the floor mat in the plastic trim retainers. Install the front wheels per the WHEELS AND TIRES section.
- Lower vehicle per the SAFETY section.
- Check the front wheel alignment and adjust if necessary. Refer to "Wheel Alignment".

FRONT SUSPENSION AND STEERING

Read all of SAFETY and this section before attempting any procedure. Pay particular attention to Notices, Cautions, Warnings and Dangers.

Hub Replacement

Tool List	Quantity
Socket, 3/4"	1
Ratchet	1
Straight Blade Screwdriver	1
Ball Peen Hammer	1
Needle Nose Pliers	1
Socket, 1 1/2"	1
Wheel Bearing Grease	AR
Seal Driver	1

- Loosen the front wheel lug nuts.
- Lift and support the front of the vehicle as instructed in the SAFETY section.
- Remove lug nuts and front wheels.
- Remove the dust cap (1), cotter pin (2) and castellated nut (3) (Figure 8). While holding the outer wheel bearing (4) in place, slide the hub (5) from the spindle (6) and discard (Figure 8).
- Clean the spindle and the new hub thoroughly with solvent.
- Pack the new bearings with grease. Refer to "Wheel Bearing Packing".
- Apply a light coat of grease to the inner race. Place the inner wheel bearing (7) into the hub. Orient the new grease seal (8) so the flange side of the seal is facing into the bore. Tap gently into place until the seal is flush with the end of the hub. Lubricate the lips of the seal and spindle with grease (Figure 9).
- Place the new hub onto the spindle and fill the area between the two wheel bearings 1/2 - 3/4 full with grease. Apply a light coating of grease to the outer bearing race.
- Install the outer wheel bearing (4) and secure the hub loosely with the castellated nut. Place the wheel onto the hub and hand tighten the lug nuts.

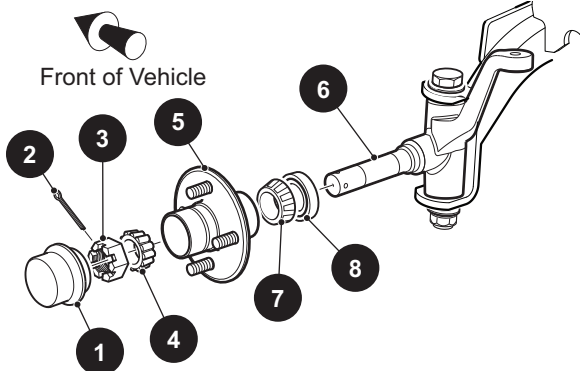

Figure 8 Hub Replacement

- Adjust the bearing. Refer to "Wheel Bearing Adjustment".
- Replace the dust cap (1).

- Lower the vehicle per the SAFETY section.
- Tighten the front wheel(s) per the WHEELS and TIRES section.

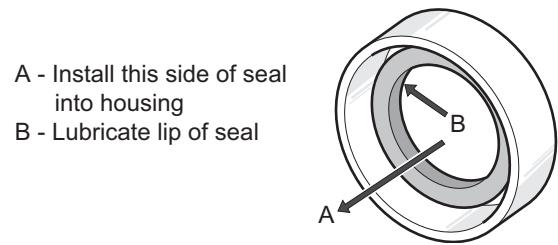

Figure 9 Seal Installation

Wheel Bearing and Race Replacement

Tool List	Quantity
Non-Ferrous Punch.....	1
Ball Peen Hammer.....	1
Bearing Driver.....	1

- Remove the hub (1) from the spindle (2) (Figure 10). See Hub Replacement.
- Remove the grease seal (3), inner wheel bearing (4) and bearing races (5) by tapping, through the other side of hub, the bearing race using a hammer and a soft nonferrous punch. Tap the race in a circular pattern while moving from side to side to avoid damaging the bore of hub.
- Clean the outer wheel bearing (5), inner wheel bearing (4), hub and dust cap (6) in solvent and dry thoroughly. Inspect for signs of damage. If pitting or blue coloration is present in the rollers, the bearing must be replaced. If the roller portion of the bearing is to be replaced, the race must also be replaced.
- To install the race (5), make sure the bore of the hub (1) is clean. Place the new race over the bore of the hub. Tap evenly with a hammer and bearing driver to drive the race fully into the bore. Repeat on the other side of the hub.
- Clean the spindle (2) and pack the new bearings with grease. See Wheel Bearing Packing..

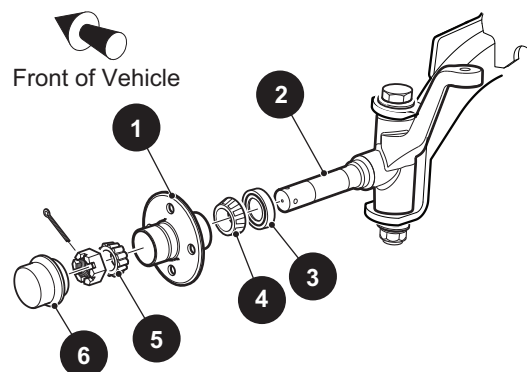

Figure 10 Wheel Bearing Replacement

FRONT SUSPENSION AND STEERING

Read all of SAFETY and this section before attempting any procedure. Pay particular attention to Notices, Cautions, Warnings and Dangers.

6. Install the inner wheel bearing (4) and new grease seal in the hub. Mount the hub to the spindle. See Hub Replacement. To adjust the wheel bearing, refer to "Wheel Bearing Adjustment".
7. Replace the dust cap (6).
8. Lower the vehicle per the SAFETY section.
9. Tighten the front wheel lug nuts per the WHEELS AND TIRES section.

STEERING

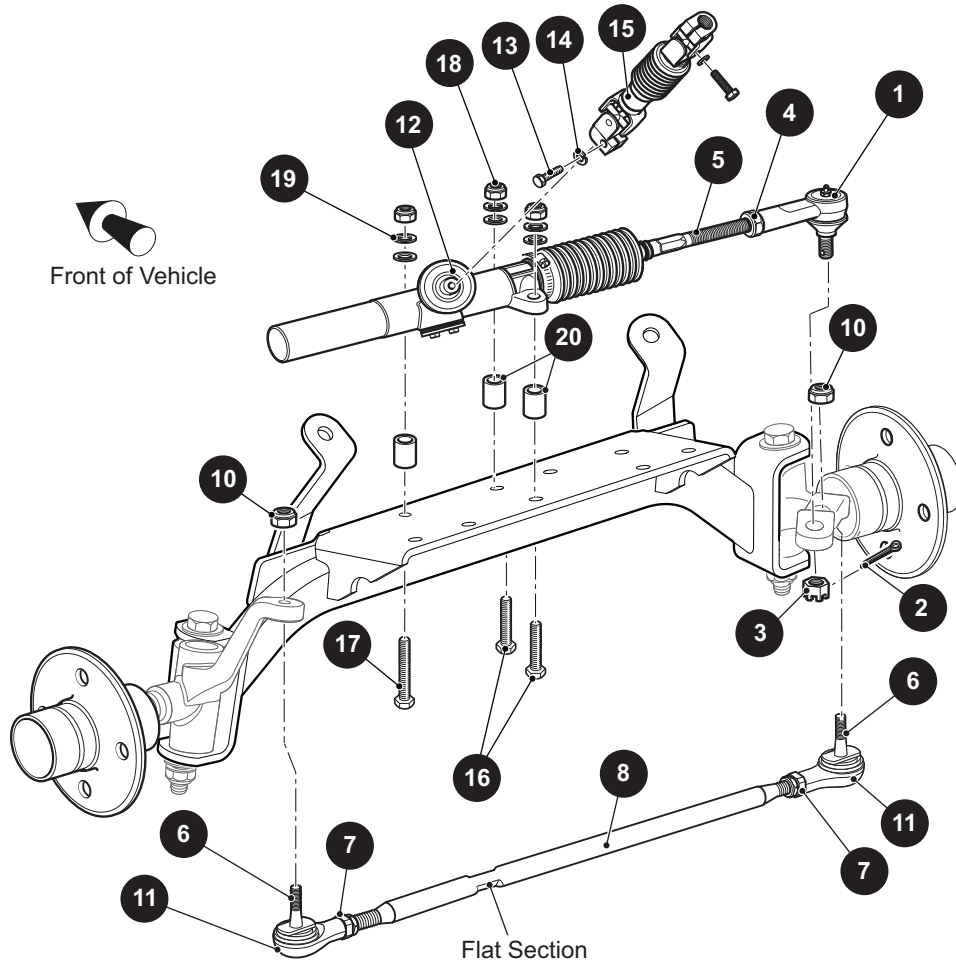

Figure 11 Steering Components

Rack Ball Joint Replacement

Tool List

	Quantity
Needle Nose Pliers.....	1
Wrench, 11/16"	1
Ball Joint Separator	1
Plastic Faced Hammer	1
Measuring Tape	1
Wrench, 3/4"	1
Torque Wrench, ft. lbs	1
Socket, 11/16"	1

1. To remove the rack ball joint (1), loosen the lug nuts on the passenger side front wheel.
2. Lift and support the front of the vehicle per the SAFETY section (Figure 11).
3. Remove the passenger side front wheel. Turn the steering wheel fully to the left.
4. Remove the cotter pin (2) and loosen the castellated nut (3) until the rack ball joint (1) threads are protected. Using a ball joint separator as a lever, apply pressure to the ball joint and tap the nut with a plastic faced hammer to release the ball joint from the spindle arm. Remove the nut from the ball joint and remove the ball joint from the spindle arm.

FRONT SUSPENSION AND STEERING

Read all of SAFETY and this section before attempting any procedure. Pay particular attention to Notices, Cautions, Warnings and Dangers.

- To install the new rack ball joint close to its correct position, measure amount of threads exposed from jam nut (Figure 12).

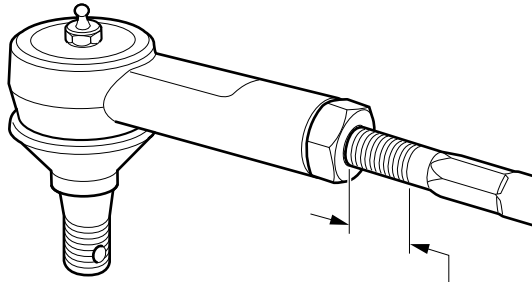

Measure exposed thread length.
Use measured length to position new ball joint at same location.

Figure 12 Rack Ball Joint Installation

- Loosen the jam nut (4) and remove the ball joint from the rack extension (5) (Figure 11).
- Using the measurement made earlier, thread the jam nut and new ball joint (1) onto the rack extension. Set the jam nut (4) finger tight against the ball joint (Figure 12).
- Attach the ball joint (1) to the spindle arm. Tighten the castellated nut (3) to the torque value specified below. Check to see if a cotter pin (2) can be inserted through the ball joint stud, if the hole does not line up with the slots in the nut, continue to tighten until a new cotter pin (2) can be installed through the nut and stud (Figure 11).

Item	Torque Specification
3	36 - 50 ft. lbs. (49 - 68 Nm)

CAUTION After replacing or servicing the steering components, verify that a 1/8" gap exists between the large hex of the rack extension and the rack and pinion unit when the steering wheel is turned fully to the right (Figure 20).

- Check for proper rack extension-to-rack and pinion unit clearance before tightening the jam nut (4) to the torque value specified below.

Item	Torque Specification
4	35 - 50 ft. lbs. (47 - 68 Nm)

- Refer to "Checking/Adjusting Rack Extension-to-Rack and Pinion Unit Clearance".

- Install the passenger side front wheel per the WHEELS AND TIRES section.
- Lower vehicle per the SAFETY section.
- Check the front wheel alignment and adjust if necessary. Refer to "Wheel Alignment".

Tie Rod Inspection/Replacement

Tool List	Quantity
Measuring Tape	1
Wrench, 3/4"	1
Wrench, 9/16"	1
Needle Nose Pliers	1
Wrench, 11/16"	1
Ball Joint Separator.....	1
Plastic Faced Hammer.....	1
Socket, 11/16"	1
Torque Wrench, ft. lbs.	1
Crowfoot Socket, 3/4"	1

Grasp the tie rod (8) at the ball joints (6) and check for any vertical motion which would indicate a worn condition and require replacement (Figure 11).

- To remove the tie rod, loosen the front wheel lug nuts.
- Lift and support front of the vehicle per the SAFETY section.
- Remove the lug nuts and the front wheel.
- Measure the exposed thread length at the jam nuts (7). Use this dimension to position the rod ends on the new tie rod.

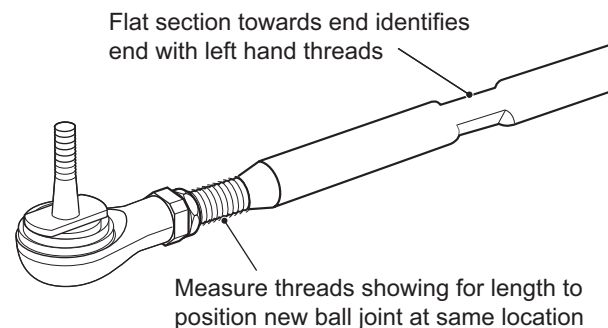

Flat section towards end identifies end with left hand threads

Measure threads showing for length to position new ball joint at same location

Figure 13 Tie Rod Replacement

NOTICE: The tie rod has different threads on each end. The end with the flat area on the threaded tube has left hand threads (clockwise to loosen) while the end without the flat has conventional right hand threads (counter-clockwise to loosen) (Figure 13).

- Loosen the lock nut (10) until the tie rod ball joint (6) threads are protected. Using a ball joint separator as a lever, apply pressure to the ball joint and tap the nut with a plastic faced hammer to release the tie rod

FRONT SUSPENSION AND STEERING

Read all of SAFETY and this section before attempting any procedure. Pay particular attention to Notices, Cautions, Warnings and Dangers.

- from the spindle arm. Remove the nut (10) to drop the tie rod from the spindle arm.
- Remove the ball joint (6) from the tie rod.
- Thread on the new jam nut. Using the measurement made earlier, screw the ball joint to the previous location on the tie rod. Set the jam nut hand tight.

NOTICE: Use the measurement taken earlier to position the rod end on the tie rod.

- Install the rod end in the spindle and secure with a locking nut (10). Tighten the lock nut (10) to the torque value specified below.

Item	Torque Specification
10	36 - 50 ft. lbs. (47 - 68 Nm)

- Install the front wheel(s) per the WHEELS AND TIRES section.
- Lower the vehicle per the SAFETY section.
- A worn tie rod is likely to have caused incorrect wheel alignment. Check the front wheel alignment and adjust if necessary. Refer to "Wheel Alignment".
- Tighten the jam nut (7) to the torque value specified below.

Item	Torque Specification
7	36 - 50 ft. lbs. (49 - 68 Nm)

Bellows Replacement

Tool List	Quantity
Needle Nose Pliers.....	1
Wrench, 11/16".....	1
Ball Joint Separator.....	1
Plastic Faced Hammer.....	1
Measuring Tape.....	1
Wrench, 3/4".....	1
Wire Cutters.....	1
Wire Tie, 8" Long.....	1
Torque Wrench, ft. lbs.....	1
Socket, 11/16".....	1

- To replace the bellows (1) (Figure 14), loosen the passenger side front wheel lug nuts.
- Lift and support the front of the vehicle per the SAFETY section.
- Remove the passenger side front lug nuts. Turn the steering wheel fully to the left.
- Remove the rack ball joint (2) and jam nut (3) from the rack extension (4). See Rack Ball Joint Replacement.

- Cut the wire ties (5, 6) and slide the bellows off of the rack extension. Install the new bellows. Align the small end of the bellows over the groove in the rack extension. Secure with a new wire tie (5). Leave the large end of the bellows loose until the rack extension-to-rack and pinion unit clearance is checked or adjusted.
- Install the jam nut (3) and ball joint (2) on the rack extension (4). Connect the ball joint to the spindle arm. See Rack Ball Joint Replacement.

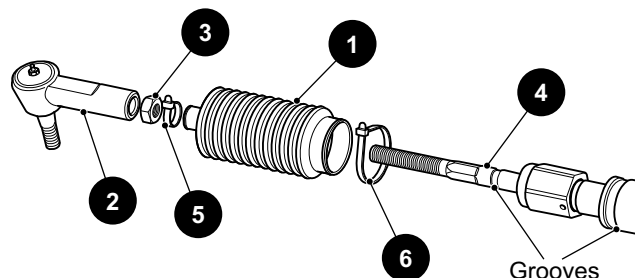

Figure 14 Bellows Replacement

CAUTION After replacing or servicing the steering components, verify that a 1/8" gap exists between the large hex of the rack extension and the rack and pinion unit when the steering is turned fully to the right.

- Check for proper rack extension-to-rack and pinion unit clearance before tightening the jam nut (3) to the torque value specified below.

Item	Torque Specification
3	35 - 45 ft. lbs. (47 - 61 Nm)

- Secure the bellows (1) to the rack extension (4) with the new wire ties (5, 6).
- Refer to "Checking/Adjusting Rack Extension-to-Rack and Pinion Unit Clearance".
- Install the passenger side front wheel per the WHEELS AND TIRES section. Lower vehicle per SAFETY section.
- Check the front wheel alignment and adjust if necessary. See Wheel Alignment.

Pinion Seal Replacement

Tool List	Quantity
Vice.....	1
Straight Blade Screwdriver, Small.....	1
Ball Peen Hammer.....	1
Sandpaper, 600 Grit.....	AR
Shop Towel.....	AR
Wheel Bearing Grease.....	AR

FRONT SUSPENSION AND STEERING

Read all of SAFETY and this section before attempting any procedure. Pay particular attention to Notices, Cautions, Warnings and Dangers.

Socket, 1 1/2" 1

CAUTION To avoid damage to the aluminum rack and pinion unit, secure the unit in a vice by the mounting ears only.

- To access the pinion seal, remove the rack and pinion unit from the vehicle. See Rack and Pinion Unit Replacement. Anchor the unit in a vice by clamping on the mounting ears of the rack and pinion unit.
- Slide a small straight blade screwdriver between the lip of the seal and pinion and pry the top portion of the seal up to remove (Figure 15).

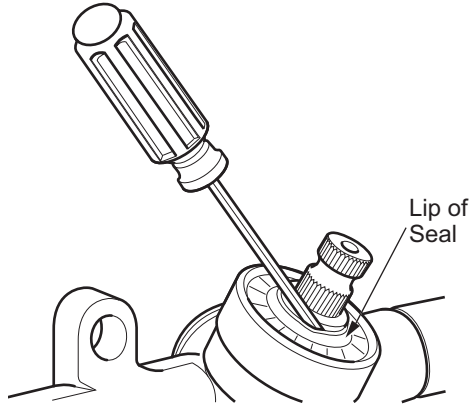

Figure 15 Pinion Seal Replacement

- Use the screwdriver to lift the inner portion of the seal up and off the pinion.
- Check the pinion surface for roughness. Sand lightly if needed.

NOTICE: Wipe the bore clean and lubricate the pinion and lip of the seal with grease. The bore has a positive stop to correctly locate the seal during installation.

- Place the seal over the pinion and tap carefully with a socket and hammer to start the seal straight into the bore. Drive the seal fully into the bore until it stops. Wipe clean any excess grease.
- Attach the rack and pinion unit to the front axle. See Rack and Pinion Unit Replacement.

Spindle Replacement

Tool List	Quantity
Needle Nose Pliers	1
Wrench, 11/16"	1
Ball Joint Separator	1
Plastic Faced Hammer	1
Wrench, 3/4"	1
Socket, 3/4"	1
Socket, 11/16"	1
Torque Wrench, ft. lbs.	1

CAUTION The spindle bearings are designed to be used "dry". Lubrication attracts dirt and will damage the bearings. Do not apply grease to the spindle bearings.

- Loosen the front wheel lug nuts.
- Lift and support the front of the vehicle per the SAFETY section.
- Remove the front wheel lug nuts and the wheel.
- To remove the tie rod, loosen the lock nut (2) until the tie rod ball joint (3) threads are protected (Figure 16). Using a ball joint separator as a lever, apply pressure to the ball joint and tap the nut with a plastic faced hammer to release the tie rod from the spindle arm (4). Remove the nut from the tie rod and tie rod from the spindle arm.
- Remove lock nut (5) and washer (7) from the bolt (6). Discard the nut (5). Pull bolt (6) and washer (8) from the spindle and separate the spindle from the axle. Remove the thrust washer (9) and the king pin tube (10) from the spindle.
- Install the spindle in the reverse order of removal.

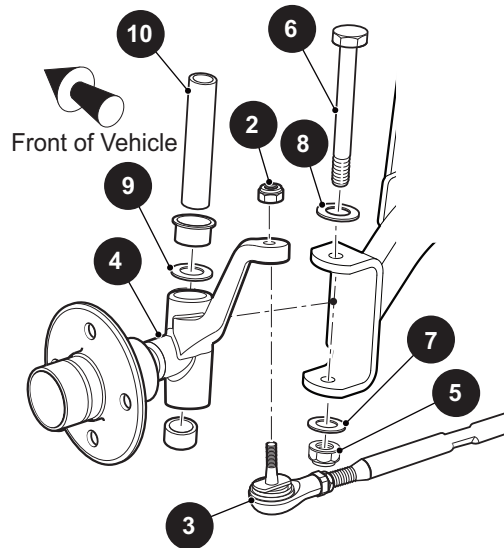

Figure 16 Spindle Replacement

NOTICE: The thrust washer (9) is located on top of the spindle between the spindle and the front axle.

- Tighten the new lock nuts (2, 5) to the torque values specified below. Check that the spindle turns freely on the king pin tube after tightening.

Item	Torque Specification
2	35 - 50 ft. lbs. (47 - 68 Nm)
5	56 - 70 ft. lbs. (76 - 95 Nm)

FRONT SUSPENSION AND STEERING

Read all of SAFETY and this section before attempting any procedure. Pay particular attention to Notices, Cautions, Warnings and Dangers.

8. Install the front wheels per the WHEELS AND TIRES section.
9. Lower the vehicle per the SAFETY section.
10. Check the front wheel alignment and adjust if necessary. See Rack and Pinion Unit Replacement.

Rack and Pinion Unit Disassembly and Inspection

Tool List	Quantity
Vice	1
Socket, 3/8"	1
Ratchet	1
Wrench, 11/16"	1
Wrench, 3/4"	1
Wire Cutter	1
Retaining Ring Pliers	1
Shop Towel	AR
CITGO Lithoplex MP No. 2 grease	AR
Wire Tie, 8" Long	1
Wire Tie, 10" Long	1
Torque Wrench, in. lbs.	1

NOTICE: The rack and pinion gears are not serviceable items. If they are found to be damaged or excessively worn, a new rack and pinion unit must be installed.

CAUTION To avoid damage to the aluminum rack and pinion unit, secure the unit in a vice by the mounting ears only.

1. Remove the rack and pinion unit from the vehicle. Anchor the unit in a vice by clamping on the mounting ears of the unit.
2. Disassemble the rack and pinion unit (1) by removing the screw (13) and the tensioner (2) to relieve pressure on the rack (3) and pinion (4) (Figure 17).
3. Loosen the jam nut (5) and remove the rack ball joint (6) from the rack extension (7).
4. Cut the wire ties (8, 14) securing the bellows (9). Slide the bellows off of the rack extension. Pull the rack (3) from the unit (1).
5. Remove the pinion seal (10). See Pinion Seal Replacement.
6. Remove the internal retaining ring (11) from the rack and pinion unit. Pull out the pinion (4) and ball bearing (12) as an assembly.

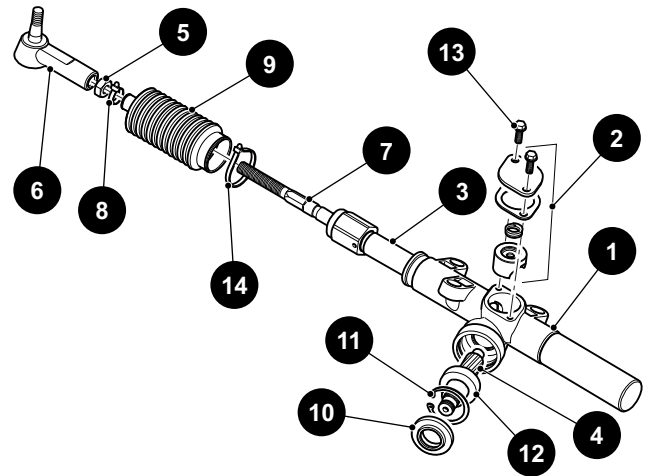

Figure 17 Rack and Pinion Unit Disassembly

7. Clean the rack, pinion and housing. Inspect the gear teeth, bearing surfaces and grease seal surfaces of the unit for excessive wear or damage. If any damage or excessive wear is found, the rack and pinion unit **must be** replaced as an assembly. See Rack and Pinion Unit Replacement.
8. If the rack and pinion unit is still serviceable, clean the components thoroughly and lubricate with CITGO Lithoplex MP No. 2 grease.
9. Assemble the rack and pinion unit by installing the pinion in the reverse order of removal. Make sure to lubricate the pinion seal lip prior to installing the seal. See Pinion Seal Replacement.
10. Insert the rack into the rack and pinion unit. Turn the pinion clockwise to help pull rack in if necessary. Install bellows and secure to the rack extension with a wire tie (8).
11. **Do not** secure the large end of the bellows to the rack and pinion unit until after setting the proper rack extension-to-rack and pinion unit clearance. Install the tensioner and tighten the bolts (13) to the torque value specified below.

Item	Torque Specification
13	100 - 120 in. lbs. (11 - 14 Nm)

12. Thread the jam nut and the rack ball joint to the original location on the rack extension. Set the jam nut hand tight.
13. Secure the bellows (1) to the rack extension (4) with the new wire ties (8, 14)
14. Install the rack and pinion unit on the vehicle. See Rack and Pinion Unit Replacement.

FRONT SUSPENSION AND STEERING

Read all of SAFETY and this section before attempting any procedure. Pay particular attention to Notices, Cautions, Warnings and Dangers.

CAUTION After replacing or servicing steering components, always verify that a 1/8" gap exists between the large hex of the rack extension and the rack and pinion unit when the steering wheel is turned fully to the right, forcing the passenger spindle arm against the front axle.

- Set the proper rack extension-to-rack and pinion unit clearance. See Checking/Adjusting Rack Extension-to-Rack and Pinion Unit Clearance.

Rack and Pinion Unit Replacement

Tool List	Quantity
Socket, 13 mm.....	1
Ratchet.....	1
Needle Nose Pliers.....	1
Wrench, 11/16".....	1
Ball Joint Separator.....	1
Plastic Faced Hammer.....	1
Wrench, 5/8".....	1
Socket, 5/8".....	1
Ratchet.....	1
Torque Wrench, ft. lbs.....	1
Socket, 11/16".....	1
Torque Wrench, in. lbs.....	1

- To remove the rack and pinion unit (12) (Figure 11), loosen the front wheel lug nuts.
- Lift and support the front of the vehicle per the SAFETY section.
- Remove front wheels lug nuts and the front wheels.
- Remove the bolt (13) and washer (14) securing the intermediate shaft (15) to the rack and pinion unit (12).
- Remove the cotter pin (2) and loosen castellated nut (3) until rack ball joint (1) threads are protected. Using a ball joint separator as a lever, apply pressure to the ball joint and tap the nut with a plastic faced hammer to release the ball joint from the passenger side spindle arm. Remove the nut from the ball joint and the ball joint from the spindle arm.
- Remove the three lock nuts (18) securing the rack and pinion unit to the front axle. Discard the nuts. The rack and pinion unit can now be removed from the vehicle. Retain the washers (19), spacers (20) and the two bolts (16) for assembly.
- Replace the rack and pinion unit in the reverse order of removal.
- Use new lock nuts (18) and tighten them to the specified value torque.

- Tighten the castellated nut (3) to the torque value specified below. Tighten as needed to insert a new cotter pin.

Item	Torque Specification
18	35 - 50 ft. lbs. (47 - 68 Nm)

- Tighten the bolt (13) securing the intermediate shaft to the pinion to the torque value specified below.

Item	Torque Specification
3	36 - 50 ft. lbs. (49 - 68 Nm)
13	13 - 18 ft. lbs. (18 - 24 Nm)

CAUTION After replacing or servicing the steering components, always verify that a 1/8" gap exists between the large hex of the rack extension and the rack and pinion unit when the steering wheel is turned fully to the right, forcing the passenger spindle arm against the front axle.

- Set the proper rack extension-to-rack and pinion unit clearance. Refer to "Checking/Adjusting Rack Extension-to-Rack and Pinion Unit Clearance".
- Install the passenger side front wheel per the WHEELS AND TIRES section.
- Lower the vehicle per the SAFETY section.
- Check the front wheel alignment and adjust if necessary. Refer to "Wheel Alignment".

Checking/Adjusting Rack Extension-to-Rack and Pinion Unit Clearance

Tool List	Quantity
Wrench, 11/16".....	1
Wrench, 3/4".....	1
Wrench, 1/2".....	1
Wire Cutter.....	1
Washer, 1/8" Thick.....	1
Crowfoot Socket, 3/4".....	1
Torque Wrench, ft. lbs.....	1
Wire Tie, 10" long.....	1

- Check for proper rack extension-to-rack and pinion unit clearance by first turning the steering wheel fully to the right.
- The rear spindle arm on the passenger side **must rest against** the front axle (Figure 18). If it does not, all adjustment is made at the rack ball joint (6) (Figure 17).
- Loosen the jam nut (5) at the rack ball joint and use a wrench to thread the shaft of the rack extension (7)

FRONT SUSPENSION AND STEERING

Read all of SAFETY and this section before attempting any procedure. Pay particular attention to Notices, Cautions, Warnings and Dangers.

further into the rack ball-joint. This will provide more travel for the steering wheel to be turned to the right.

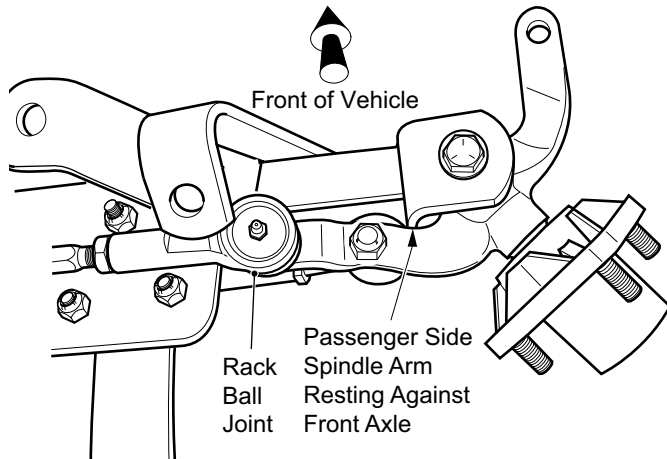

Figure 18 Spindle Contact with Front Axle

- With the spindle arm resting against the front axle, cut the wire tie (14) securing the bellows (9) to the rack and pinion unit (1). Slide the bellows away from the rack and pinion unit to see the large hex of the rack extension. A 1/8" gap should exist between the large hex and the end of the rack and pinion unit.

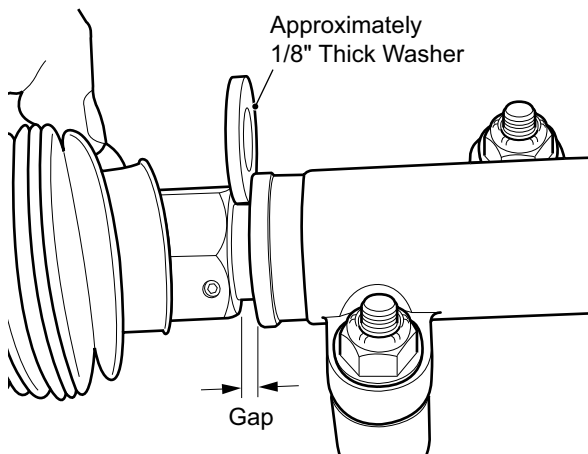

Figure 19 Checking Gap

- Adjust, using a 1/8" thick washer as a gauge, by turning the shaft of the rack extension with a wrench to create the 1/8" gap.
- Tighten the jam nut (5) to the torque value specified below.

Item	Torque Specification
5	35 - 45 ft. lbs. (47 - 61 Nm)

- Secure the bellows to the rack and pinion unit with a new wire tie (14).

Steering Wheel Replacement

Tool List	Quantity
Socket, 15/16"	1
Ratchet	1
Plastic Faced Hammer	1
Ball Peen Hammer	1
Anti-seize Compound	1
Torque Wrench, ft. lbs.	1

NOTICE: To maintain the correct orientation when replacing the steering wheel, turn the wheels straight ahead.

CAUTION To decrease the risk of damage to the clipboard, perform the following removal procedure. Do not use a screwdriver to push or pry the retaining tabs.

- From the front side of the steering wheel (4), remove the steering wheel cover by pulling straight up on the bottom of the steering wheel cover to release the two bottom retaining tabs. Using thumb for leverage as shown, reach from behind the steering wheel with fingertips to first pull down, and then push up to release the two top clipboard retaining tabs (Figure 20).

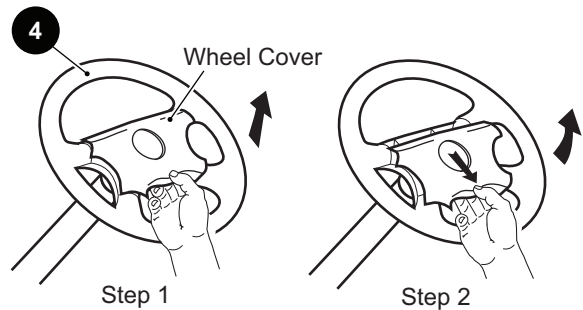

Figure 20 Clipboard Removal

- Loosen the steering wheel retaining nut (6) two to three turns (Figure 21). **Do not remove the nut at this time.**
- Apply upward pressure to the steering wheel. Place a plastic faced hammer against the steering wheel nut and strike the plastic faced hammer sharply with a ball peen hammer.

FRONT SUSPENSION AND STEERING

Read all of SAFETY and this section before attempting any procedure. Pay particular attention to Notices, Cautions, Warnings and Dangers.

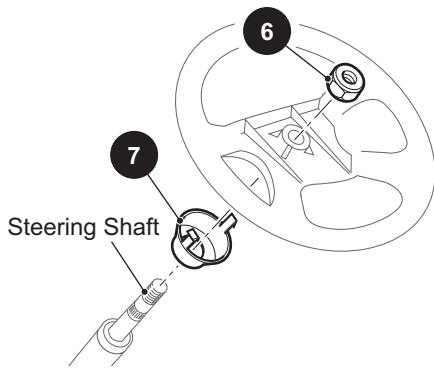

Figure 21 Steering Wheel Replacement

CAUTION Do not strike steering the nut or the end of the steering shaft directly with a ball peen hammer. Internal damage to the rack and pinion unit can result.

4. When the steering wheel is loosened, remove the retaining nut and remove the steering wheel.
5. Prior to replacement, assemble the replacement steering wheel by aligning the retaining tabs on the rear collar hub (7) with the slots in the back of the steering wheel. Squeeze the tabs to allow insertion of the hub. **Do not force.** Squeeze the hub on the top and the bottom to fully seat.
6. Replace the steering wheel by lightly coating the splines of the steering shaft with anti-seize compound. With the vehicle wheels in the straight ahead position, align the steering wheel on the steering shaft and slide the wheel onto the shaft.
7. Tighten the steering wheel nut (6) to the torque value specified below.

Item	Torque Specification
6	15 - 20 ft. lbs. (20 - 27 Nm)

8. Inspect the four retaining tabs on the clipboard (5) for white stress lines (Figure 20). If stress lines are present, replace clipboard. Install by carefully pressing the top two, and the bottom two retaining tabs into the matching slots in the steering wheel.

Steering Shaft and Column Replacement

Tool List

	Quantity
Ratchet.....	1
Socket, 3/4".....	1
Socket, 13 mm.....	1
Ratchet.....	1
Socket, 9/16".....	1
O-ring Pliers.....	1

Bearing Separator.....	1
Gear Puller.....	1
Arbor Press.....	1
Bearing Driver Set.....	1
Torque Wrench, ft. lbs.	1
Wheel Bearing Grease.....	AR

1. To remove the steering shaft (4) (Figure 22), remove the steering wheel.
2. Loosen the front wheel lug nuts.
3. Lift and support the front of the vehicle per the SAFETY section.
4. Remove front wheel lug nuts and the front wheels.
5. Remove the bolt (1) and washer (2) that secure the intermediate shaft (3) to the steering shaft (4).
6. Remove the four bolts (5) and washers (6) that secure the steering column (7) to the chassis. Remove the column.
7. Remove the large retaining ring (8) on the bottom end of the column. Pull the shaft and bearing (9) out of the column as an assembly. Slide the wave washer (10) out the bottom end of the steering column.
8. Remove the small retaining ring (11) and press the bearing from the steering shaft.
9. To assemble the steering shaft, press the new bearing onto the shaft until it stops against the shoulder. With the small retaining ring oriented with the arch up, slide the ring onto the shaft as far as possible using o-ring pliers (Figure 23). Use fingers to push the retaining ring fully into the groove.

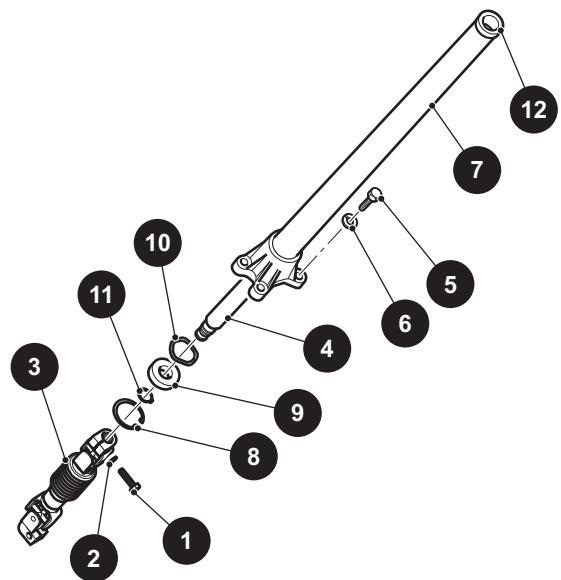

Figure 22 Steering Shaft and Column

10. Slide the wave washer into the base of the steering column.

FRONT SUSPENSION AND STEERING

Read all of SAFETY and this section before attempting any procedure. Pay particular attention to Notices, Cautions, Warnings and Dangers.

11. Apply wheel bearing grease to the lip of the seal in the bushing (12) at the top of the column. Press the steering shaft and bearing assembly into the column base.
12. Secure with a large retaining ring, making sure it is fully seated in the groove of the column.
13. Using four bolts (5) and four washers (6), secure the steering column to the vehicle. Tighten the column bolts (5) to the specified torque value.
14. Using bolt (1) and washer (2), secure the intermediate shaft (3) to the steering shaft. Tighten the bolt (1) to the torque value specified below.

Item	Torque Specification
1	13 - 18 ft. lbs. (18 - 24 Nm)
5	25 - 35 ft. lbs. (34 - 47Nm)

15. Install the front wheel(s) per the WHEELS AND TIRES section.
16. Lower the vehicle per the SAFETY section.
17. Install the steering wheel. Refer to "Steering Wheel Replacement".

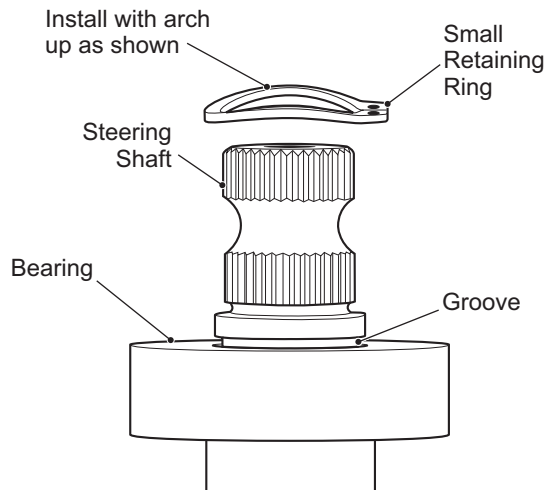
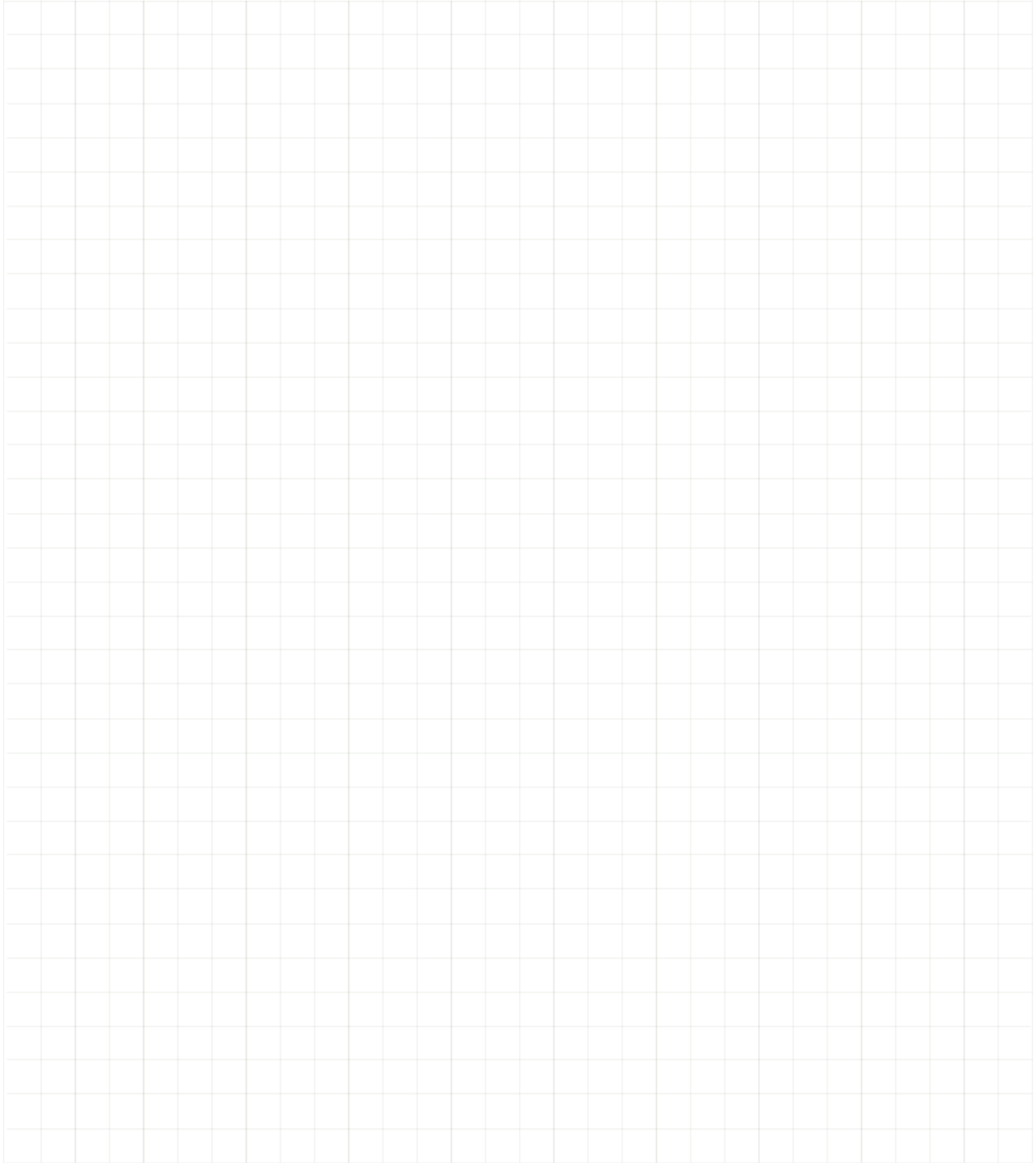

Figure 23 Small Retaining Ring Orientation

FRONT SUSPENSION AND STEERING

Read all of SAFETY and this section before attempting any procedure. Pay particular attention to Notices, Cautions, Warnings and Dangers.

Notes:

A large grid of graph paper for taking notes, consisting of 20 columns and 30 rows of small squares.

REAR AXLE

For further axle information, see the Four Cycle Trans-axle Shop Rebuild and Service Parts Manual.

See REAR SUSPENSION section for axle removal.

NEUTRAL LOCK

To decrease the risk of the secondary clutch from turning the rear wheels during service operations and to decrease the risk of wear to the belt while being towed, a neutral lock is located on the direction selector.

To operate the neutral lock (Ref. Fig. 1):

1. Turn the key switch to the OFF position.
2. Place the direction selector in R (reverse position).
3. Remove the seat.
4. Pull out (1) and rotate (2) the neutral lock pin handle so that the pointed portion of the handle is to the side of the direction selector cam.
5. Move the direction selector lever towards the area between F (forward) and R (reverse). During that motion, the pin will snap into the hole in the direction selector mounting bracket, preventing any movement of the lever. When in this position, the direction selector remains locked in the neutral position.

⚠ WARNING *The neutral lock is a spring loaded mechanism. To decrease the risk of possibility of fingers becoming pinched in the direction selector mechanism, hold the direction selector lever when releasing neutral lock pin handle.*

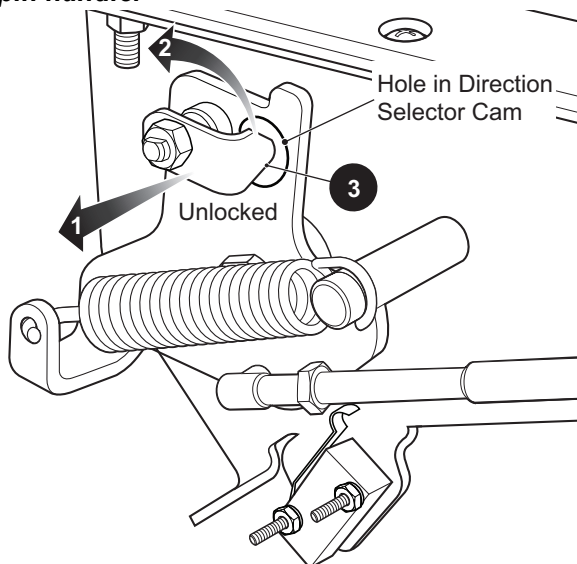

Fig. 1 Neutral Lock (Direction Selector)

Activate the direction selector by pulling the neutral lock pin handle out and rotate until the pointed portion of the

handle fits into the hole (3) in the direction selector cam.

Checking the Lubricant Level

Tool List	Qty.
Socket, 13 mm.....	1
Ratchet	1
Funnel.....	1

NOTICE: *For vehicles with LSD axle, add 2 ounces of friction modifier during refill.*

The rear axle is provided with a lubricant level check plug located on the driver side at the rear of the housing (Ref. Fig. 2). Unless leakage of rear axle lubricant is evident, an annual lubricant check is sufficient.

1. Clean the area around the check and fill plugs.
2. Remove the check plug. The correct lubricant level is **just** below the bottom of the threaded hole.
3. If lubricant is to be added, remove the fill plug and add lubricant using a funnel. Add lubricant slowly until lubricant starts to seep from the check plug hole.
4. Install the check plug and the fill plug.
5. In the event that the lubricant is to be replaced, a drain plug is provided at the bottom of the differential housing. Capacity of axle is 51 ounces (1.5 liters).

Fill / Check Plug

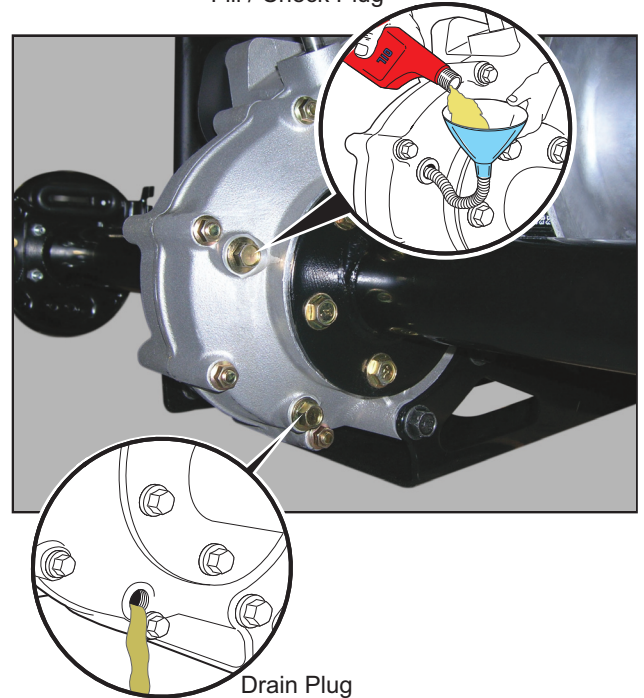

Fig. 2 Add, Check and Drain Rear Axle Lubricant

REAR AXLE

Read all of SAFETY and this section before attempting any procedure. Pay particular attention to Notices, Cautions, Warnings and Dangers.

REAR AXLE DISASSEMBLY

CAUTION The rear axle is a precision assembly, and therefore any repair or replacement of parts must be done with care in a clean environment. Before attempting to perform any service on the axle, read and understand all of the following text and illustrations before disassembling the unit.

Handle all gears with care since each is part of a matched set. Damage to one will require replacement of the entire set.

Snap rings must be removed/installed with care to decrease the risk of damage to the bearings, seals and bearing bores.

NOTICE: It is recommended that when a bearing, seal or o-ring is removed, it must be replaced with a new one regardless of mileage. Always clean the seals and o-rings with a light oil before installing.

WARNING To decrease risk of personal injury or death, follow the lifting procedure in SAFETY section. Place wheel chocks in front and behind the front wheels and check the stability of the vehicle on the jack stands before starting any repair procedure. Never work on a vehicle that is supported by a jack alone.

Axle Shaft Removal and Disassembly

Tool List	Qty.
Arbor Press.....	1
Bearing Separator	1
Needle Nose Pliers.....	1
Internal Snap Ring Pliers.....	1
Slide Hammer, P/N 18753G1	1

For brake drum removal, refer to the BRAKES section.

1. Remove the outer snap ring from the axle tube (Ref. Fig. 3).

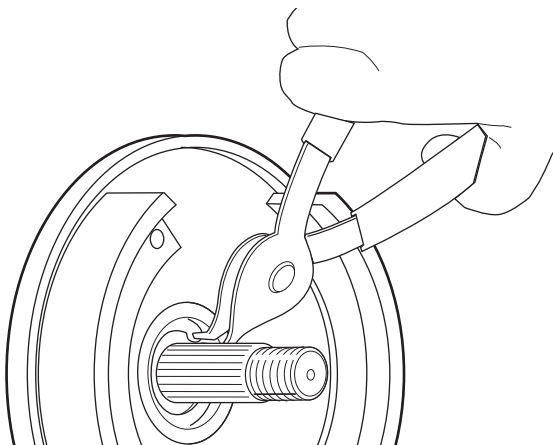

Fig. 3 Removing/Installing Outer Snap Ring

2. Attach a slide hammer to the axle shaft thread and remove the axle and bearing from the axle tube (Ref. Fig. 4).

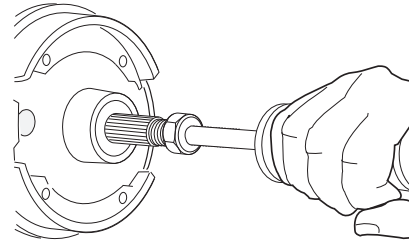

Fig. 4 Removing/Installing Axle Shaft

Remove the bearing by supporting the inner race of the bearing on an arbor press bed and apply pressure to the threaded end of the axle shaft (Ref. Fig. 5).

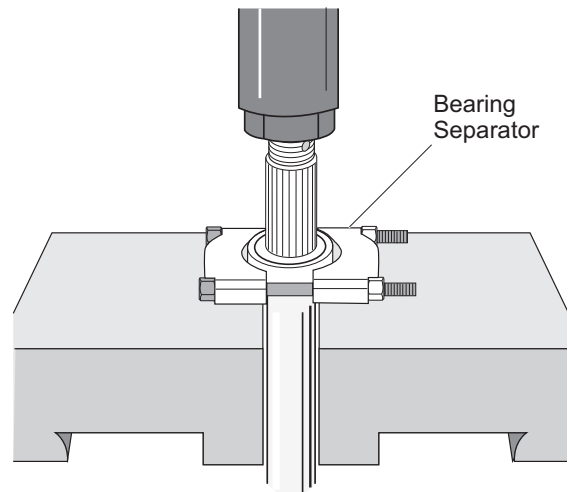

Fig. 5 Pressing Bearing from Axle Shaft

Axle Shaft Seal Removal and Replacement

Tools List	Qty.
Internal Snap Ring Pliers	1
Seal Puller.....	1
Plastic Faced Hammer.....	1
Ratchet.....	1
Torque Wrench, ft. lbs.	1
Socket, 14 mm	1

1. Using snap ring pliers, remove the bearing retaining ring (1) from the end of axle tube (2) (Ref. Fig. 6).
2. Carefully pull the axle shaft (3) and bearing out of the tube.
3. Remove the bolts (4) attaching the axle tube to the casing and carefully lift the tube from the casing studs.
4. Using seal puller, remove the axle shaft seal (5) from the casing.

REAR AXLE

Read all of SAFETY and this section before attempting any procedure. Pay particular attention to Notices, Cautions, Warnings and Dangers.

CAUTION Use care to decrease the risk of damage to the inner surface of axle tube at the sealing area.

- Replace the seal by lightly tapping around the circumference with a plastic faced hammer.

Tighten bolts (4) to the torque value specified below.

Item	Torque Specification
4	26 - 31 ft.lbs. (34 - 42 Nm)

NOTICE: Tighten the castellated axle nut to 70 ft.lbs. (95 Nm) torque minimum. Continue to tighten until the slot in the nut aligns with the cotter pin hole.

- Tighten the axle nut to the torque value specified below.

Item	Torque Specification
Axle Nut	70 ft.lbs. (95 Nm) minimum

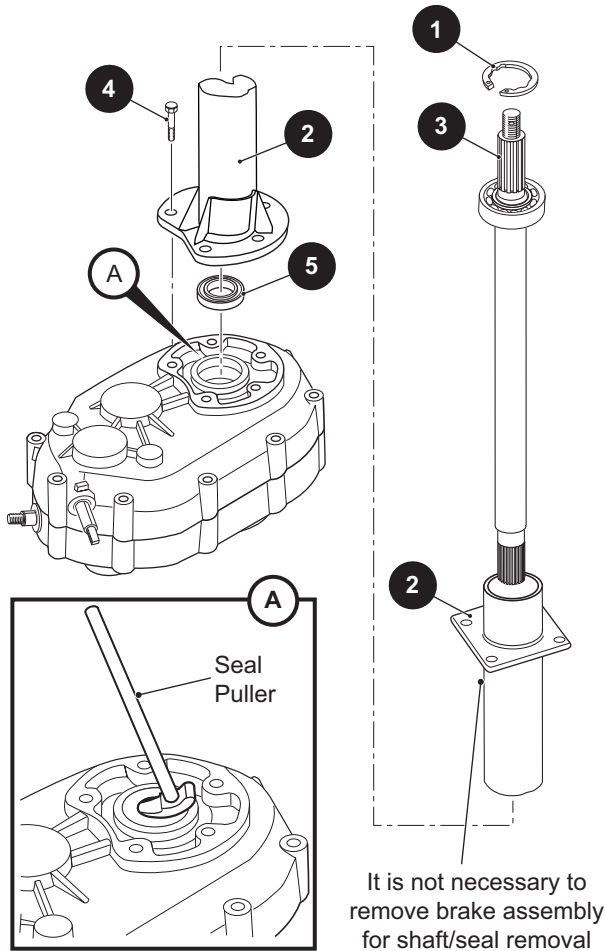

Fig. 6 Removing/Installing Seal

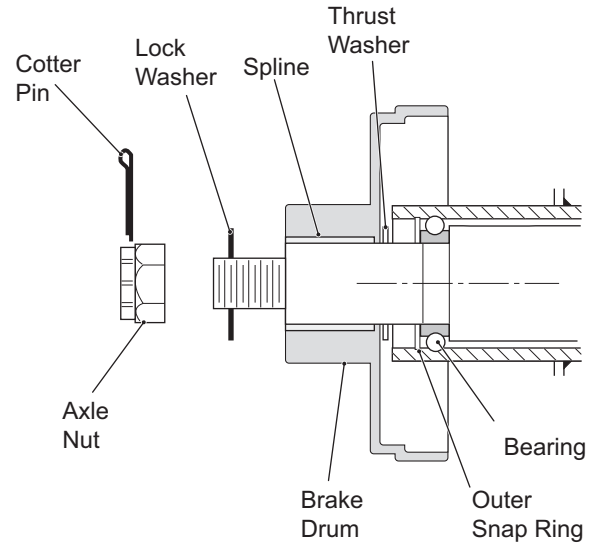

Fig. 7 Cut Away of Outer Bearing and Brake Drum

Axle Shaft Replacement

- Carefully insert the axle shaft and bearing through the oil seal.
- Rotate the shaft until the spline engages with the differential side gears. Install the outer snap ring.
- Coat the outboard spline of the axle with an anti-seize compound. Install the brake hub and drum, thrust washer, nut and new cotter pin (Ref. Fig. 7).

REAR AXLE

Read all of SAFETY and this section before attempting any procedure. Pay particular attention to Notices, Cautions, Warnings and Dangers.

REAR SUSPENSION

General

NOTICE: Hardware that is removed must be installed in its original position unless otherwise specified. If the torque values are not specified, refer to the Torque Specifications table in the GENERAL INFORMATION AND ROUTINE MAINTENANCE section.

The rear suspension consists of the leaf springs, shocks and the hardware that connects these items together, mounts the springs to the axle and to the vehicle frame. The removal of the rear axle is covered in the section in this book titled REAR AXLE.

Shock Absorber

Tool List	Qty.
Wheel Chocks	4
Jack Stands	4
Floor Jack	1
Wrench, 1/2"	1
Insulated Wrench, 9/16"	1
Wrench, 3/4"	1
Socket, 1/2"	1
Socket, 9/16"	1
Socket, 9/16" Deepwell	1
Extension, 3"	1
Ratchet	1
Torque Wrench, ft. lbs.	1

⚠ WARNING *To decrease the possibility of personal injury, follow the lifting procedure in SAFETY section of this manual. Place wheel chocks in front and behind wheel not being raised and check stability of vehicle on jack stands before starting any repair procedure. Never work on a vehicle that is supported by a jack alone.*

Shock Absorber Removal

1. Remove the vinyl cap (31), hex nut (30), shock washer (28) and rubber shock bushing (29) from the lower end of the shock absorber
2. Remove the hex nut (30), shock washer (28) and rubber shock bushing (29) from the upper end of the shock absorber.
3. Compress the shock absorber (27) and remove it between the frame mounting bracket and the lower mounting plate.

Shock Absorber Installation

1. Install the shock absorber washer (28) with the cupped surface facing upward and the rubber shock

absorber bushing (29) on the top stud of the shock absorber (27).

2. Insert the top stud into the mounting hole on the frame bracket then compress the shock absorber (27) with the shock absorber washer (28) cupped surface facing down and the rubber shock absorber bushing (29) in place, until the bottom stud can be installed into the lower mounting plate.
3. Install a rubber shock absorber bushing (29) and shock absorber washer (28); cupped surface facing down on the upper shock absorber stud. Install the hex nut (30). Tighten the nut (30) until the rubber bushing expands to the same diameter as the shock absorber washer. Install the vinyl cap (31).
4. Install a rubber shock absorber bushing (29) and shock absorber washer (28); cupped surface facing up on the upper shock absorber stud. Install the hex nut (30). Tighten the nut (30) until the rubber bushing expands to the same diameter as the shock absorber washer. Install the vinyl cap (31).

Removal and installation of the shock is the same for both sides of the vehicle.

Replace any worn or damaged hardware with new as required.

Rear Leaf Spring

Tool List	Qty.
Wheel Chocks	4
Jack Stands	4
Floor Jack	1
Wrench, 1/2"	1
Insulated Wrench, 9/16"	1
Socket, 1/2"	1
Socket, 9/16"	1
Socket, 9/16" Deepwell	1
Ratchet	1
Torque Wrench, ft. lbs.	1

NOTICE: If both springs are to be replaced, but the rear axle is not being removed from the vehicle, it is important to replace one spring at a time so that the rear axle is supported at all times.

Springs must be replaced in sets; never replace only one spring.

REAR SUSPENSION

Read all of SAFETY and this section before attempting any procedure. Pay particular attention to Notices, Cautions, Warnings and Dangers.

Rear Leaf Spring Removal

1. Raise the rear of the vehicle in accordance with the instructions provided in SAFETY section of this manual and support the rear of the vehicle with jack stands under the axle tubes clear of the U-bolts and leaf spring mounting plates.
2. Remove the four hex nuts (24) and washers (23) from the U-bolts (21), remove the U-bolts from the leaf spring brackets.
3. Place the floor jack under the rear frame of the vehicle and raise it enough to take pressure from the leaf spring (1) off of the lower leaf spring plate (22) on the rear axle. Support the vehicle frame with another set of jack stands.
4. Remove the hex head bolts (13) and nuts (14) from the shackle plates (12) at the rear of the frame. Remove the flanged urethane bushings (11) and spacers (10) as well.
5. Remove the hex head bolt (3) and nut (5) from the forward leaf spring mounting bracket. The leaf spring (1) can now be removed from the vehicle.

Item	Torque Specification
14	10 - 15 ft. lbs (13.5 - 20.3 Nm)
5	18 - 23 ft. lbs (24.4 - 31 Nm)
24	18 - 20 ft. lbs (24.4 - 27 Nm)

Removal and installation of the leaf spring is the same for both sides of the vehicle.

Replace any worn or damaged hardware with new as required.

Rear Leaf Spring Installation

Spring installation is in the reverse order of disassembly.

1. Install the large flanged bushing (2) in the forward end of the leaf spring (1) and place the leaf spring in the forward mounting bracket.
2. Install the hex head bolt (3), washer (4) and nut (5) to secure the forward end of the leaf spring in the bracket.
3. Install one set of the smaller flanged urethane bushings (11) and spacers (10) in the rear frame mounting holes.
4. Position the shackle plates (12) over the bushings and install the hex head bolt (13) and nut (14).
5. Install the remaining pair of flanged urethane bushings (11) and spacer (10) in the leaf spring (1). Position the leaf spring between the shackle plates (12) and install the hex head bolt (13) and nut (14).
6. Align the pin on the leaf spring (1) with the holes in the leaf spring mounting plates (18 & 22). Install the U-bolts (21) and four washers (23) then secure in place with the four hex nuts (24).
7. Tighten the hardware to the torque value specified below. Make sure that the leaf spring pin remains aligned with the holes in the leaf spring mounting plates.

REAR SUSPENSION

Read all of SAFETY and this section before attempting any procedure. Pay particular attention to Notices, Cautions, Warnings and Dangers.

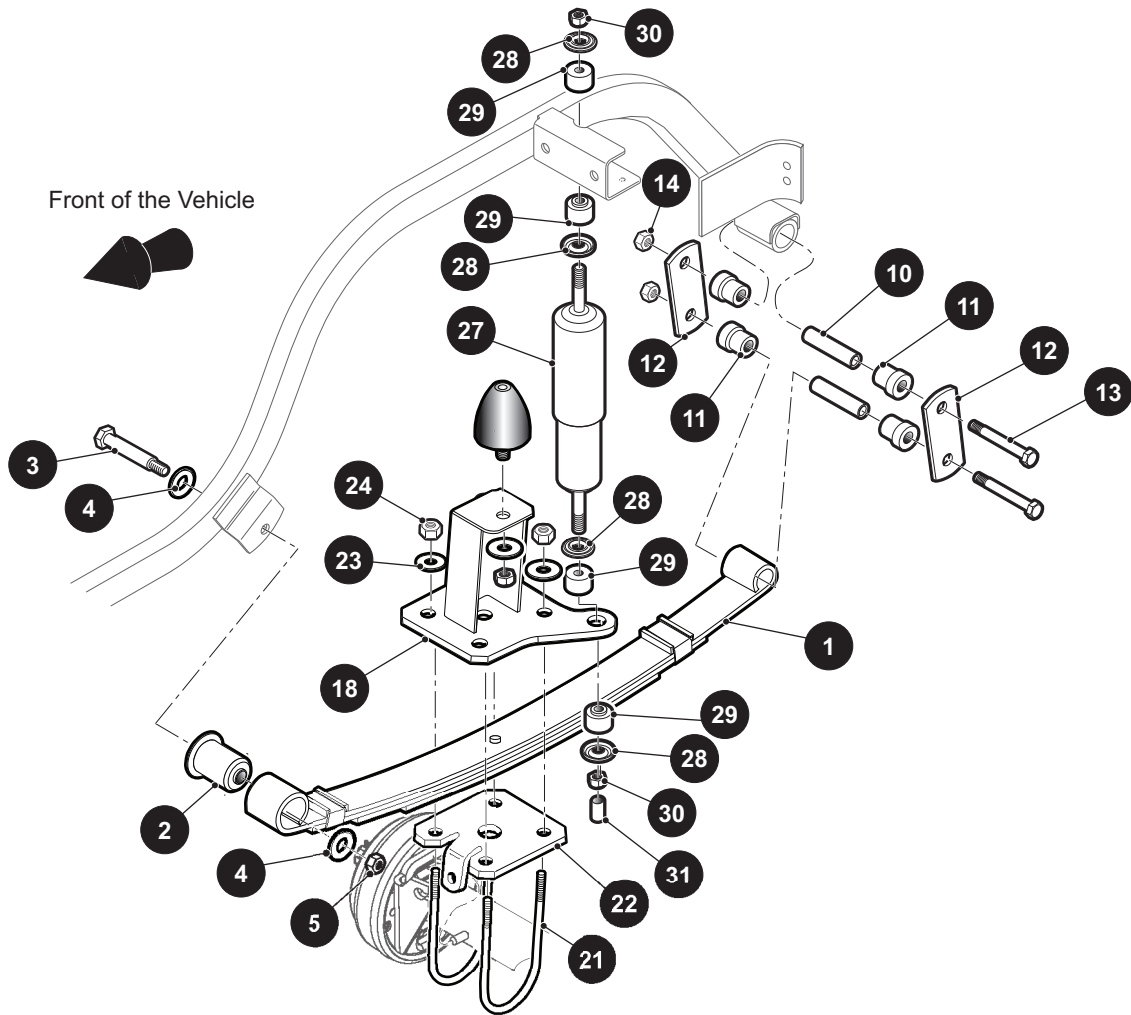

Fig. 1 Rear Suspension

REAR SUSPENSION

Read all of SAFETY and this section before attempting any procedure. Pay particular attention to Notices, Cautions, Warnings and Dangers.

CONTINUOUSLY VARIABLE TRANSMISSION (CVT)

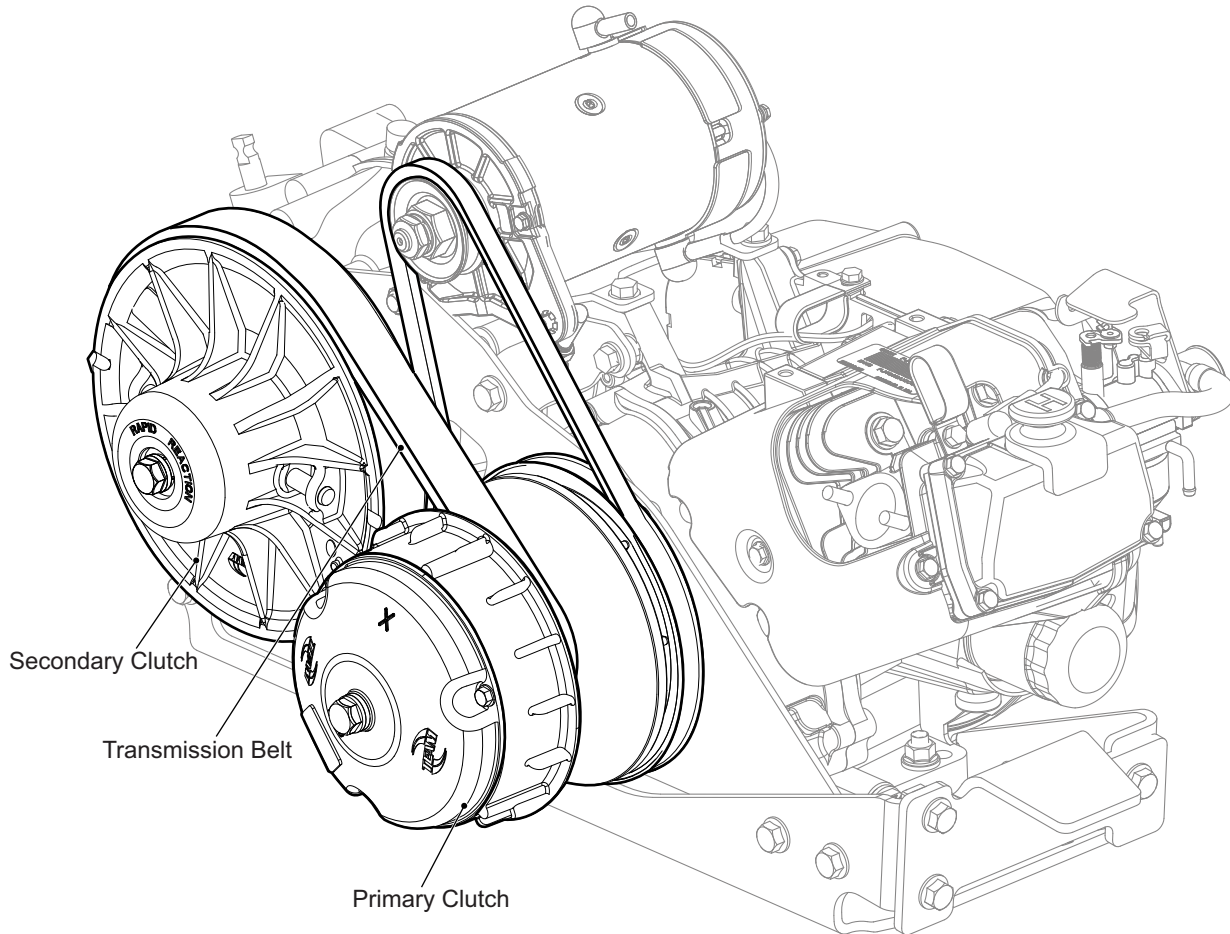

Fig. 1 Continuously Variable Transmission System (CVT)

GENERAL

The power transmission from the engine to the rear axle is with a continuously variable transmission (CVT). The CVT has two matched clutch units joined by a transmission belt (Ref. Fig. 1). The engine mounted primary clutch is a centrifugal unit that responds to engine speed and the rear axle mounted secondary clutch is a load sensing unit.

CLUTCHES

Primary Clutch

When the accelerator is pressed, the engine speed is increased which causes the cams (weights) within the centrifugal primary clutch to move outwards and force the movable sheave inwards. The transmission belt is engaged by the clutch sheaves and begins to rotate.

As the engine speed continues to increase, the primary clutch sheave continues to move inwards forcing the transmission belt to the outer diameter of the primary clutch sheaves, which increases the speed of the belt. The ratio is greatly decreased and supplies maximum speed.

When the accelerator is released, the engine speed decreases and the cams apply less pressure on the movable sheave, which is forced outwards against the cams by a compression spring. The transmission belt disengages from the clutch sheave when engine speed is decreased to the point where the cams apply less force than the spring.

CONTINUOUSLY VARIABLE TRANSMISSION (CVT)

Read all of SAFETY and this section before attempting any procedure. Pay particular attention to Notices, Cautions, Warnings and Dangers.

Secondary Clutch

The secondary clutch sheaves are closed at rest which results in the transmission belt being held at the outer diameter of the secondary clutch. The secondary clutch has no weights but is held closed by a torsion spring which is joined to the movable secondary assembly.

As the transmission belt starts to rotate, the secondary clutch starts to rotate. As the speed of the primary clutch increases and the belt starts to climb the sheaves, the secondary clutch responds by being forced open in order to permit the belt to ride lower in the secondary clutch sheaves. The sheaves overcome the pressure applied by the torsion spring and cam.

As the secondary clutch slows, the belt rides lower in the primary clutch sheaves. The secondary clutch compensates by closing in response to the torsion spring and cam.

Increased Load

When a vehicle traveling at governed speed begins to climb a grade or is subjected to other increased load conditions, a change in wheel speed is detected by the clutch system and the transmission belt seeks a position where it can achieve adequate friction to overcome the load change.

The belt moves outwards on the secondary clutch which closes due to the torsion spring that moves the movable sheave against the torque ramps. The movement of the transmission belt overcomes some of the centrifugal force applied by the cams in the primary clutch.

This forces the belt lower into the primary clutch which increases the drive ratio. This down-shifting applies more torque to the rear axle without an appreciable change to the engine speed since the governor opens the throttle valve in direct the response to the decrease in ground speed.

Equilibrium

The CVT functions because the primary and secondary clutches maintain equilibrium. The clutch sets are adjusted to the vehicle that they are designed to operate. Changes in vehicle weight or desired performance characteristics require that both clutches be adjusted to the needs of the vehicle and stay compatible with each other.

Removing the Transmission Belt

With the vehicle on level ground, remove the transmission belt by pulling the belt to the top which will cause the secondary clutch sheaves to open and loosen the belt tension (Ref. Figure. 2).

The belt can be moved off to the secondary clutch.

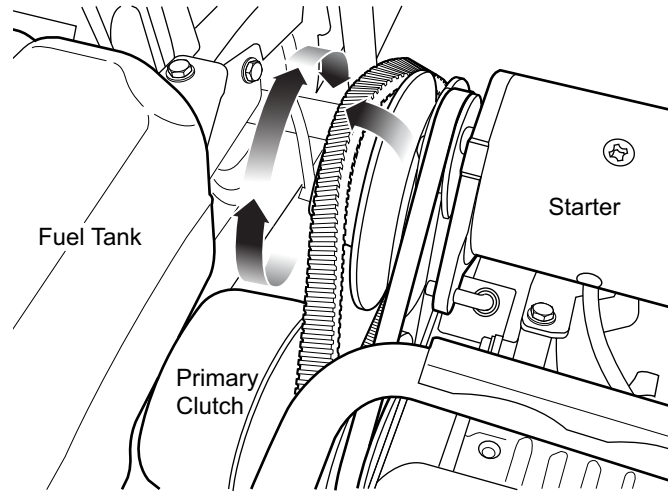

Figure. 2 Removing the Transmission Belt

Transmission Belt Service

If the vehicle has been operated in a very dusty or muddy location, the belt must be rinsed with water. If the belt becomes frayed or badly worn, it must be replaced.

Primary Clutch Removal

Tool List	Qty.
Plastic Faced Hammer.....	1
Clutch Puller, (P/N 608429)	1
Wrench, 18mm.....	1
Socket, 18mm.....	1
Impact Socket, 19mm	1
Impact Wrench (Air or Electric).....	1
Ratchet.....	1
Extension, 8".....	1
Thread Locking Adhesive.....	AR
Torque Wrench, ft. lbs.	1

CAUTION

To decrease the risk of burns and other injuries:

Disconnect the negative (-) battery cable to keep the engine from accidentally starting before removing the transmission belt.

Make sure that the engine and exhaust components have become cool before you work on the vehicle.

Do not allow the fingers to become trapped between the belt and clutch sheave.

Use only sockets designed for use with an impact wrench. Never use a socket intended for use with hand tools.

Remove the CVT belt (1) (Ref. Fig. 3). Remove the Starter/Generator belt (Refer to Starter/Generator

CONTINUOUSLY VARIABLE TRANSMISSION (CVT)

Read all of SAFETY and this section before attempting any procedure. Pay particular attention to Notices, Cautions, Warnings and Dangers.

Removal in ENGINE section).

Remove the bolt (2) from the center of the primary clutch (Ref. Fig. 3).

Raise the vehicle frame with the floor jack and allow the power-train to drop so that the clutch puller bolt clears the spring hanger. Remove the front eye-bolt from the spring hanger. Install the clutch puller bolt using the impact tool and universal joint, remove the primary clutch from the shaft. Remove the clutch puller bolt.

NOTICE: In some cases the clutch cannot separate from the crankshaft. Remove the clutch puller and fill the cavity with grease. Replace the clutch puller and tighten it with the impact wrench. The combined mechanical and hydraulic effect will remove the clutch. Remove all excess grease.

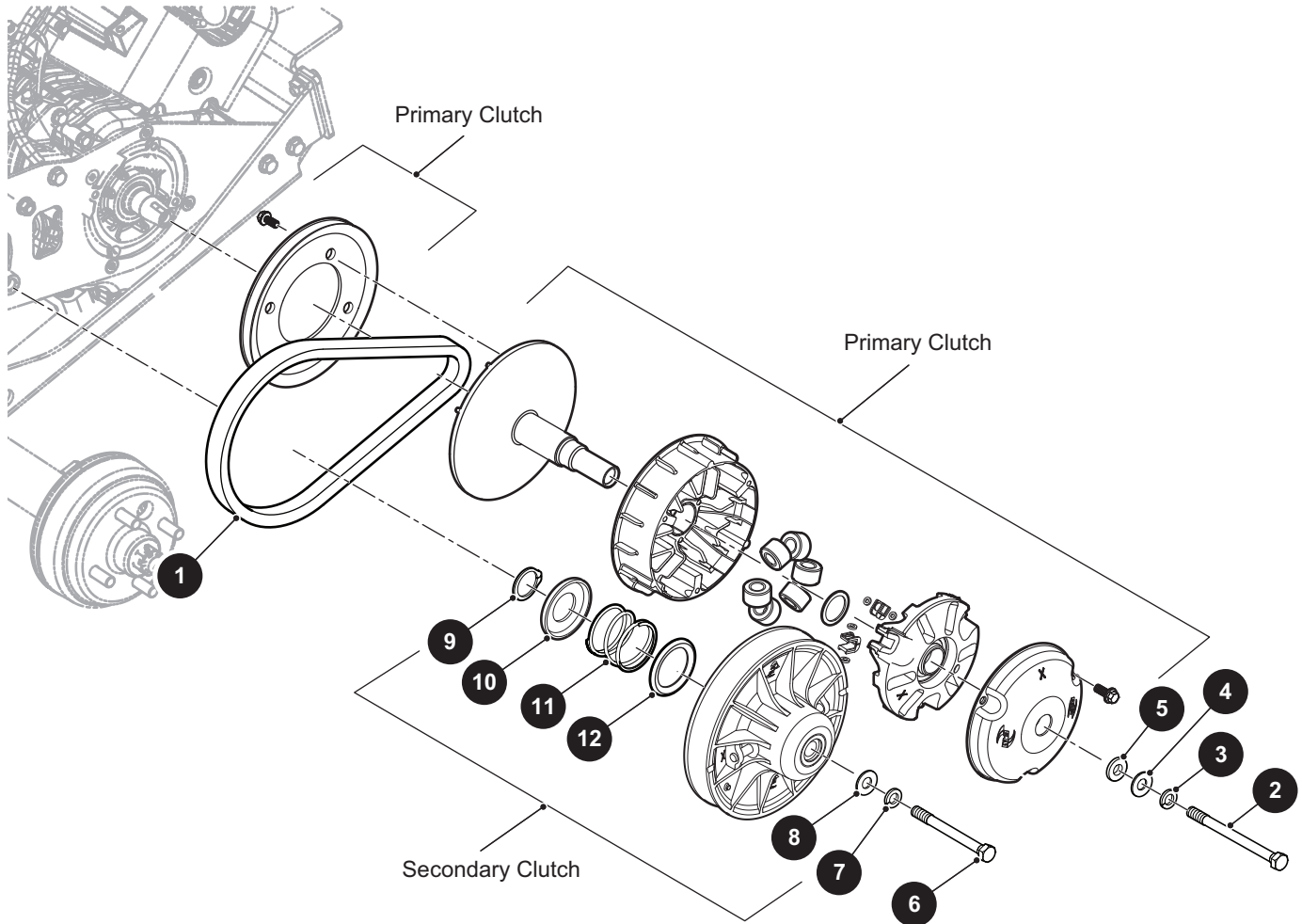

Fig. 3 CVT Components

CONTINUOUSLY VARIABLE TRANSMISSION (CVT)

Read all of SAFETY and this section before attempting any procedure. Pay particular attention to Notices, Cautions, Warnings and Dangers.

Primary Clutch Installation

CAUTION

To decrease the risk of damage to the clutch, be sure to remove all grease from the body of the clutch since grease penetrating the seal can cause premature clutch failure or belt slip.

Do not install the bolt (2) with an impact wrench.

To hold the clutch, do not use a pry bar inserted through the drive clutch as this may damage the components.

Clean both the engine crankshaft and the primary clutch bore. Slide the clutch onto the engine crankshaft and rotate the clutch while lightly pushing the movable sheave in and out several times to seat the clutch on the tapered crankshaft (Ref. Fig. 3).

Install the lock washer (3), conical washer (4) and clutch washer (5) onto the clutch bolt (2).

Apply thread locking adhesive to the threads of the clutch bolt (2) and install. Tighten the bolt to the torque value specified below.

Item	Torque Specification
2	55 - 62 ft. lbs. (74 - 84 Nm)

Secondary Clutch Removal

Tool List

	Qty.
Plastic Faced Hammer	1
Clutch Puller, (P/N 608429)	1
External Snap Ring Pliers	1
Wrench, 18mm	1
Socket, 18mm	1
Impact Socket, 19mm	1
Impact Wrench	1
Ratchet	1
Thread Locking Adhesive	AR
Phillips Screwdriver	1
Torque Wrench, ft. lbs.	1

Remove the transmission belt (1) See "Removing The Transmission Belt".

Remove the passenger side hub cap if equipped and remove the wheel and tire assembly.

Set park brake and place direction selector in F to place tension on clutches.

Access the secondary clutch from the passenger side of the vehicle and remove the bolt (6), lock washer (7) and conical washer (8) from the secondary clutch.

Install the clutch puller bolt until it bottoms out.

Remove the clutch, then remove the clutch puller bolt and slide the clutch from the rear axle input shaft.

Secondary Clutch Repair

NOTICE: The parts must be assembled again in same position as their original position. Mark all components to facilitate accurate reassembly. Some small field repairs may be made to the secondary clutch.

Remove the retaining ring (9) and remove the outer spring retainer (10) (Ref. Fig. 3). Remove the spring (11), inner retainer spring (12) and the movable sheave (13).

Inspect the shaft for indications of wear and inspect the bushings for indications of damage. If there is wear to the point of causing vibration, the clutch must be replaced.

Secondary Clutch Assembly

Assemble the movable sheave (13) to the fixed sheave (14) and insert the spring (11) and inner retainer spring (12) in the pilot hole in the movable sheave (Ref. Fig. 3).

Insert the other end of the spring in the outer retainer spring (10) and rotate counterclockwise 140° before engaging the splines and inserting the retaining ring (9).

Secondary Clutch Installation

Apply a layer of anti-seize compound on the rear axle input shaft and slide the clutch on to the shaft.

Install lock washer (7) and conical washer (8) to the clutch bolt (6) and apply thread locking adhesive to the threads of the clutch bolt.

Install the clutch bolt and tighten to the torque value specified below.

Item	Torque Specification
6	55 - 62 ft. lbs. (74 - 84 Nm)

STORAGE

If the vehicle is to be out of service for an extended period of time, the clutches must not be coated with a protecting spray. The primary clutch sheaves can develop some surface rust that is removed within a few minutes of running time. The secondary clutch is aluminum and does not need any maintenance.

ENGINE

For further engine information, see Engine Shop Rebuild and Service Parts Manual.

POWERTRAIN MAINTENANCE

Access the powertrain by raising or removing seat. Some service procedures may require the vehicle be lifted. Refer to LIFTING THE VEHICLE in the SAFETY section for proper lifting procedure and safety information.

Checking the Oil Level

CAUTION Do not overfill engine. Too much oil may cause smoking or allow oil to enter the air filter enclosure.

NOTICE: Vehicles with the leaf springs mounted on top of the rear axle will have an oil dipstick with an 'H' stamped into the top.

The oil should be checked with the engine warm. The vehicle should be on a level surface with the parking (PARK) brake engaged. Allow adequate time for oil to drain into the crankcase before checking.

Remove the oil dipstick and wipe off the entire area with a lint free cloth (Ref. Fig. 1).

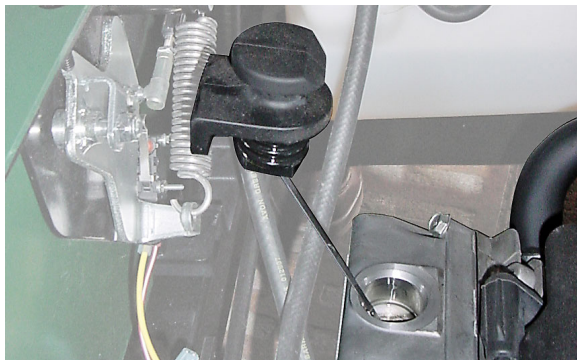

Fig. 1 Oil Dipstick

Insert the dipstick **fully** into the dipstick opening and remove. Examine the level of the oil on the dipstick.

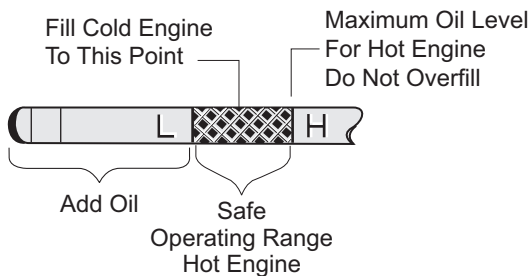

Fig. 2 Check Oil Level on Dipstick

The engine can be operated safely as long as oil is within the safe operating range as indicated on the dip stick. **Do not operate vehicle if oil level is below the safe area indicated on the dipstick.**

Oil should be added to bring the level into the safe operating range. Remember that oil expands as it gets hot, **Do not overfill** (Ref. Fig. 2). Check that the oil cap is firmly in place.

NOTICE: When adding oil between oil changes, do not mix brands and viscosity grades of oil. Both the oil dipstick and fill cap must be in place before operating the engine. Failure to install the dipstick and fill cap will result in oil becoming contaminated and/or oil being discharged into the engine compartment.

Changing the Oil

Tool List	Qty.
Socket, 19 mm	1
Ratchet.....	1
Extension, 8"	1
Oil Drain Pan.....	1
Oil Filter Wrench	1

For maximum performance and longevity, the engine oil should be replaced after the first 8 hours of operation. After the initial oil change, it should be changed every 125 hours of operation or semi-annually, whichever comes first.

The selection of oil is dependent upon the service that the vehicle will perform. Most vehicles require 10W-30 oil, whereas vehicles used at capacity or near capacity load applications will utilize 10W-40 oil after a break-in period of 8 hours (Ref. Fig. 3).

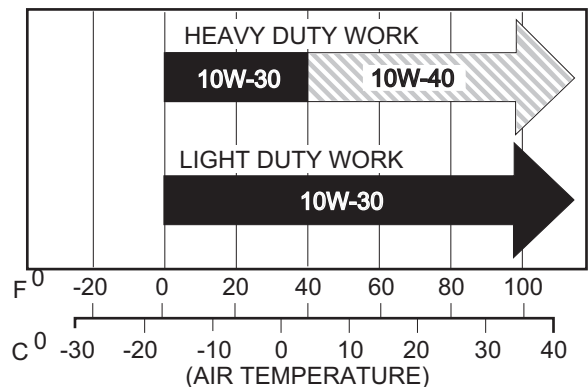

Fig. 3 Oil Viscosity Chart

ENGINE

Read all of SAFETY and this section before attempting any procedure. Pay particular attention to Notices, Cautions, Warnings and Dangers.

NOTICE: If vehicle is to be stored over winter months, it can be stored with old oil left in engine. The oil should be changed as part of spring maintenance. This will remove any moisture that has accumulated during storage.

WARNING Be aware that engine fluids may be hot and contact to the skin may cause severe burns. Wear rubber gloves to protect skin from exposure to the old oil and degreaser.

The oil should be changed with engine warm. Park vehicle on a level surface, engage parking brake and remove key. Place a drain pan under engine. Wipe top of the engine clean with a cloth (Ref. Fig. 4). Remove the oil fill cap.

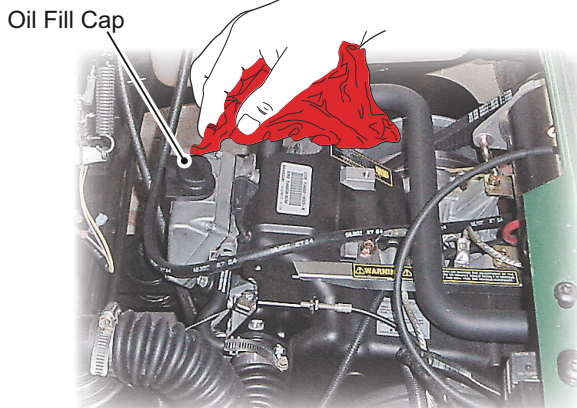

Fig. 4 Cleaning Top of Engine

WARNING Be careful of hot oil when drained. It may be hot enough to burn you.

Place the oil drain pan under the oil drain plug (1) found at the rear of the engine base. Remove the drain plug (1), allow the oil to drain into the drain pan.

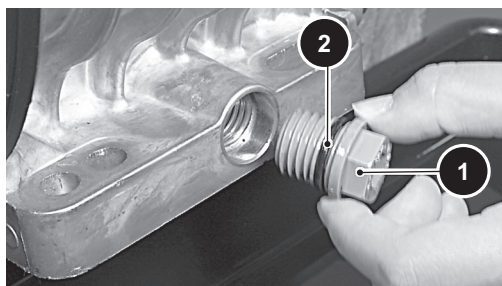

Fig. 5 Oil Drain Plug

Before installing the drain plug clean the area around the drain plug mount with a lint free cloth and inspect the drain plug (1) for damage; replace if necessary (Ref. Fig. 5). If the 'O' ring (2) on the drain plug is damaged replace it with a new one and tighten to the specified torque.

ITEM	TORQUE SPECIFICATION
1	61 in. lbs (7 Nm)

At the first oil change, **small** metal chips and lint may be found. This is normal, resulting from the break-in period. Inspect the filter at every oil change. The presence of large metal chips could indicate possible damage to the engine.

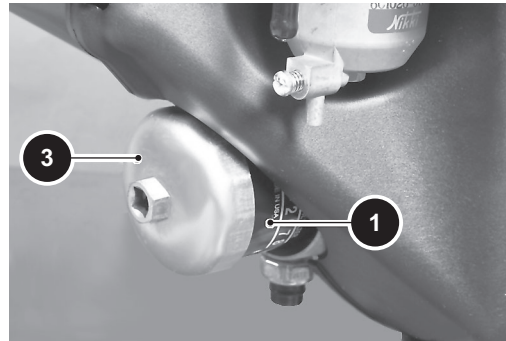

Fig. 6 Remove Oil Filter

Clean the area around filter. Place the oil drain pan under the filter area. Using a filter wrench, strap wrench or other suitable filter wrench (3), remove the filter (4) from the engine and allow the oil to drain into the oil drain pan (Ref. Fig. 6). The 'O' ring (5) may remain on engine (6) or filter (7) (Ref. Fig. 7).

Inspect the filter to make sure the 'O' ring is not left on the engine surface (6), if the 'O' ring has remained on the engine surface remove it and discard with the filter.

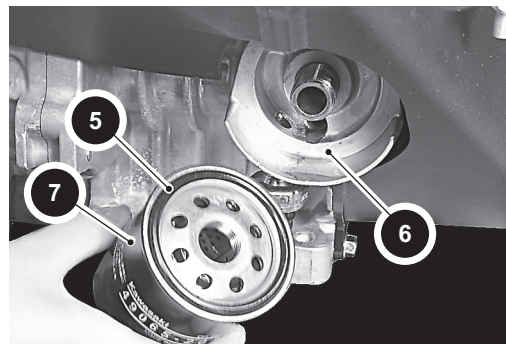

Fig. 7 Inspect Oil Filter

Inspect the new oil filter for any defects, apply engine oil to the 'O' ring seal and install the new oil filter onto the engine until the seal contacts mounting surface of the engine. Then turn the filter 2/3 to 3/4 rotation by hand. Pour in the specified type and amount of oil.

Oil capacity is 1.4 quarts (1.3 liters). Add slightly less than 1.4 quarts (1.3 liters) to allow for possible residual oil left in engine. The oil must be high quality oil that meets or exceeds API SF, SG, CC standards (Ref. Fig. 3). Check oil level on dipstick. Oil should be slightly below 'H' to allow for expansion. If necessary, continue to add oil slowly and allow time for oil to flow down into engine. Check oil level on dipstick. **Do NOT overfill.**

Read all of SAFETY and this section before attempting any procedure. Pay particular attention to Notices, Cautions, Warnings and Dangers.

CAUTION Do NOT overfill engine. Too much oil may cause smoking or allow oil to enter the air filter enclosure.

NOTICE: Both the oil dipstick and fill cap must be in place before operating the engine. Failure to install the dipstick and fill cap will result in oil being discharged into the engine compartment.

As a final check, check the oil level again with the vehicle on level ground. Like all liquids, oil increases in volume when warm. The full 'H' mark on the dipstick is calibrated for an engine at operating temperature. When the engine is cold, the oil will be below the 'H' mark. The engine can be operated safely as long as the oil is within the safe operating range as indicated on the dipstick. **Do NOT operate vehicle if oil level is below the safe area indicated on the dipstick.**

AIR FILTER INSPECTION/REPLACEMENT

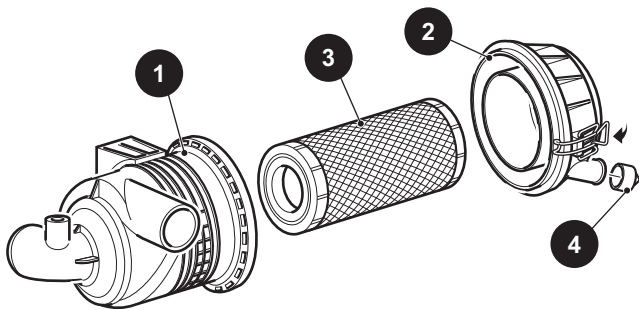

Fig. 8 Air Filter Assembly

NOTICE: The air filter assembly on the vehicle is a dry unit. Do not use oil on the filter element or any part of the unit.

The air cleaner may be accessed by raising the seat. Unsnap two clips that secure the cover (2) to the canister (1) and remove the cover. Remove the air filter element (3) and clean the inside of the cover, canister and dust collector. Inspect the air filter element (3) and replace it in accordance with the SCHEDULED MAINTENANCE CHART section. Install the air filter element (3) and replace the cover (2). Be sure the cover is properly seated and all clips are fastened securely.

Cleaning the Air Filter Element

CAUTION Do NOT use compressed air to clean the air filter. Doing so will damage the filter and will damage the engine.

If the element is in acceptable condition, loose dirt may be removed by tapping the filter lightly. Do NOT use oil on the filter element or any part of the unit. Install the element in the same way it was removed, being sure that the cover clips are fastened securely.

STARTER/GENERATOR BELT TENSION

Tool List	Qty.
Belt Tension Gauge	1
Wrench, 13 mm	1
Wrench, 14 mm	2
Wrench, 15 mm	1
Ratchet	1
Socket, 13 mm"	1
Socket, 15 mm	1

The starter/generator belt tension should be checked after the first 15 - 20 hours and set to 17 - 18 lbs. (75 - 80 N).

WARNING At no time during installation of belt, should the belt tension exceed 36 lbs (160 N).

CAUTION At the time of installation, the belt must not be rolled over the installed edges of the starter/generator or drive clutch pulleys. Excessive stretch in belt may cause cord failure.

NOTICE: A loose belt can cause audible vibration and squeal.

Tighten a new starter/generator belt to 25 - 29 lbs. (110 - 130 N) tension when a gauge is applied half way between the two pulleys (Ref. Fig. 9).

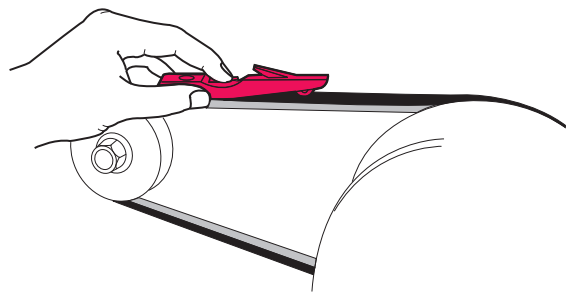

Fig. 9 Checking Belt Tension with Gauge

Although not as accurate, a new belt may be pressed with a finger. A maximum deflection of 3/8" (10 mm) is acceptable (Ref. Fig. 10).

ENGINE

Read all of SAFETY and this section before attempting any procedure. Pay particular attention to Notices, Cautions, Warnings and Dangers.

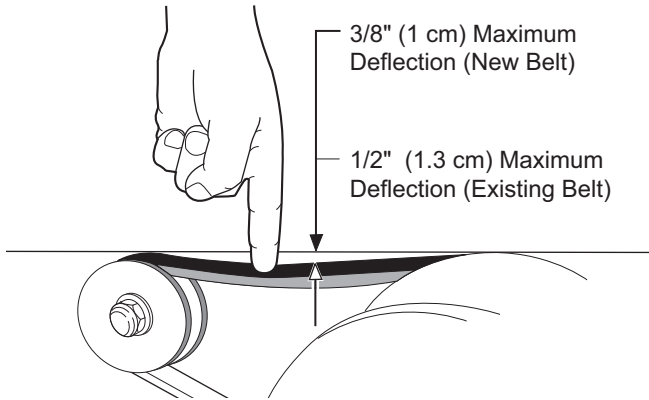

Fig. 10 Checking Belt Tension with Finger

Re-tighten an **existing** belt to 17 - 18 lbs. (75 - 80 N) tension using the same technique. A maximum deflection of 1/2" (13 mm) is acceptable.

Adjusting the Belt

Loosen the two pivot bolts (13) and nuts (14) on the starter/generator. Using two 14 mm wrenches; hold the lower nut (11) and loosen the upper nut (12) on the starter/generator adjusting bolt.

Move the lower nut (11) up or down the adjustment bolt until proper belt tension is achieved. Hold the lower nut (11) in place and tighten the upper jam nut (12) against it the lower nut to the specified torque value (Ref. Fig. 11).



Fig. 11 Adjusting the Belt Tension

Using a socket and open end wrench, tighten the starter/generator pivot bolts (13) and nuts (14) to the specified torque value.

ITEM	TORQUE SPECIFICATION
12, 14	30 - 35 ft. lbs (40 - 48 Nm)

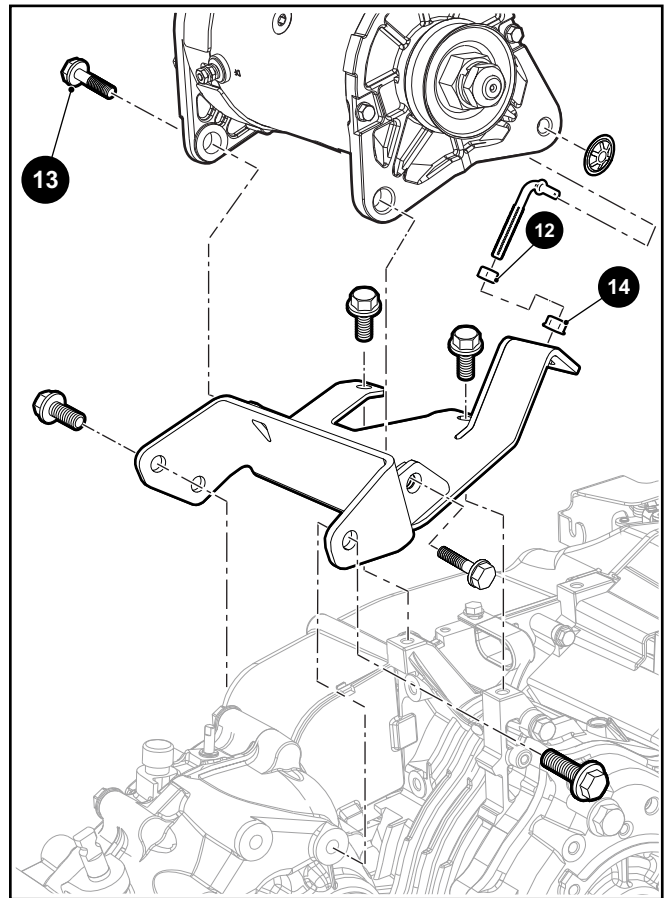

Fig. 12 Starter/Generator

STARTER/GENERATOR REPLACEMENT (REF. FIG. 12)

Tool List	Qty.
Wrench, 8 mm.....	1
Wrench, 10 mm.....	1
Wrench, 13 mm.....	1
Wrench, 14 mm.....	2
Wrench, 15 mm.....	1
Ratchet.....	1
Socket, 13 mm.....	1
Socket, 15 mm.....	1
Torque wrench, ft. lbs.....	1

⚠ WARNING To prevent possibility of personal injury, disconnect negative (-) battery cable before beginning starter/generator removal.

Remove the wiring from the starter/generator. Loosen the jam nut (11) and the adjusting nut (12) securing the starter/generator adjuster until the starter/generator belt

Read all of SAFETY and this section before attempting any procedure. Pay particular attention to Notices, Cautions, Warnings and Dangers.

can be removed from the drive clutch. Remove the starter/generator pivot bolts (13) and lift starter/generator from the vehicle.

Install the starter/generator pivot bolts (13) and hardware loosely in place and install the belt. Tighten a new starter/generator belt per 'Starter/Generator Belt Tension' earlier in this section.

Tighten jam nut (12) and the pivot bolts (13) and nuts (14) to the specified torque shown in the torque table earlier in this section.

Install the wiring and tighten the terminals firmly into place. Reconnect the battery.

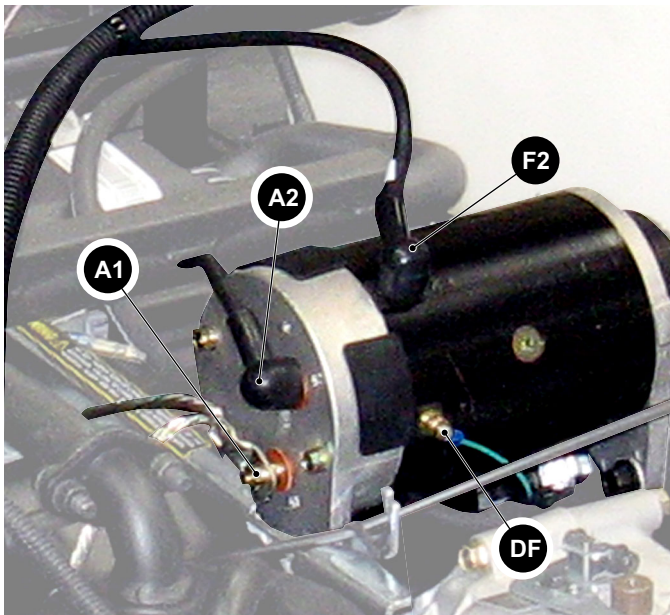

Fig. 13 Starter/Generator Wire Connections

FROM	TO
A1	Ground
A2	Terminal F1 on Starter/Generator
F1	Terminal A2 on Starter/Generator
F2	Terminal A on Solenoid
DF	Green wire to Voltage Regulator

Fig. 14 Starter/Generator Wiring Table

COOLING SYSTEM CLEANING

At least once a year, or more often under adverse conditions, the cooling system should be cleaned. Cleaning will assure an adequate supply of air to the cooling fins. Compressed air may be used for routine cooling system maintenance.

Operation in wet or damp weather or overly fresh cut grass may result in a variety of debris accumulating and adhering to the internal shroud and fins of the cooling system.

SPARK PLUG

Tool List

Qty.

Spark Plug Socket, 13/16"	1
Feeler Gauge, wire type	1
Ratchet & Extension	1
Torque Wrench, ft. lbs	1

This engine uses Spark Plug NGK BPR2ES with a gap of .028" - .031" (.70 - .80 mm). Using a 13/16" spark plug socket or wrench, remove the spark plug at 125 hours or semi-annually and clean and re-gap. The spark plug should be properly gapped (Ref. Fig. 15) and replaced in the cylinder head, tighten to the specified torque.

ITEM	TORQUE SPECIFICATION
Spark Plug	16 ft. lbs (22 Nm)

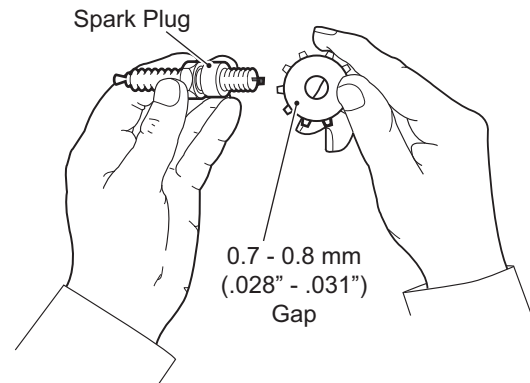

Fig. 15 Gapping the Spark Plug

Fouled spark plugs are indicated by a wet, black appearance. This could be caused by a dirty air filter element or other restrictions in the air intake system. Incorrectly adjusted valves, spark plug wires which are in poor condition or poor quality fuel could also contribute to the problem.

CAUTION

Use care not to over-tighten the plug. Over-tightening can cause damage to the aluminum cylinder head threads.

ENGINE

Read all of SAFETY and this section before attempting any procedure. Pay particular attention to Notices, Cautions, Warnings and Dangers.

FOUR CYCLE ENGINE

Engine Specifications

Engine Model	FJ400-D
Type	Four Cycle, Overhead Valve
Number Of Cylinders	1
Displacement	401 cc
Rated Horsepower	13 hp
Spark Plug Type	NGK BPR2ES
Spark Plug Gap028" - .031" (.70 - .80 mm)
Cooling	Forced Air Cooled
Oil Filter	Cartridge Type Full Flow Filter
Oil Pump	Positive Displacement Pump

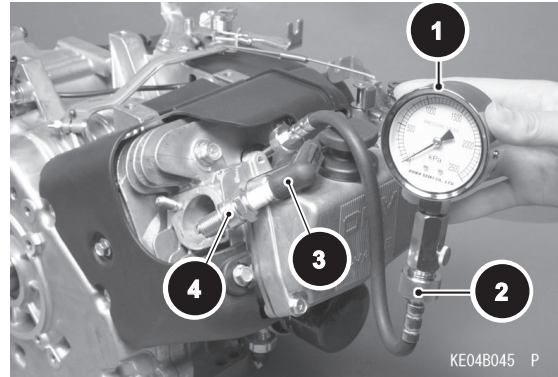

Fig. 16 Compression Gauge

Engine Description

The engine is an air cooled, 4-stroke, overhead valve, single cylinder gasoline engine. It incorporates a pressure fed lubrication positive displacement oil pump with a cartridge type full flow oil filter and a counter rotating balance shaft.

CYLINDER HEAD

Compression Measurement

Tool List	Qty.
Ratchet	1
Spark Plug Socket	1
Extension 6"	1
Compression Gauge & Adapter (20 kgf/cm ²)	1

Before measuring compression, do the following:

- Be sure the battery is fully charged.
- Thoroughly warm up the engine so that engine oil between the piston and cylinder wall will help seal compression as it does during normal running.
- Stop the engine.

Disconnect the spark plug cap (3) and remove the spark plug (4) keeping the engine throttle fully open.

Attach the compression gauge (1) to the adapter (2) and insert firmly into the plug hole.

Place the spark plug cap (3) on the removed spark plug (4) and ground the spark plug to the engine.

⚠ WARNING *To prevent possibility of personal injury or fire, do not ground the spark plug in proximity to the plug hole. Keep the plug as far away as possible from the plug hole. Fuel drawn into the cylinder will be expelled through the spark plug opening and could be ignited by the ignition system or another source, resulting in a fire.*

Using the starter motor, turn the engine over with the throttle fully open until the compression gauge stops rising.

Cylinder Compression should be between 9 - 11 kgf/cm² (128-156 psi).

If the compression is higher than 9 kgf/cm² (128 psi) the piston rings, cylinder and valves are probably in good condition.

If the compression is over 11 kgf/cm² (156 psi), check the following:

1. Carbon build-up on the piston crown and cylinder head - clean off any carbon on the piston crown and cylinder head.
2. Cylinder head gasket - use only the proper gasket. The use of a gasket of incorrect thickness will change the compression.
3. Valve guides and piston rings - rapid carbon accumulation in the combustion chamber may be caused by worn valve guides and/or worn piston oil rings. This may be indicated by white exhaust smoke.

If cylinder compression is lower than 9 kgf/cm² (128 psi), check the following:

1. Gas leakage around the cylinder head - replace the damaged head gasket and check the cylinder head for warp.

Read all of SAFETY and this section before attempting any procedure. Pay particular attention to Notices, Cautions, Warnings and Dangers.

2. Condition of the valve seating.
3. Valve clearance.
4. Piston/cylinder wear, piston seizure.
5. Piston ring, piston ring groove.

Rocker Cover Removal

Tool List

	Qty.
Ratchet	1
Extension 6"	1
Socket, 10 mm	1

1. Remove the four bolts (5) securing the rocker cover.
2. Remove the rocker cover (2) and the gasket.

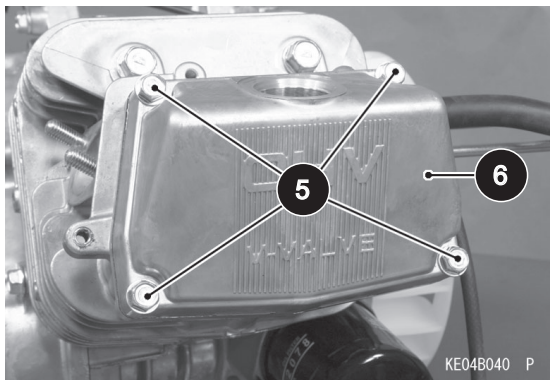

Fig. 17 Rocker Cover

Valve Clearance Inspection

Tool List

	Qty.
Allen Bit, 3 mm	1
Ratchet	1
Extension 6"	1
Feeler Gauge	1
Wrench, 14 mm	1
Torque Wrench, in. lbs.....	1

NOTICE: Valve clearance must be checked when the engine is cold (at room temperature).

With the rocker cover removed, Place the piston at TDC of the compression stroke turning the crankshaft in its rotational direction.

Then check the valve clearance with a feeler gauge (7), measure the valve clearance between the rocker arm (8) and the valve stem end.

Valve Clearance (when cold): Inlet, Exhaust 0.10 - 0.15 mm (0.004 - 0.006 in.)

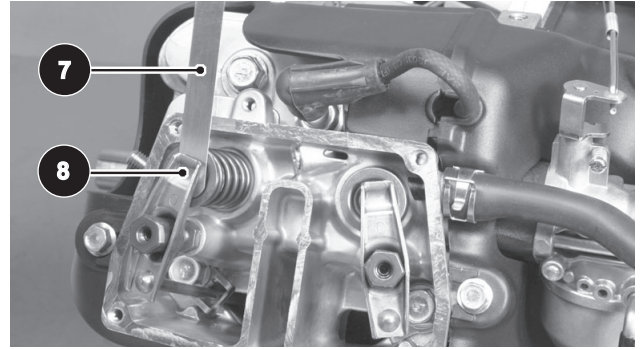

Fig. 18 Measure Valve Clearance

If the valve clearance is incorrect, adjust it.

Valve Clearance Adjustment

Turn the crankshaft to the proper direction until the piston is at TDC of the compression stroke.

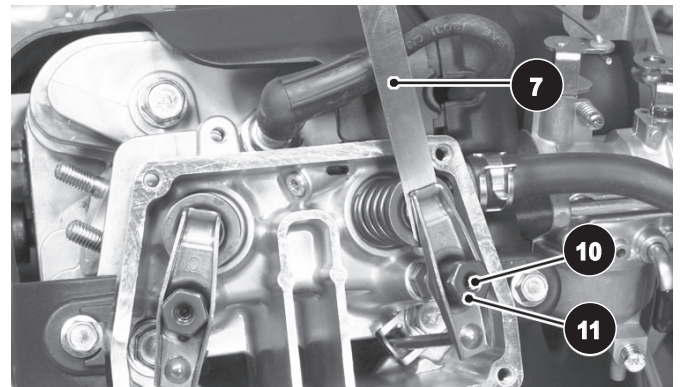

Fig. 19 Valve Clearance Adjustment

Valve Clearance (when cold): Inlet, Exhaust 0.10 - 0.15 mm (0.004 - 0.006 in.)

Loosen the lock screw (10) using the 3 mm Allen bit and the adjusting nut (11). Insert the feeler gauge (7) between the rocker arm and the valve stem end and move the adjusting nut (11) until the feeler gauge begins to bind between the rocker arm and the valve stem end.

Hold the adjusting nut (11) in place using a wrench and tighten the lock screw (10) to the specified torque.

ITEM	TORQUE SPECIFICATION
10	61 in. lbs (6.9 Nm)

CAUTION Do NOT over-tighten.

Remeasure any clearance that was adjusted. Readjust if necessary.

Replace the Rocker Cover (6), gasket and the four bolts (5). Tighten the bolts to secure the cover in place.

ENGINE

Read all of SAFETY and this section before attempting any procedure. Pay particular attention to Notices, Cautions, Warnings and Dangers.

ENGINE REMOVAL

Tool List	Qty.
Socket, 10 mm.....	1
Socket, 12 mm.....	1
Socket, 14 mm.....	1
Socket, 1/2".....	1
Socket, 5/8".....	1
Impact Socket, 19 mm.....	1
Wrench, 8 mm.....	1
Wrench, 10 mm.....	1
Wrench, 12 mm.....	1
Wrench, 13 mm.....	1
Wrench, 14 mm.....	2
Wrench, 15 mm.....	1
Wrench, 19 mm.....	1
Combo Wrench, 19 mm.....	1
Pliers.....	1
Extension 6".....	1
Ratchet.....	1
Flat Ratchet.....	1
Impact Tool.....	1
Straight Blade Screwdriver.....	1
Drip Pan.....	1

This section covers the removal and installation of the engine, for information on rebuilding the engine please see the Engine Shop Rebuild Manual for this vehicle.

NOTICE: In the following text, there are references to removing/installing bolts etc. Additional hardware (nuts, washers etc.) that are removed must always be installed in their original positions unless otherwise specified. Non specified torque specifications are as shown in the table contained in the GENERAL INFORMATION AND ROUTINE MAINTENANCE section.

This operation will remove the engine through the top of the engine compartment. The weight of the engine exceeds normal OSHA limits for one person; therefore, a second person or an engine hoist will be needed to remove the engine. If a hoist is employed, it will be necessary to remove the sun top.

1. Disconnect Battery ground wire.
2. Disconnect air hose at throttle body.
3. Jack up rear of vehicle as directed in the SAFETY section of this manual. Use jack stands for stability.
4. Remove the drive belt by rotating clutch toward rear of vehicle when the belt is slipped off the top of the clutch. Remove belt from vehicle.
5. Disconnect the 'DF' wire from the starter using 8mm wrench, lay harness out of the way
6. Remove the ground strap from the Starter/Generator using a 10 mm socket.

7. Disconnect the F2 power cable from the top of the starter.
8. Starter/Generator (See Starter/Generator Replacement in this section).
9. Remove the ground strap at the crankcase using the 10 mm socket. Route ground strap through bracket and under the throttle rod and cover.
10. Disconnect the fuel line from the injector, use drip pan to catch any fuel leakage.
11. Remove throttle rod cover using a 6" extension and a 10 mm socket. Remove the throttle rod at the throttle plate using a pliers to pop the retaining tab from the throttle rod and lift throttle rod out of hole. Remove throttle rod at rear by rotating 45 degrees from the bracket and lift through the bracket slot and remove rod from vehicle.
12. Remove both bolts from starter/generator bracket using a 15 mm wrench.
13. Remove the 12mm hardware that secures the header flange to the muffler flange.
14. Remove the four 15 mm bolts from the engine support bracket connecting the engine to the differential and the engine to the inner frame.
15. Remove the 15 mm bolts from the bottom of the skid plate. Access the forward two nuts through the oil drain access hole.

Controls and Wiring

Disconnect the 12 pin engine-harness connector joining the main harness to the engine harness.

Removing the Engine from the Vehicle

NOTICE: Place suitable blocks under the engine frame for support. the alignment of the frames and simplify engine installation.

NOTICE: It is not necessary to remove the muffler as part of the engine removal.

Read all of SAFETY and this section before attempting any procedure. Pay particular attention to Notices, Cautions, Warnings and Dangers.

Engine Installation

CAUTION *It is important to follow the assembly sequence recommended for mounting hardware.*

1. With the assistance of a hoist or another person, lower the engine into position over the engine support castings.
2. Install one rear horizontal and one front bottom engine bolt through the casting and engine and lightly snug in place.
3. Install the remaining horizontal engine bolts and finger tighten. Remove the front bottom bolt and reinstall the skid plate finger tight.
4. Tighten the bottom and horizontal mounting bolts to 45 ft. lbs. (60 Nm) torque.
5. The remaining installation is in the reverse order of disassembly using standard torque specifications.

DRIVE CLUTCH REMOVAL

WARNING *To prevent the possibility of personal injury, use only impact sockets when using an impact wrench.*

Insert a clutch puller bolt (p/n 608429) into the clutch and hand tighten for several turns.

Remove the clutch by driving it off with the impact wrench and the clutch puller bolt.

NOTICE: *In some extreme cases, the clutch will be resistant to removal. In stubborn cases the clutch removal tool should be removed and the cavity filled with grease. Install the clutch puller and use the impact wrench to drive off the clutch. The combination of hydraulic pressure (grease) and the impact wrench will remove the most stubborn clutch. To prevent damage to the clutch, be sure to remove all grease from the body of the clutch since grease penetrating the seal may cause premature clutch failure.*

It is not necessary to remove the engine to remove the clutch. Refer to the **CONTINUOUSLY VARIABLE TRANSMISSION (CVT)** section for removal and installation.

FUEL SYSTEM

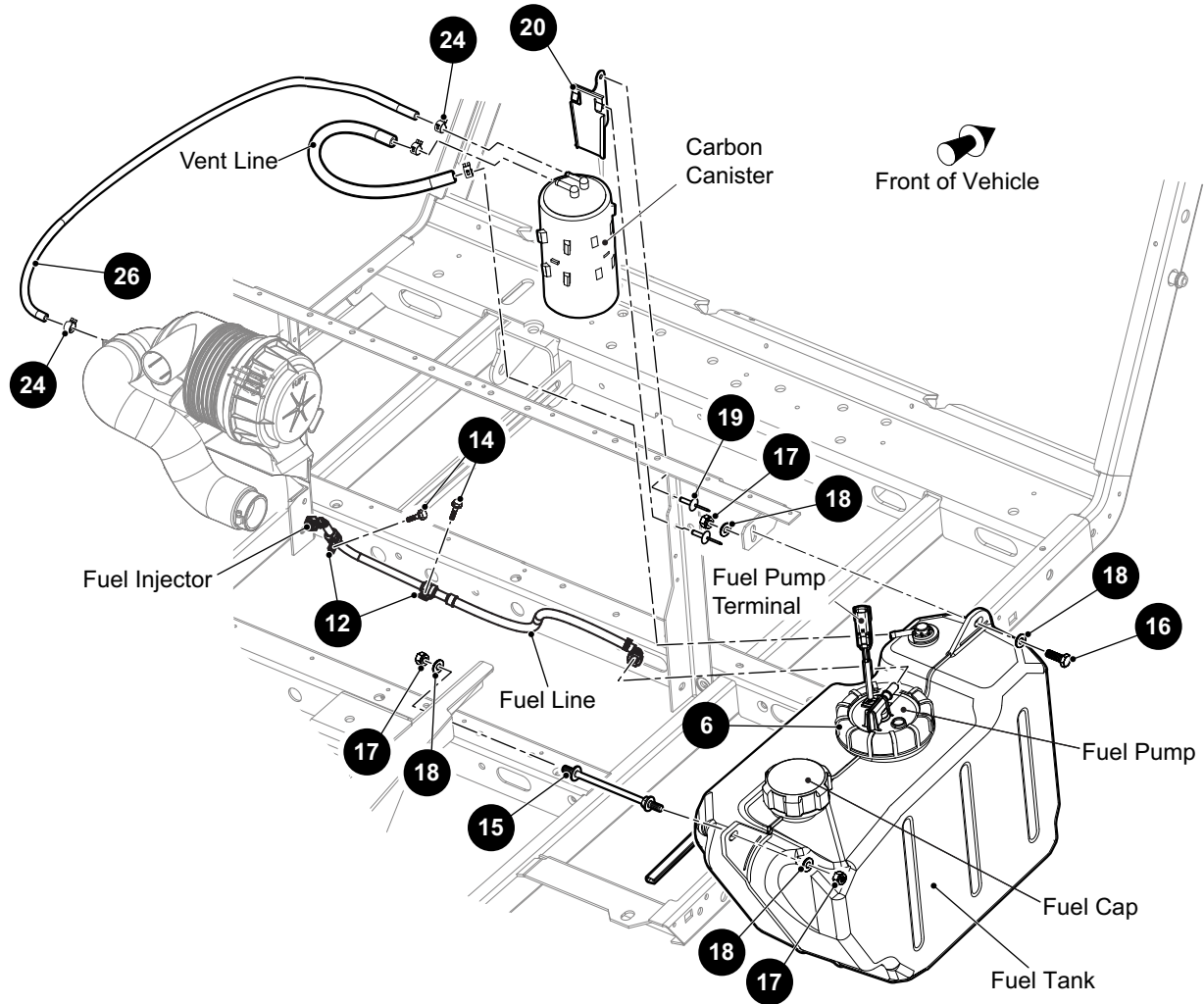

Fig. 1 Fuel System

FUEL SYSTEM

Read all of SAFETY and this section before attempting any procedure. Pay particular attention to Notices, Cautions, Warnings and Dangers.

GENERAL

NOTICE: Hardware that is removed must always be installed in its original position unless otherwise specified. If torque values are not specified, refer to the Torque Specifications Table. See TORQUE SPECIFICATIONS on page 6.

An electric fuel pump supplies fuel from the fuel tank to the engine injection system through the fuel line (See Fig. 1). The fuel filter is located in the fuel tank along with the fuel pump.

FUEL

⚠ WARNING To prevent serious injury or death resulting from a possible explosion, do not smoke near the fuel tank or refuel near open flame or electrical items that could produce a spark.

Always wear safety glasses while refueling to prevent possible eye injury from gasoline or gasoline vapor.

When refueling, inspect the fuel cap for leaks or breaks that could result in fuel spillage.

Do not handle fuel in an area that is not adequately ventilated. Do not permit anyone to smoke in an area where vehicles are being fueled.

The fuel tank is located under the seat on the passenger side of the vehicle. Fill the tank with fresh, 87 octane (minimum) gasoline. See RECOMMENDED LUBRICANTS AND FLUIDS on page 139.

Do not use fuel with ethanol content greater than 10%.

Do not mix oil with gasoline.

NOTICE: Some fuels, called oxygenated or reformulated gasoline, are gasoline blended with alcohols or ethers. Excessive amounts of these blends can damage the fuel system or cause performance problems. If any undesirable operating symptoms occur, use gasoline with a lower percentage of alcohol or ether.

Do not over fill the fuel tank. Allow adequate space for the expansion of gasoline.

FUEL SYSTEM SERVICE

⚠ WARNING A clogged or kinked fuel line can be a safety hazard if fuel leaks onto a hot engine.

Tests that involve fuel flow should be avoided if possible. If a test to determine fuel/vapor presence or flow is required, the ignition system must be disabled to prevent an ignition spark that could ignite

the fuel/vapor. Never permit smoking or an open flame in an area that contains fuel/vapor. Clean up all fuel spills immediately.

Never attempt to repair a damaged or leaking fuel tank. It must be replaced.

Disconnect the negative (-) battery cable before servicing the fuel system.

The fuel tank, fuel line, vent line and fuel tank cap should be checked frequently for leaks, clogs or damage (See Fig. 1).

Fuel Tank Removal

Tool List	Qty.
Wrench, 5/16"	1
Socket, 5/16"	1
Ratchet.....	1
Drain Pan	1
Siphon pump.....	1
Fuel Container	1

1. Disconnect the negative (-) battery cable with an insulated wrench.
2. Remove the fuel from the tank with a siphon pump that is safe for use with gasoline.

NOTICE: Always dispose of fuel safely.

3. Press the tab to disconnect the fuel pump wire located at the top of the fuel tank (See Fig. 2).



Fig. 2 Fuel Pump Wire

FUEL SYSTEM

Read all of SAFETY and this section before attempting any procedure. Pay particular attention to Notices, Cautions, Warnings and Dangers.

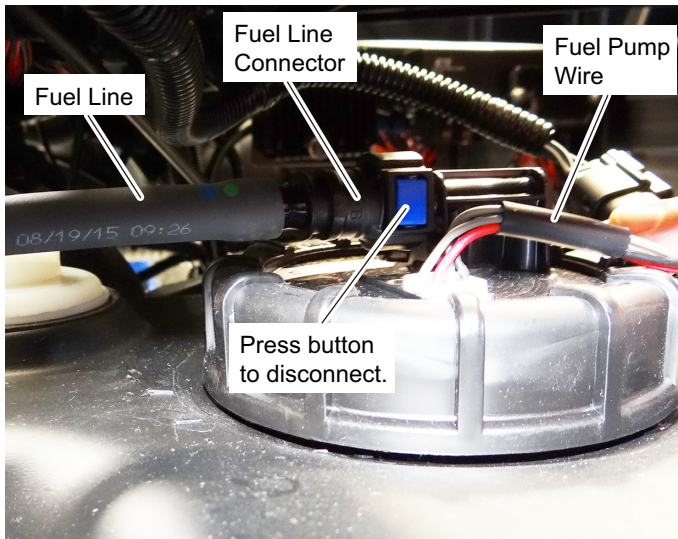

Fig. 3 Fuel Tank Connections

4. Disconnect the fuel line from the tank by pressing the button on the fuel line connector while pulling the connector away from the tank (See Fig. 3). Plug the fuel line to prevent fuel leakage.
5. Disconnect the tube (12) to the carbon cannister.
6. Remove the forward hex nut (17), washers (18), and bolt (16).
7. Remove the rear nut (17), washers (18) and spacer (15).
8. Remove the tank from the engine compartment.
9. Installation is in reverse order of removal (Ref. Fig. 1).
10. Remove the fuel tank.
11. Installation is in reverse order of removal.

NOTICE: Make sure that the fuel line and vent line are not kinked or restricted by wire ties, etc.

Fuel Pump Assembly

Tool List	Qty.
Strap Wrench	1

NOTICE: The electric fuel pump, fuel filter, float and fuel gauge sending unit are integrated into one complete assembly (See Fig. 4). If any of these components fail, the complete assembly must be replaced.

1. Remove the fuel tank. See *Fuel Tank Removal* on page 104.
2. Remove the pump assembly (3) by removing the hold-down ring (6) and gasket (5) (See Fig. 4).

3. Pull the fuel pump assembly up and out of the fuel tank.
4. With the fuel pump assembly removed, inspect the hold-down ring seal (4) for damage. Replace as necessary.
5. Installation is in the reverse order of disassembly.

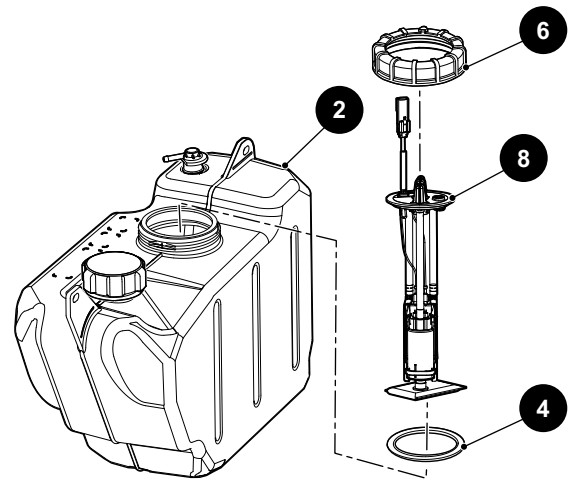

Fig. 4 Fuel Pump

FUEL INJECTOR REMOVAL

Tool List	Qty.
Socket, 5/16"	1
Socket, 10mm	1
Torx Bit, T21	1
Ratchet	1
Drip Pan	1

1. Disconnect the negative (-) battery cable.
2. Remove the air intake hose.
3. Remove the throttle guard.
4. Disconnect the wire terminal from the injector.
5. Remove the screw (14) that secures the fuel line to the engine.
6. Disconnect the fuel line from the fuel injector. Use a drip pan to catch any fuel that may leak from the fuel line, dispose of the spent fuel properly.
7. Remove the bolt that secures the fuel injector to the engine.
8. Remove the injector from the engine.
9. Installation is in reverse order of removal (Ref. Fig. 1).

FUEL SYSTEM

Read all of SAFETY and this section before attempting any procedure. Pay particular attention to Notices, Cautions, Warnings and Dangers.

CARBON CANISTER

Tool List

Qty.

- Flat Blade Screwdriver 1
- To remove the carbon canister (22), disconnect the EVAP hose (12) from the carbon cannister (22) (Ref. Fig. 1).
 - Disconnect the fuel line hose (26) from the carbon canister (22).
 - Press the tabs on the mounting bracket (20) and slide the canister upward.
 - To install the carbon canister (22), position the canister ears above the mounting bracket (20) and push against the bracket and slide the canister (22) onto the bracket past the tabs.
 - Install EVAP hose (12) on the tube closest to the mounting bracket.
 - Install the fuel line hose (26) on the remaining tube.

MALFUNCTION INDICATOR LIGHT (MIL)

The EFI system uses Diagnostic Trouble Codes to report issues. Both active and stored faults are reported by the Engine Control Module (ECM).

- Active Faults – These are faults that have been triggered since the key switch was last turned to the ON position.
- Stored Faults – These are faults that are no longer active. These faults have not been triggered since the key switch was last turned to the ON position. They were active at one time but were stored when the key switch was turned to the OFF position some-time in the past.

These faults can be read from the MIL located under the

front seat. A series of flashes indicates each fault code. A description of how to read codes from the MIL is detailed below. More information about each fault can be obtained from a service technician with the proper equipment.

Follow the below procedure to read, active and store vehicle faults from the MIL:

- Lock the vehicle’s direction selector in Neutral.
- View the MIL by removing the front seat bottom.
- Turn the key switch to the ON position
- Observe the sequence of flashes. Each code is separated by five seconds of solid illumination.
 - Single-digit fault codes display as a sequence of one-second flashes, with the number of flashes matching the code value (e.g. 8 flashes for MIL code 8).
 - Double-digit fault codes display as a combination of 0.3-second flashes for the tens place and 1-second flashes for the ones place.
 - Active faults are displayed first, then stored faults are displayed.
 - Active faults are displayed whether the engine is running or not. Stored faults only display when the engine is not running.

If there are no active or stored faults, the MIL will illuminate continuously (no flashes) to demonstrate functionality.

The ECM will enter sleep mode after 60 minutes of inactivity. If the key switch is in the ON position and the MIL is not illuminated, press and release the accelerator pedal to wake the system and reveal any active fault codes.

MIL Flash Code	Fault	Recovery Steps
1	Temp Sensor Disconnected / Failure	1. Check that the sensor is connected. 2. If connected, contact an authorized service rep.
2	Throttle Position Sensor Failure	1. Contact an authorized service rep.
4	O ₂ Sensor Disconnected / Failure	1. Check that the sensor is connected. 2. If connected, contact an authorized service rep.
5	High Battery Voltage	1. Verify battery voltage is between 10-16 VDC. 2. If voltage is over 16 VDC, contact an authorized service rep.
5	Low Battery Voltage	1. Verify battery voltage is between 10-16 VDC. 2. If the voltage is below 10 VDC, replace the battery. 3. If the fault persists, contact an authorized service rep.
SOLID	Safeties Active	1. Press and release the accelerator pedal. 2. If the fault is still present while the accelerator pedal is pressed, contact an authorized service rep.

Read all of SAFETY and this section before attempting any procedure. Pay particular attention to Notices, Cautions, Warnings and Dangers.

MIL Flash Code	Fault	Recovery Steps
8	Engine Running Rich / Lean	1. Verify that the air filter is not clogged. 2. If the fault persists, contact an authorized service rep.
22	Limp Home	1. Contact an authorized service rep.

WALBRO IRIS SERVICE TOOL EFI DIAGNOSTICS

Communication Module

The Diagnostic USB Communication Module is used for communicating with the ECM real-time as shown in Figures 1 and 2 below.

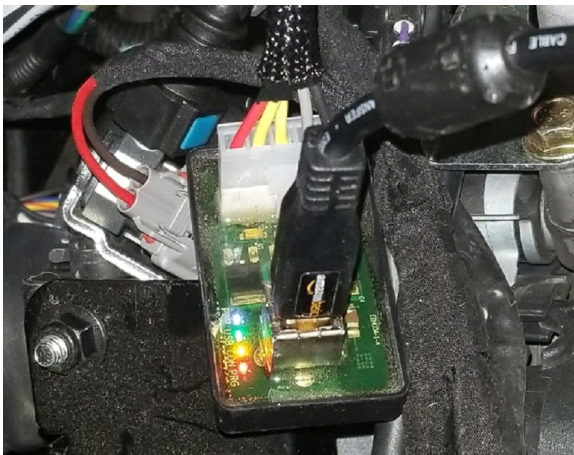

Fig. 5 USB Communication Module ready for ECM programming

The LED Indicators:

- PWR – White – Indicates Battery Power to the Module
- USB – Green – Indicates connected to the PC USB
- CON – Yellow – Indicates they key switch is powered on
- PRG – Red – Indicates the module and ECM are in program mode

Jumper Harness

Figures 3 and 4 below show the jumper harness that connects between the engine and vehicle.



Fig. 7 Jumper Harness



Fig. 6 USB Communication Module with LED indicators on Bottom Right

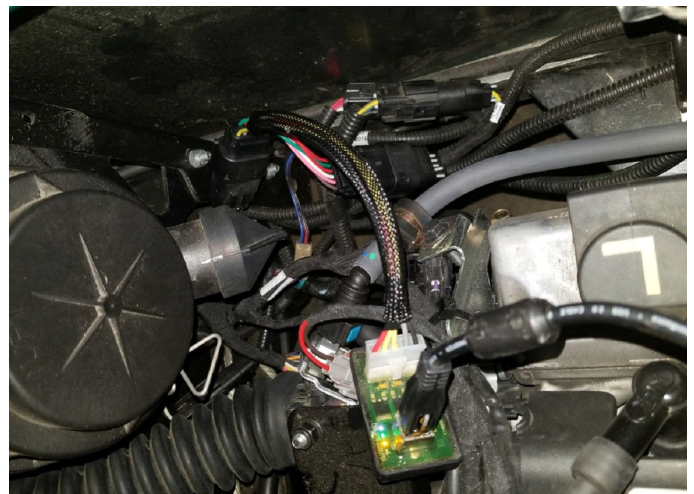

Fig. 8 Jumper Harness Installed in Vehicle

FUEL SYSTEM

Read all of SAFETY and this section before attempting any procedure. Pay particular attention to Notices, Cautions, Warnings and Dangers.

Connect to Vehicle

1. Prepare the vehicle:
 - a. Ensure the vehicle's parking brake is on.
 - b. Remove the vehicle seat.
 - c. Ensure the FNR selector is in the neutral lock-out position.
4. Disconnect the 12-pin connector between the engine harness and the vehicle harness.

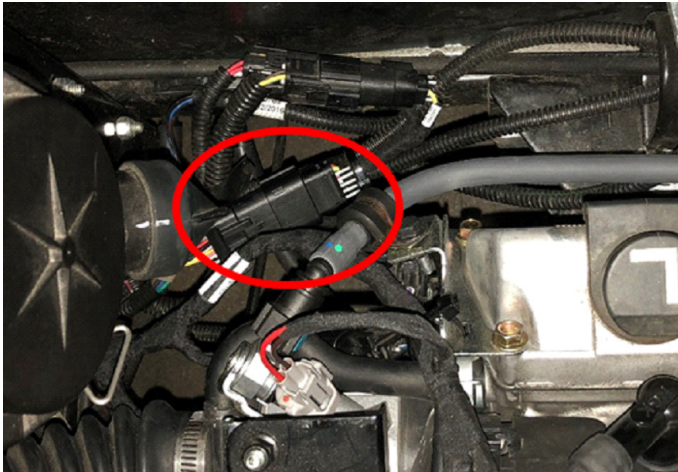

Fig. 9 Engine Compartment 12-Pin Connector

5. Connect the diagnostic jumper harness to each of its mating 12-pin connectors. Ensure there is a positive latch that locks them together.
6. Route the USB cable out of the engine compartment. Make sure it does not contact sharp corners or get pinched

Download software file from TSV Connect

Connect to the ECU

1. On your computer, launch the IRIS tool.

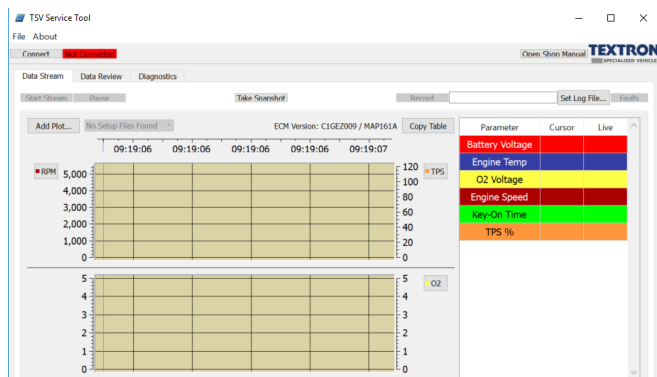

Fig. 10 IRIS Tool Home Screen

2. Turn the vehicle key to the "ON" position.

3. Plug the USB cable into your computer's USB port.
4. Click the "Connect" button at the top left of the IRIS tool.
 - a. If an error appears, close the error, and try to connect again.
2. Press "Start Stream" (under the "Connect" button) to begin streaming live data from the ECM.

Parameters for Viewing

The following is a list of parameters available for viewing, along with a short description of what each parameter represents:

- Battery Voltage – Shows the battery voltage.
- Engine Temp – Shows the engine temperature sensed from the engine temp sensor.
- O2 Voltage – This is the raw voltage output from the oxygen sensor.
- RPM – This displays the current engine speed in RPM.
- Key-On Time – Time in seconds since the key was turned on.
- TPS % - Displays (in %) the position of the throttle plate.

Streaming must be active to read these values from the ECM (press "Start Stream").

Record Log File

1. Engine data can be recorded and viewed afterward for troubleshooting.
2. Navigate to the Data Stream tab
3. Ensure streaming is active (press "Start Stream" if not already pressed). If not, it is possible to collect an empty log file with no indications of the error.
4. Click the "Set Log file..." button
5. Navigate to the folder you want to save the log into, name the file, and click OK.
6. To start recording, click Record (near "Set Log File..." button)
7. To stop recording, click Record again.

View Log File

1. To view recorded data, navigate to the Data Review tab.
2. In the top-left corner, click File->Open
3. Find and select the log file in question. Click Open.
4. The green bar at the bottom of the screen shows the loading status of the file. When loading large files, it

Read all of SAFETY and this section before attempting any procedure. Pay particular attention to Notices, Cautions, Warnings and Dangers.

sometimes stops moving at certain points. This is normal.

5. An empty plot will appear. To show data traces, right-click in the tan plot area and select a channel from the "Available Data" flyout menu. Repeat until all desired channels are selected.
6. Additional plots can be added to display channels separately. Use the "Add Plot" button in the top-left corner to create a new empty plot.
7. To change the vertical axis range, right-click and select an option from the "Scale Behavior" flyout menu. "Manual" allows exact min and max values to be entered.

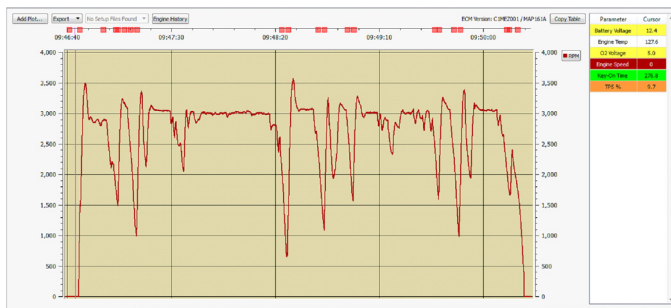

Fig. 11 Data Review

8. The scroll wheel allows zooming in and out of the plot. The area to be focused on is determined by the cursor position (hover over the area of interest while scrolling).
9. The Engine History button shows the Stored Faults as they would have appeared when the log was taken.
10. The ECM version when the log was taken is shown in the top-right.
11. The time scale is shown at the top in hh:mm:ss format. A more precise value is shown next to the cursor as it moves across the plot. Hint: calculating a time difference is best accomplished by referring to the Key-on Time variable instead of the time of day.
12. Green and red squares may appear on the time scale at the top, as seen in Figure 7. These are diagnostic indicators. Hovering the cursor over each square reveals the event information and precise time stamp. Examples: "Safeties Active" (indicating pedal up/grounded kill line), "Temp Sensor Disconnected", "Limp Home Mode". The "Safeties Active" fault is typically not an indication of an issue. It only signifies that the accelerator pedal has been released, which signals to the ECM to stop injecting fuel.
13. Multiple log files can be opened simultaneously by using File->Open again. The different logs will occupy individual tabs, shown at the bottom of the screen.

Update ECM

WARNING Before starting the update procedure:

Make sure the laptop is plugged into a charger.

Ensure the USB cable is routed in so that there is no risk of it coming unplugged.

Ensure the computer does not go to sleep/hibernate or shut down during the update.

Any of the scenarios in the warning above has a chance to corrupt the ECU, requiring removal and replacement of the entire throttle body assembly.

1. Select "Load Engine Config" from the File menu.

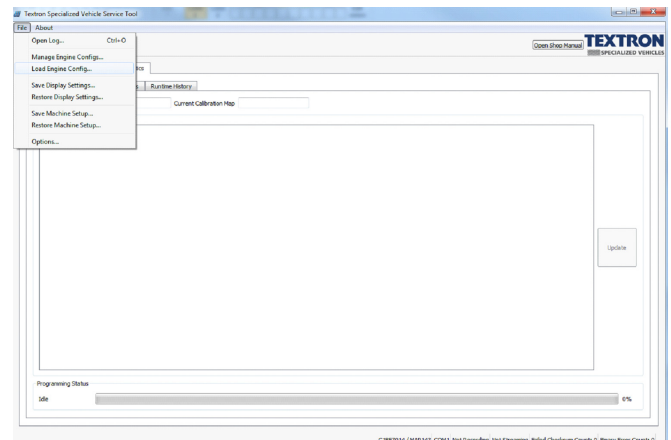

Fig. 12 IRIS Tool File Menu

2. Navigate to the location of the downloaded map update. Select and open the appropriate map.

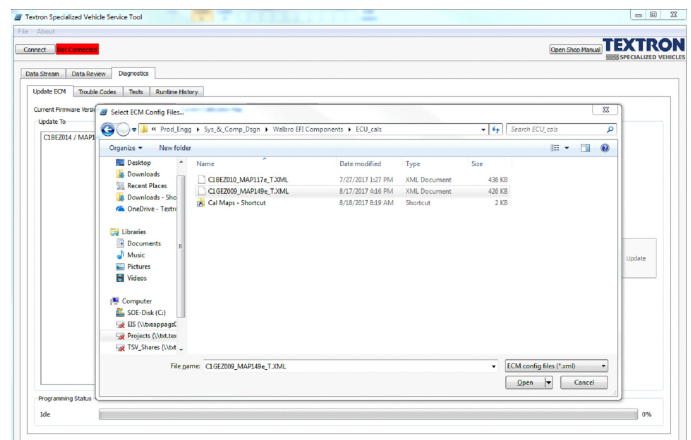

Fig. 13 ECM Selection Window

FUEL SYSTEM

Read all of SAFETY and this section before attempting any procedure. Pay particular attention to Notices, Cautions, Warnings and Dangers.

- Click "OK" to load the map.

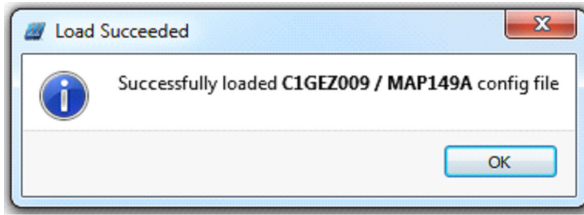

Fig. 14 Completion of ECM Map Loading

- Stop streaming (Data Stream tab).
- Navigate to the "Update ECM" tab, used to update the ECM Software. Update procedure as follows:
 - Select the desired file and then click the "Update" button.

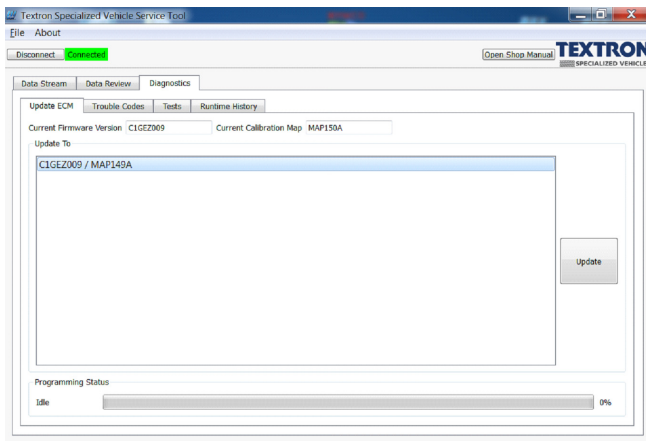

Fig. 15 IRIS Tool Update ECM Tab

- Verify the red LED is on to indicate that the ECM is in program mode. Cycle the key power, and then press "OK".

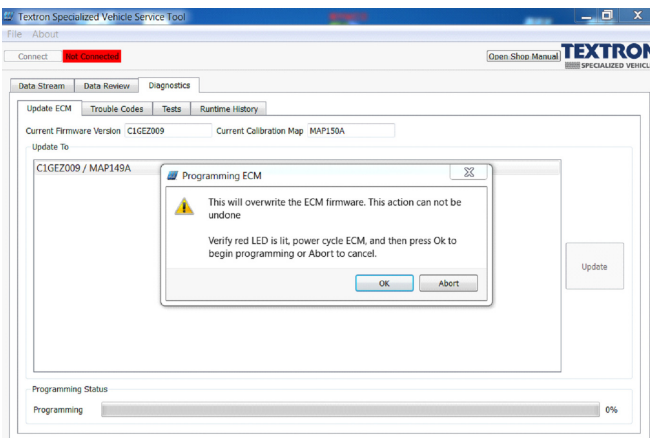

Fig. 16 Programing ECM Window

- The Status Bar at the bottom of the IRIS tool "Update ECM" tab window will start showing programming progress. The yellow LED on the USB

Communication module will pulse during programming.

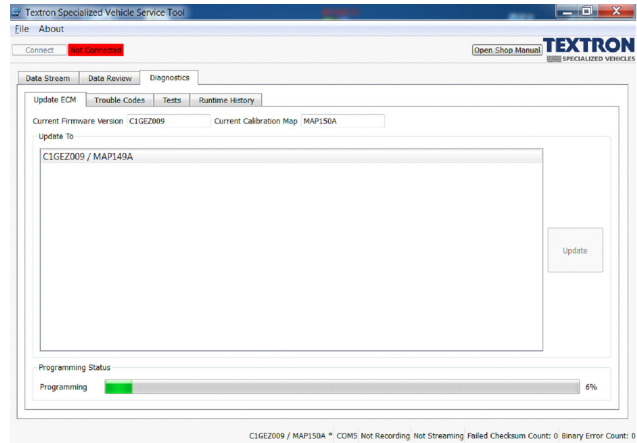

Fig. 17 IRIS Update ECM Window

- A message will pop up indicating the programming is finished. You will need to cycle the key power again and then click "OK" in the pop up window.

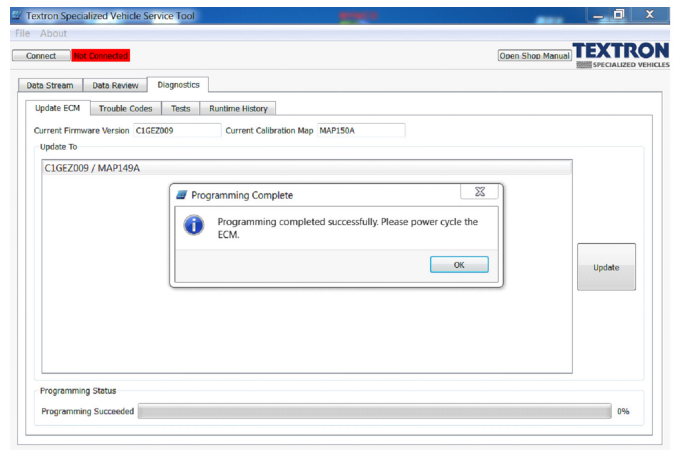

Fig. 18 Successful Program Update Window

Troubleshooting

If there is an error encountered, such as lost communication or a time-out:

- Click "OK" and click the "Connect" button in the IRIS window.
- If it will not reconnect after multiple attempts, turn off the key, remove the USB cable, turn on the key, and reinsert the USB cable to the laptop, and click the "Connect" button in the IRIS window.
- If it still will not reconnect, the ECU is corrupted. The throttle body assembly must be removed and replaced with a new functioning unit.

Read all of SAFETY and this section before attempting any procedure. Pay particular attention to Notices, Cautions, Warnings and Dangers.

Fault Check

The Walbro EFI system uses Diagnostic Trouble Codes to report issues. Both active and stored faults are reported by the ECM.

- Active Faults – These are faults that have been triggered since the key was last switched to the “ON” position.
- Stored Faults – These are faults that are no longer active. These faults have not been triggered since the key was last switched to the “ON” position. They were active at one time but were stored when the key was turned to the “OFF” position sometime in the past.

A more detailed description and basic troubleshooting can be found by clicking on the faults when they appear on the Diagnostics->Trouble Codes tab in the software.

These faults can be read from the MIL typically located under the vehicle’s seat. A series of flashes indicates each fault code. A description of how to read codes from the MIL is found in the vehicle owner’s manual and service manual. Note that the MIL will not operate when the diagnostic dongle is connected to the vehicle. In this case, the faults are instead passed to the diagnostic software.

Follow the below procedure to view active and stored vehicle faults in the software:

1. Turn the vehicle key to the “ON” position.
2. Press Start Stream.

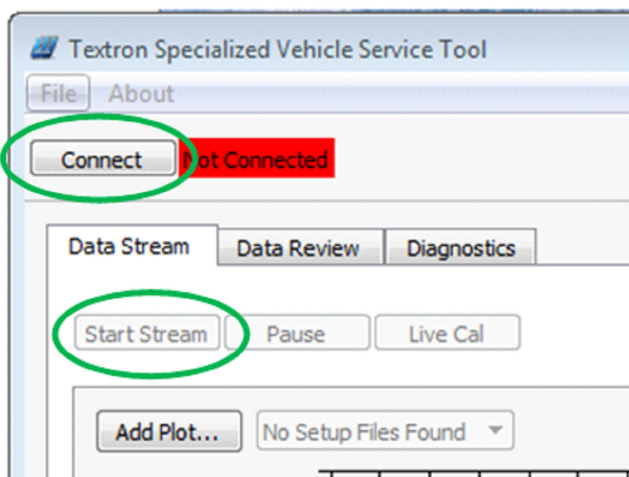

Fig. 19 Connect and Start Stream Buttons

3. Navigate to the Diagnostics Tab.
4. Navigate to the Trouble Codes sub-tab

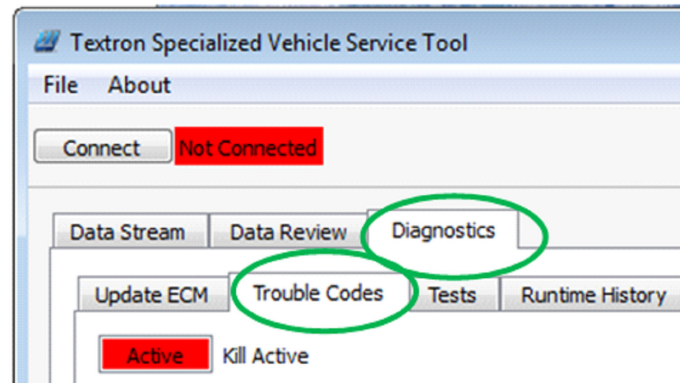

Fig. 20 Trouble Codes Tab

5. Press “Request Stored Faults” at bottom.

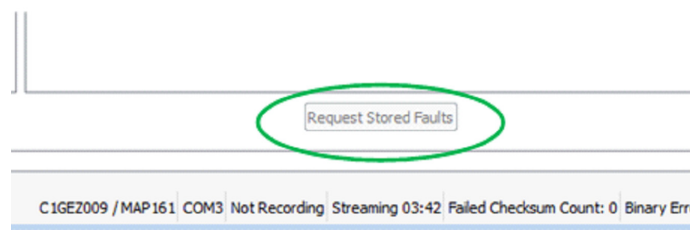

Fig. 21 Requested Stored Faults Button

6. Now the software displays the Active Faults and Stored Faults in the area shown.

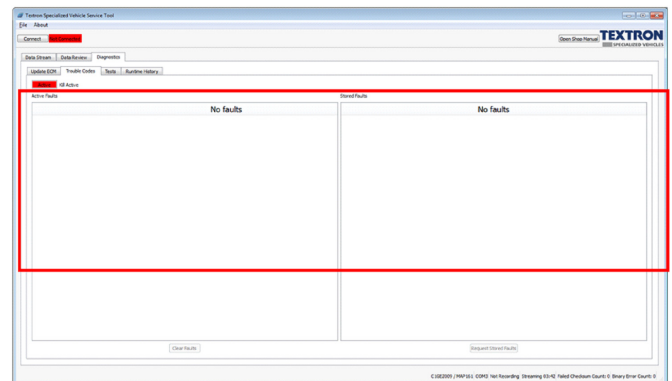

Fig. 22 Fault Codes Display Area

7. Current ECM hours are found on the Diagnostics tab and Runtime History sub-tab in a field called Engine Hours in the top left (see Figure 19). Hours are reported on initial software connection. If the vehicle is run any significant amount while connected, the software should be disconnected and reconnected to refresh the hour count. This hour reading should correlate closely with the reading of a vehicle’s hour meter, if installed, since both record pedal-down

FUEL SYSTEM

Read all of SAFETY and this section before attempting any procedure. Pay particular attention to Notices, Cautions, Warnings and Dangers.

time. However, if the throttle-body/ECM assembly is replaced, the hour count will be restarted from zero.

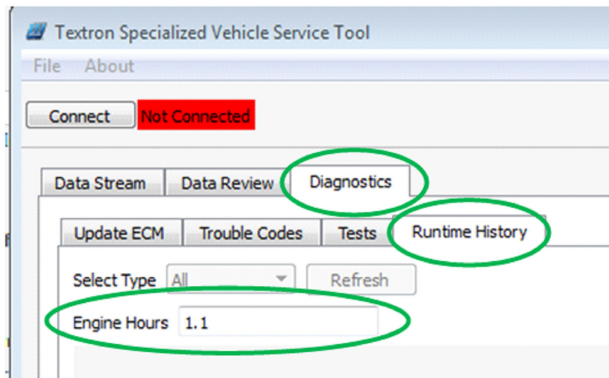

Fig. 23 Engine Hours Display

Active Faults may be cleared to determine when/if the fault recurs under observation. Stored Faults cannot be cleared.

Active Faults do not become Stored Faults until after a key cycle or 60-minute inactivity timeout. For instance, if during a run, Engine Running Lean and Limp Home Mode faults are thrown, regardless of the number of instances seen in the log, their occurrence will only increment the Stored Fault counter once when the key is cycled.

Pedal Kill Check

The accelerator-pedal system contains a kill switch that sends a signal to the ECM to shut off fuel when the pedal is released. This provides better stop/start performance and prevents accidental running when the pedal is up. If the throttle hangs open for any reason, the engine will still shut down when the pedal is released.

To test this system, follow this procedure:

1. Ensure the neutral lockout is engaged, the key is in the "ON" position, the software is connected, and streaming is active.
2. Navigate to the Diagnostics-> Trouble Codes section, as shown.

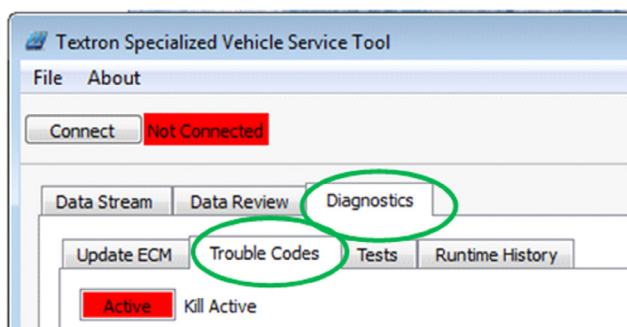

Fig. 24 Trouble Codes Tab

3. Note the condition of the "Kill Active" light, shown directly under the Trouble Codes tab.

4. With the pedal in the resting ("up") position, the kill indicator should display "Active".
5. When pedal moved away from the resting position, the kill indicator should show "Not Active". Warning: if the key is on, the engine will start during this step! Ensure the FNR selector is locked in Neutral and area is safe.

Tests

Diagnostic Tests are available for troubleshooting the EFI system. These can be accessed by navigating to Diagnostics->Tests

These are the three tests available:

- Test Injector – Injector is pulsed 10 times over 11 seconds, unless manually turned off.
- Test Ignition – Ignition is pulsed 10 times over 11 seconds, unless manually turned off.
- Test Fuel Pump Relay – This test runs for 20 seconds, unless manually turned off.

RECOMMENDED FAULT TESTS

Ignition System

1. Disconnect the two pin connection from the ignition Coil. Turn the key to the ON position. Within 10 seconds, measure the voltage between the terminal #2 and the battery ground. Voltage should measure the same as the battery voltage.

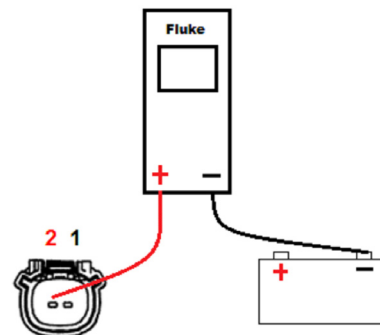

2. Disconnect the two pin connection from the ignition coil. Measure for continuity between the terminal #2 at the ignition coil and the terminal #8 at the ECM.

FUEL SYSTEM

Read all of SAFETY and this section before attempting any procedure. Pay particular attention to Notices, Cautions, Warnings and Dangers.

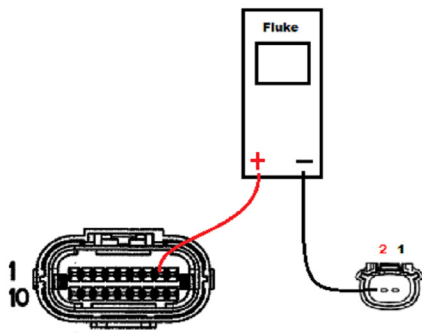

3. Measure the spark plug gap. Make sure the gap is correct.
4. Replace the spark plug.
5. Replace the spark plug cap.
6. Reconnect the high tension lead, the ignition coil and the spark plug cap. Make sure the screw engages the center wires in high tension lead.
7. Check all connections. With the engine running, wiggle each connection. If the engine stops running or runs poorly, check for wire damage.
8. Replace the wiring harness.
9. Replace the ignition coil.
10. Measure the resistance between the IGN module mounting bolt and the high tension lead at the spark plug connection in the cap. Reading should be 13.7~14.7 kΩ.

Fuel Pump

1. Turn the key to the ON position. Within 10 seconds, measure the voltage between terminal #1 at the fuel pump connection and the battery ground. Verify input voltage to pump is 9.0 to 15.0 VDC.

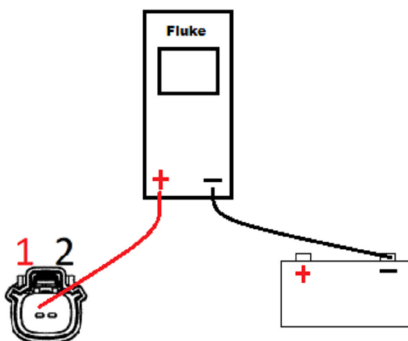

2. Verify at least 1.0 amp of current is available. Use jumper wire (with in-line 5 amp fuse) to connect the fuel pump to the battery positive terminal.

3. Verify that there is sufficient fuel in the fuel tank.
4. Verify that the fuel filter is not contaminated with debris.
5. Swap the fuel filter/hose with a new filter and rubber hose.
6. Verify the outlet hose is not pinched, kinked or leaking.
7. Verify that the fuel tank vent is operational.
8. Verify that fuel pressure is 2.75 to 3.75 Bar (39.9~54.4 psi).
9. Change the entire PFA.

Other

1. Turn the key to the ON position. Within 10 seconds, measure the voltage between the terminal at the ECR relay connection and the battery ground. Voltage should measure same as battery voltage.

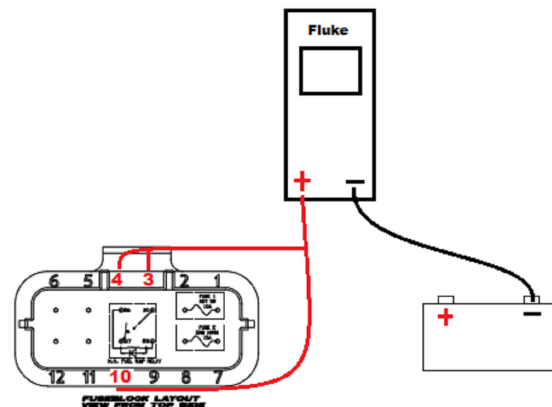

2. Replace the TBA (with ECM).
3. Tighten screws.
4. Replace the injector.
5. Verify the injector resistance is $12.0 \pm 0.6 \Omega$.
6. Verify that the injector O-ring is not damaged.
7. Replace the engine temperature sensor.
8. Replace the air cleaner.
9. Replace fuel.
10. Clean out or replace the fuel line.
11. Turn the key to the ON position. Within 10 seconds, measure the voltage between the terminals at Fuse #1, then terminals at the Fuse #2 connection and battery ground. Voltage should measure the same as the battery voltage.

FUEL SYSTEM

Read all of SAFETY and this section before attempting any procedure. Pay particular attention to Notices, Cautions, Warnings and Dangers.

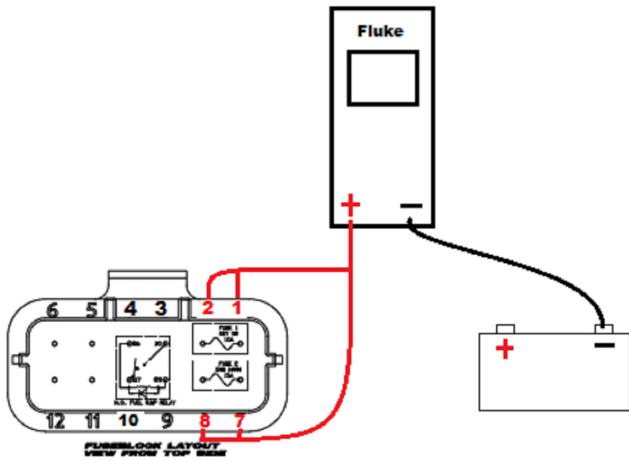

ELECTRICAL

CIRCUITS AND CONTROLS

The electrical system is a 12 volt negative ground system consisting of:

- Battery
- Starter/generator
- Voltage regulator
- Solenoid
- Magneto
- Fuse
- Key switch

⚠ WARNING *To decrease the risk of injury or death from accidental movement of the vehicle, all tests performed requiring the starter/generator or the engine to rotate must be performed with the vehicle lifted (see SAFETY section) or the neutral lock engaged (see GENERAL INFORMATION AND ROUTINE MAINTENANCE section).*

Follow the lifting procedure in the SAFETY section. Place wheel chocks in front and behind the front wheels. Check the stability of the vehicle on the jack stands before starting any repair procedure. Never work on a vehicle that is supported by a jack alone.

STARTER

When starting the engine, the field coils are in series with the armature and the starter/generator operates as a motor. This circuit is controlled by the key switch, fuse, accelerator limit switch and the solenoid. With the key in the ON position, battery current is available to the accelerator limit switch which remains open until the accelerator pedal is pressed. When the pedal is pressed, the plunger on the switch is released, the contacts close and the ignition circuit is energized. Battery current then energizes the solenoid which closes the contacts and energizes the starter circuit. The starter/generator now functions as a starter to start the engine.

GENERATOR

When the engine is running, the starter/generator functions as a generator. This is used for charging the battery and for the ignition system. Generated output is controlled by the voltage regulator at 14.25 - 14.75 V, without regard to engine speed. However, the charging current will vary depending on the condition of the battery. If it is fully charged, current is controlled at 3 to 5 amps.

WIRING

⚠ WARNING *Before performing any test of wiring components, disconnect the battery cables from the battery to decrease the risk of electrical shock or explosion (see procedure in SAFETY section).*

Electrical tests of the wiring for continuity may be made with a DVOM (Digital Volt Ohm Meter) available through the Service Parts Department (P/N 27481G01). Any DVOM may be used, however the controls, displays and features may vary depending on the make and model. Set the meter selector to the ohms scale and check continuity between each circuit component as indicated. Example: If a switch is open or if there is a break in the wiring, the meter will display a visual signal. If an analog meter is used it will read infinity (∞).

TESTING THE IGNITION CIRCUIT

NOTICE: *This section assumes the fuel system is functioning and the engine is receiving fuel.*

Tool List	Qty.
DVOM	1
Spark Plug (NGK BPR2ES).....	1
Spark Plug Tester	1

⚠ WARNING *To decrease the risk of personal injury, never operate the starter unless both spark plugs are installed or the ignition system is disabled. Fuel drawn into the cylinders will be expelled through the spark plug opening and could be ignited by the ignition system or another source, resulting in a fire.*

The engine incorporates a magneto type ignition system. There is no distributor.

The engine can be stopped by turning the key switch to the **OFF** position. When the accelerator pedal is released, the limit switch contacts open and the ignition circuit is de-energized.

ELECTRICAL

Read all of SAFETY and this section before attempting any procedure. Pay particular attention to Notices, Cautions, Warnings and Dangers.

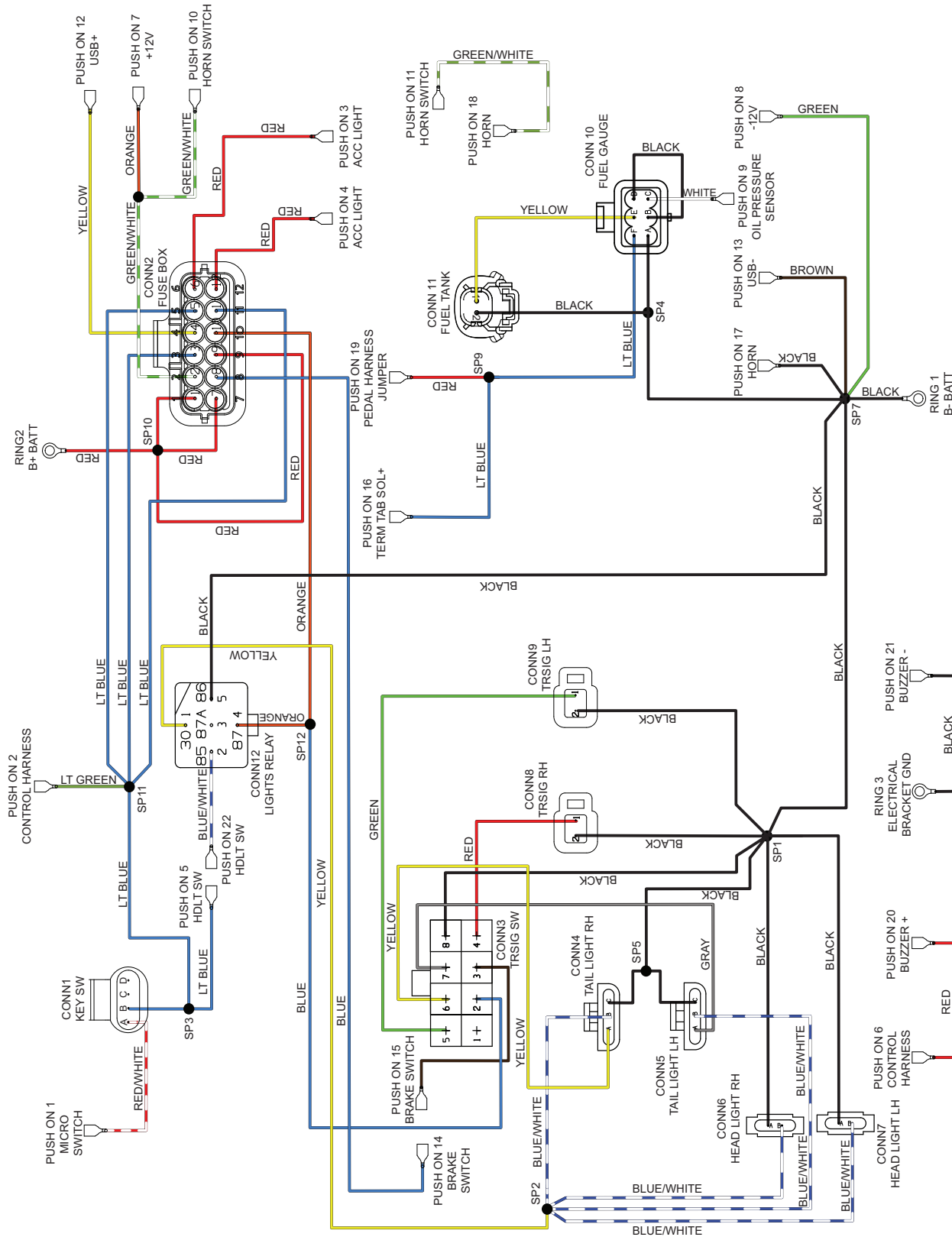

Fig. 1 Main Harness Wiring Diagram

Read all of SAFETY and this section before attempting any procedure. Pay particular attention to Notices, Cautions, Warnings and Dangers.

CAUTION Do not arc spark plug wire to ground. Connect to a known good spark plug and ground plug to a clean metal surface (muffler, cylinder, etc.). Permanent damage may be caused to the coil or igniter if the plug is not grounded properly.

If the engine will **not** run, but the starter will turn the engine, proceed as follows:

1. Check for loose terminals, wires and connections.
2. Check for an electrical discharge through the spark plug wire as follows:
 - a. Use a spark plug that is known good, and with a spark plug installed in the cylinder, place the spark plug on a clean grounded engine surface, (muffler, cylinder, etc.).
 - b. Turn the engine over with the starter.
 - c. Look for a blue electrical arc at the spark plug electrode.
4. If there is either a weak arc or no arc, try a new spark plug, then check the condition and the tightness of the spark plug wire. Check plug wires by substituting them with good ones.
5. Replace the plug if necessary. Gap the spark plug .028" - .030" (.71 - .76 mm) using a wire type spark plug gauge.

Testing the Magneto

Set the meter to the ohms scale and measure the resistance as shown in the following illustrations:

- A normal reading with the negative lead on A and the positive lead on B would be 2 - 18 K Ω .
- A normal reading with the negative lead on A and the positive lead on C would be 2 - 18 K Ω .
- A normal reading with the negative lead on B and the positive lead on A would be ∞ .
- A normal reading with the negative lead on B and the positive lead on A would be ∞ .
- A normal reading with the negative lead on C and the positive lead on A would be 2 - 18 K Ω .
- A normal reading with the negative lead on C and the positive lead on B would be 10 - 30 K Ω .

If readings obtained are out of the above ranges, replace the magneto.

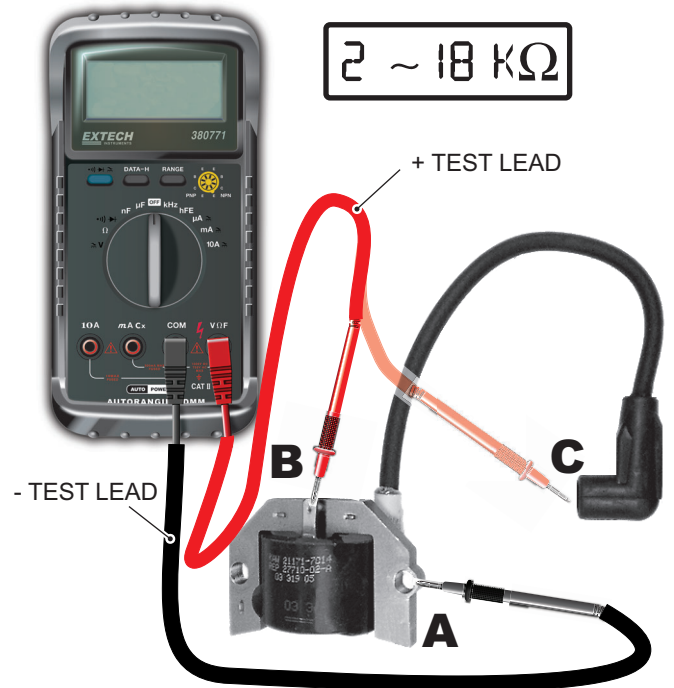

Fig. 2 Resistance Between A - B and A - C

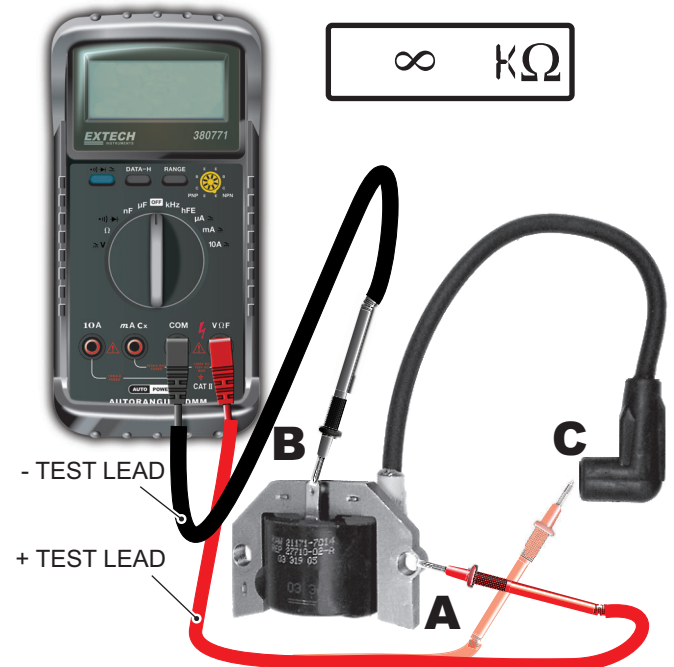

Fig. 3 Resistance Between B - A and B - C

ELECTRICAL

Read all of SAFETY and this section before attempting any procedure. Pay particular attention to Notices, Cautions, Warnings and Dangers.

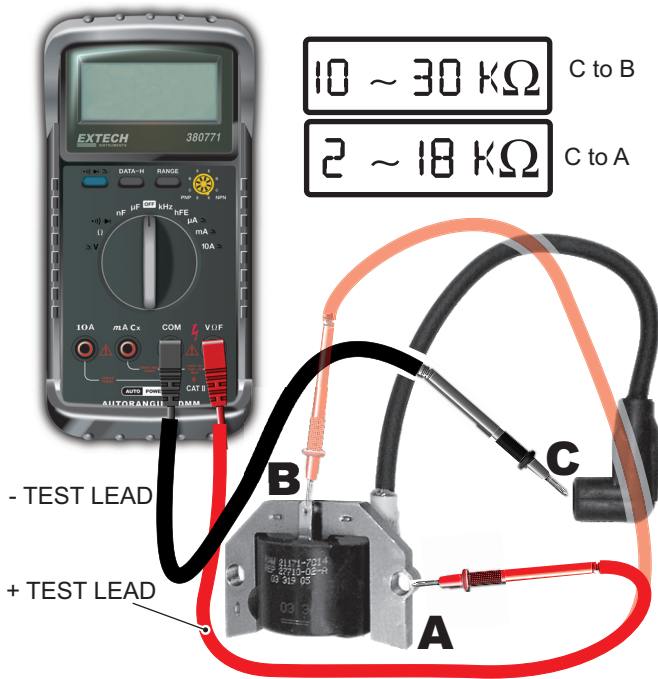

Fig. 4 Resistance Between C- B and C - A

7. Turn the key switch to **OFF**.
 - a. Place one probe of the DVOM (set to ohms scale) on the red wire at the solenoid. Place the other probe on the key switch terminal with the blue wire.
 - b. Press the accelerator and observe the DVOM. A reading of less than 2 Ω indicates a good limit switch. A reading of greater than 2 Ω indicates that the switch terminals should be checked. A reading of infinity, a visual signal (∞), indicates that the switch must be replaced. Connect the battery.
3. Check the starting solenoid operation. Turn the key switch to the **ON** position.
 - a. Place the DVOM (set to the appropriate DC volts scale) negative (-) probe on terminal A of the solenoid. Place the positive (+) probe on terminal B. The DVOM should indicate approximately 12 V.
 - b. Press the accelerator pedal. The DVOM will indicate "0" voltage if the solenoid contacts are closed.
 - c. If "0" voltage is not indicated while the accelerator pedal is pressed, replace the solenoid.

TESTING THE STARTING CIRCUIT

⚠ WARNING To decrease the risk of injury resulting from vehicle inadvertently starting, disconnect battery for steps 1 through 8 (see SAFETY section).

Tool List	Qty.
DVOM.....	1

If the engine does **not** start, proceed as follows:

1. Check the battery for a voltage reading which should be between 12.2 and 12.5 volts. Inspect for loose or dirty battery post connections.
2. Check for a blown in line fuse and replace if necessary.
3. Check for loose wires at all terminal connections.
4. Check the complete electrical system for correct circuitry (Ref. Fig. 1).
5. Inspect for worn insulation or bare wires touching the frame. Bare wires will cause a short circuit.
6. Check for continuity through the key switch. Set the DVOM to the ohms (Ω) scale. Detach wires. Place positive (+) probe on one terminal and negative (-) probe on the other terminal. The reading on the meter should be "0" Ω with the switch key in the **ON** position and a visual signal (∞) with the switch in the **OFF** position. If the meter does not register, replace the switch. Reconnect the wires.

TESTING THE CHARGING CIRCUIT

Tool List	Qty.
DVOM.....	1

⚠ WARNING To decrease the risk of injury resulting from vehicle inadvertently starting, the drive belt must be removed or entire vehicle must be lifted (see procedure in SAFETY section).

The charging circuit consists of a starter/generator, voltage regulator and battery. The solenoid must be functional in order to start the vehicle, but is not considered part of the charging circuit.

If the battery charge is inadequate (less than 11 VDC), proceed as follows:

1. Check the battery voltage and inspect for loose or corroded terminal posts and connections. Check electrolyte level.
2. Check charging circuit component terminals for proper, clean, tight connections.
3. Check for charging voltage as follows:
 - a. Raise the vehicle (see procedure in SAFETY section) so that both rear wheels are free to rotate.
 - b. With the engine off, measure the voltage at the battery's terminals by placing the negative (-) probe on the negative (-) post and the positive

Read all of SAFETY and this section before attempting any procedure. Pay particular attention to Notices, Cautions, Warnings and Dangers.

- (+) probe on the positive (+) post of the battery. Note the reading.
- c. Attach the DC voltmeter across the regulator's red and black leads.
- d. Start the engine and accelerate to governed speed.
- e. The meter should read higher than before starting the engine. In a reasonable amount of time, the reading should settle between 14 and 15 volts, indicating the regulator is functioning properly.
- f. If no increase over battery voltage is observed, there is a malfunction in the charging circuit.
- g. If the reading is **above** 15 volts, check to assure the wiring harness and generator field winding (green lead) is not grounded. If it is not, replace the regulator.
- h. If the reading is **below** 14 volts, disconnect the regulator's green field wire from the system har-

ness. Temporarily connect the green field wire to ground. If the voltage rises above its prior reading, replace the regulator.

- i. If the above procedures do not correct the problem, check for faults in the vehicles wiring harness and/or generator.

INSPECTION

1. Inspect the commutator for wear or damage.
2. Inspect the brush assembly for wear and damage to the brush holder insulators. Check the brushes for length, approximately 11/16" (17 mm) or to the line marked on the brush and signs of carbonization.
3. Inspect the armature for distortion or broken wires.
4. Inspect the field coil insulators and lead wire.
5. Check the bearings for free rotation and lack of end play on shaft. Replace if necessary.

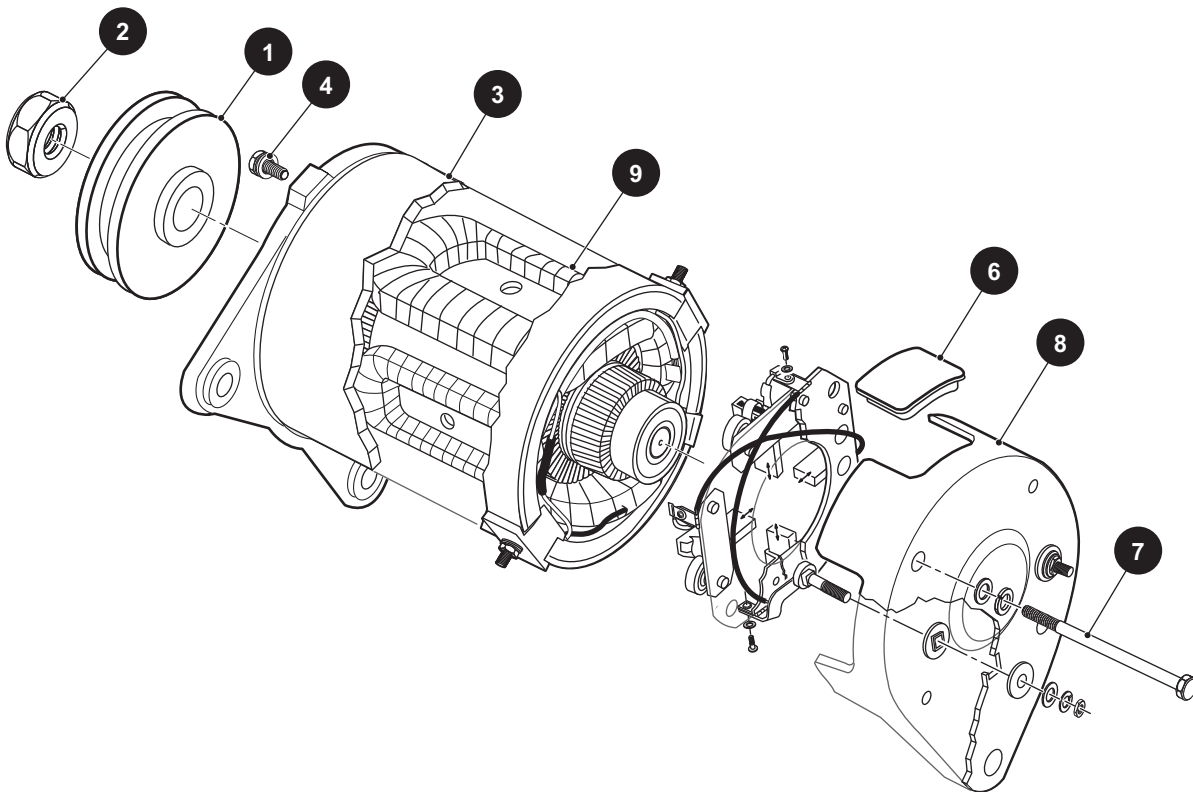

Fig. 5 Starter/Generator

ELECTRICAL

Read all of SAFETY and this section before attempting any procedure. Pay particular attention to Notices, Cautions, Warnings and Dangers.

STARTER/GENERATOR

Starter/Generator Removal

See ENGINE section.

Disassembly

Tool List

	Qty.
DVOM.....	1
Wrench, 24 mm	1
Wrench, 10 mm	1
Wrench, 6 mm	1
Wrench, 5 mm	1
Socket, 10 mm.....	1
Phillips Screwdriver	1
Two Jaw Puller	1
Straight Blade Screwdriver	1
Ratchet	1
Torque Wrench, ft. lbs.....	1
Torque Wrench, in. lbs.....	1
Clean Cloth.....	1

NOTICE: In general, starter/generator service is best performed by trained motor technicians who have the knowledge and equipment to overhaul the unit. Some checks and repairs however, can be accomplished by a skilled mechanic. Make your own evaluation of the equipment and skills available before starting disassembly.

Hold the pulley (1) and remove the pulley nut (2). Remove the pulley, screws (4) and front cover (3) (Ref. Fig. 5).

Remove the brush covers (6) by prying out with a screwdriver. Pull up on the brush springs and move to the side of brushes, slide the brushes out approximately 1/4" (6 mm) (Ref. Fig. 5). Remove the through bolts (7) and the rear cover (8). Remove the frame and field coils (9). Remove the 5mm screws from the brush holder and 6 mm nuts from A1 and A2 terminals. Remove the brush holder. If the bearing needs to be replaced, use an automotive style two jaw puller to remove the bearing from armature (Ref. Fig. 6).

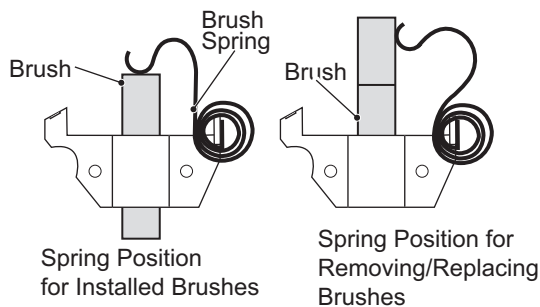

Fig. 6 Starter/Generator Brush Removal

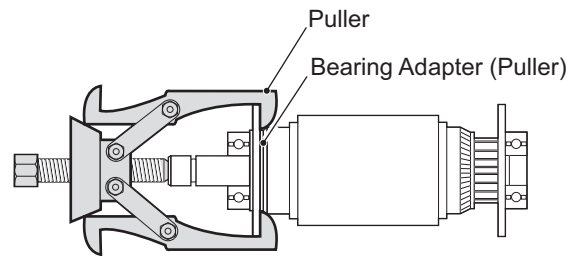

Fig. 7 Bearing Removal

Repair and Replacement

1. Clean commutator with a soft, clean cloth.
 2. Replace any damaged or cracked brush holders or brushes worn to less than 11/16" (17mm) in length or to the line marked on the brush.
 3. Test the insulation between the core and the commutator segments and shaft with a circuit tester. If continuity is indicated, the insulation is defective and the armature must be replaced.
 4. With the brushes removed, using a DVOM, check the field coils for continuity between F1 and F2 and DF and F1. If an open circuit exists, replace the field coils. Check for continuity between all four terminals and the frame (outer shell). If continuity is indicated, the field coils are grounded against the frame and the field coils must be replaced.
 5. Clean all parts to be reinstalled. Installation is reverse order of removal. Tighten bolts and nuts to the following values:
 - 4 mm - torque to 15 - 21 in. lbs. (1.6 - 2.3 Nm)
 - 5 mm - torque to 30 - 43 in. lbs. (3.3 - 4.8 Nm)
 - 6 mm - torque to 52 - 74 in. lbs. (6.7 - 8.3 Nm)
 - 14 mm - torque to 33 - 40 in. lbs. (3.7 - 4.5 Nm)
- Tighten **terminal nuts** to the following torques:
- F1 - F2 - torque to 43 - 52 in. lbs. (4.8 - 6.7 Nm)
 - DF - torque to 26 - 35 in. lbs. (2.9 - 3.9 Nm)

VOLTAGE TEST FOR BATTERY

Battery voltage can be checked using a voltmeter. Attach the negative (-) lead of the DVOM to the ground terminal of the battery. The positive (+) lead is then attached to the positive battery terminal. The voltage reading obtained should be 12 volts or above. If the reading is below 12 volts, the battery requires either charging or replacement.

Read all of SAFETY and this section before attempting any procedure. Pay particular attention to Notices, Cautions, Warnings and Dangers.

⚠ WARNING Hydrogen gas formed during battery charging is explosive.

Avoid any electrical spark or open flame near battery.

NOTICE: If the temperature of the battery or the ambient temperature is below 60° F (15.55° C), the capacity of the battery will be less. It will require more time to charge.

Voltage on a cold battery increases faster, therefore decreases the charging rate.

Fully charge a new battery or batteries that have been in storage before testing or installing in vehicle.

⚠ CAUTION Do not overcharge battery.

STORAGE OF BATTERY

A battery that is removed from service for storage must be cared for as follows:

For battery removal, see Battery Removal in SAFETY section. Charge fully. Cover terminals with petroleum jelly to decrease the risk of oxidation (use commercially available battery protector when installed in vehicle). Store in a cool place not below 32° F (0° C) or above 80° F (27° C) battery should be charged every 30 days using a 2 amp trickle charger.

DVOM (DIGITAL VOLT OHM METER)

The DVOM shown (Ref. Fig. 8) is representative only. The actual model may vary depending on availability, and is available through the Service Parts Department as P/N 27481-G01. For the purpose of this section, the red probe (+) and black probe (-) are used. Any DVOM may be used, however the controls, displays, accuracy and features may vary depending on the make and model. Always follow the meter manufacturer's recommendations and instructions for the use and care of the meter.



Fig. 8 DVOM

FAULT TESTING

Knowledge of use of wiring diagrams and a Digital Volt Ohm Meter (DVOM) is necessary to effectively determine fault within the circuits that include the horn, lighting, brake/turn signals and gauges.

The wiring diagram shows the path followed by a voltage or signal from its origination point to its destination. Each wire is indicated by color and is divided into the main harness and the dash harness.

Knowledge of simple logic fault testing will decrease the number of steps required to isolate the problem.

Example 1: If the vehicle does not start and none of the lights function (or burn dimly), test the battery before trying to determine fault within the lighting circuit.

Example 2: If a problem occurs in the lighting circuit that causes only one of the headlights to fail, it is not necessary to check the battery wiring or the fuse since voltage is present. Check the headlight that is not operating. If power is found at the connector and the ground wiring is satisfactory, it is a burned out bulb or a poor contact between the connectors and the headlight.

If power is not present but the other headlight functions, a wiring problem is indicated between the two headlights.

In some cases where battery voltage is expected, the easiest way to test the circuit is to set the DVOM to DC volts and put the negative (-) probe on the negative battery terminal. Move the positive (+) probe to each wire terminal starting at the battery and moving out to the device that is not working. Check both sides of all switches and

ELECTRICAL

Read all of SAFETY and this section before attempting any procedure. Pay particular attention to Notices, Cautions, Warnings and Dangers.

fuses.

When no battery voltage is found, the problem is between the point where no voltage is detected, and the last place that voltage was detected. In circuits where no voltage is expected, the same procedure can be used except that the DVOM is set to continuity. Place the negative (-) probe on a wire terminal at the beginning of the circuit and move toward the device that is not working with the positive (+) probe. When continuity is no longer indicated, a failed conductor or device is indicated.

POWER SUPPLY

Tool List	Qty.
DVOM.....	1

1. Check for loose or bare wires:

Check for loose wires at each terminal connection and for worn insulation or bare wires touching the frame. **Bare wires may cause a short circuit.**

NOTICE: If any DVOM readings indicate a faulty wire, it is recommended that the condition of the terminals and wire junction be examined. A faulty wire must be replaced with one of the same gauge and color, wired between the correct components, and wire tied to the harness bundle. The faulty wire should be cut back close to the harness and the ends protected with vinyl electrical tape.

2. Check battery condition:

Check for adequate battery volts (nominal 12 VDC) by setting DVOM to 30 VDC range and place the red probe (+) on the battery post with the green wire attached. Place the black probe (-) on the battery post with the black wire attached. A reading of 11 VDC or greater indicates adequate battery condition. No reading indicates (a) a poor connection between the probes and the battery terminals; (b) a faulty DVOM. A voltage reading below 11 volts indicates poor battery condition and the vehicle should be recharged before proceeding with the test.

NOTICE: Due to the resistance of the wires involved within the harness, voltage readings may be somewhat lower than battery voltage. A reading of 1 volt below battery voltage is acceptable.

3. Check power wire:

Firmly attach the black probe (-) to the battery post with the black wire attached and the red probe (+) to the green wire terminal at the fuse block. A reading of battery voltage indicates that the power wire is in good condition.

NOTICE: The power wire supplies power to the entire fuse block.

4. Check fuse:

Place the red probe (+) to each wire terminal on the fuse block. A reading of battery voltage indicates that the fuse

is in good condition. No reading indicates a faulty fuse; replace with a good 15 amp fuse.

ACCESSORY WIRING

After determining that there is power to the fuse panel, and the fuse is good, continue checking the circuit using the procedures previously used to check the power supply, i.e. loose or rusted connections, bare wires, continuity of the wiring from terminal to terminal, operating condition of switch, etc.

Use the wiring diagram (Ref. Fig. 1) to check correct wiring and wire routing. If there is power at the fuse end of the wire, there must also be power at the other end of the wire at the switch or electrical accessory, and eventually at the ground connection. Electricity must flow from the fuse panel through the full length of the circuit to the ground connection. Any interruption of electrical flow must be corrected, whether by repairing or replacing the wire, the switch or accessory.

LIGHT BULB REPLACEMENT

CAUTION To decrease the risk of premature bulb failure, do not allow your fingers to contact new bulbs. Use clean, dry paper or paper towels to touch the glass part of the bulb.

Headlight Bulb Replacement

Tool List	Qty.
Wrench, 10 mm.....	1

Remove the front grille assembly (3), from the cowl by removing the self threading nut (8).

NOTICE: The following procedure is applicable for vehicles with halogen headlights.

Always handle halogen light bulbs with a clean, soft cloth. Oil from fingers will shorten the life of a halogen bulb.

For vehicles equipped with halogen headlights mounted in the cowl, locate bulb socket (1) on backside of light and turn bulb socket a quarter turn counterclockwise to unlock and pull out bulb and socket (Ref. Fig. 5).

Insert new bulb and rotate socket (1) a quarter turn clockwise to secure.

NOTICE: Following procedure is applicable for vehicles with LED headlights.

LED headlights are designed for longevity and do not fail often. In case of failure, however, the complete headlight assembly must be replaced. Replacement for the single LED headlight failed is not possible. Refer to Service Parts Manual for the part number of the LED headlight.

To replace the LED headlight assembly (5), locate and

Read all of SAFETY and this section before attempting any procedure. Pay particular attention to Notices, Cautions, Warnings and Dangers.

remove the nuts securing the headlight assembly (5) and the front grille assembly (3).

Remove the nuts allowing the LED headlight assembly (5) to be removed from the outside of the cowl.

Disconnect the wires.

Replace with a new LED headlight assembly and install headlight assembly in the reverse order of removal.

Taillight Replacement

For vehicles Manufactured Before July 25, 2021.

To replace the taillight bulb or the brake light bulb, roll the rubber bezel from around the edge of the taillight and

remove lens (Ref. Fig. 9). Install replacement bulb and replace lens.

Headlight/taillight bulbs and fuses are available from a local Distributor, an authorized Branch or the Service Parts Department.

For Vehicles Manufactured After July 25, 2021.

To replace LED taillight, remove taillight from the grommet (12). Remove the grommet and disconnect the wires. Replace with a new LED taillight (13) and install the taillight in the reverse order of removal.

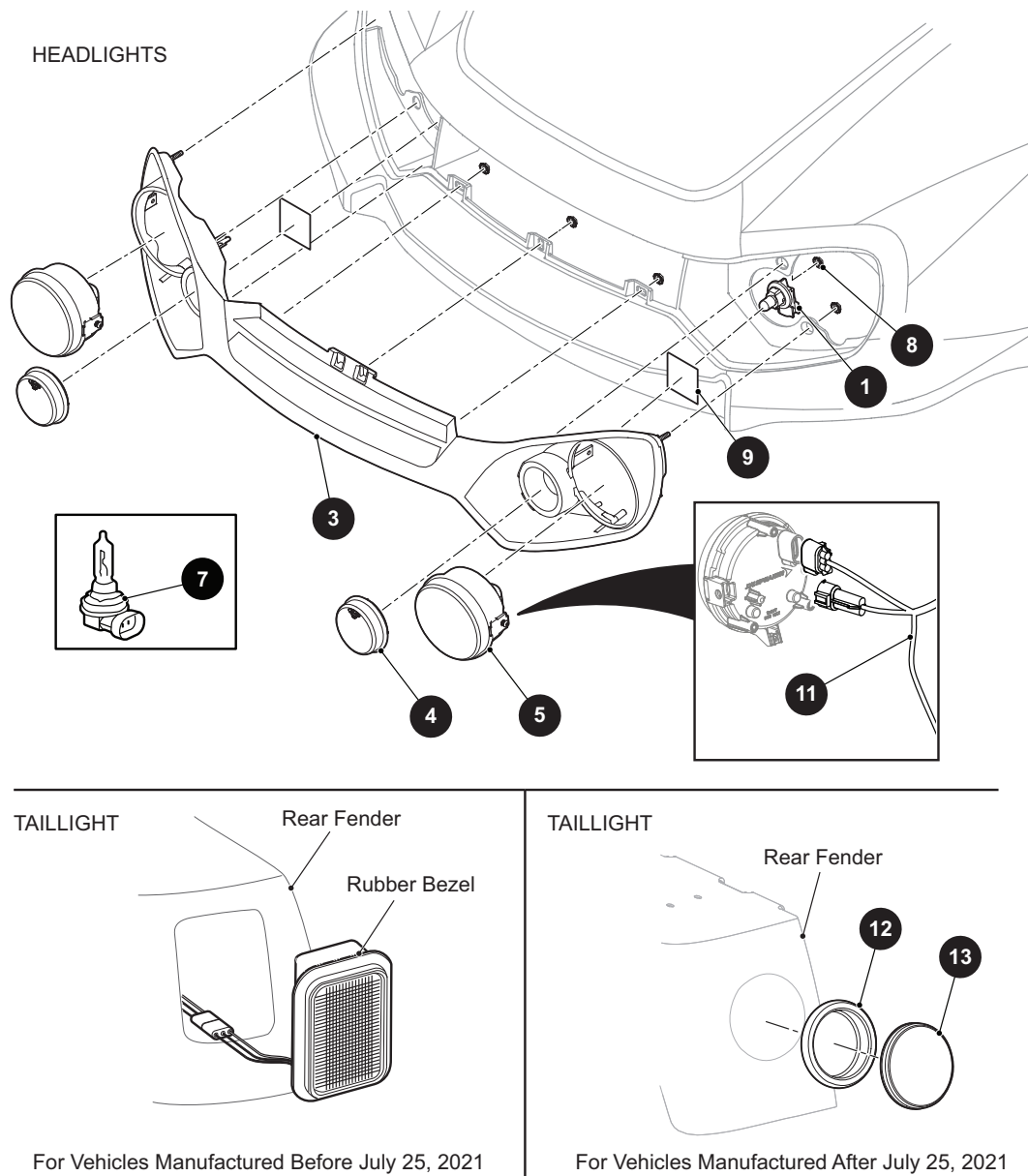

Fig. 9 Headlights And Taillights

ELECTRICAL

Read all of SAFETY and this section before attempting any procedure. Pay particular attention to Notices, Cautions, Warnings and Dangers.

FAULT TESTING

General

To effectively troubleshoot the electrical circuits that include the headlights, brake light and the information display, etc, the technician must be able to use the wiring diagram and a Digital Voltage Ohm Meter (DVOM).

Voltmeter

⚠ WARNING Before performing any test of wiring components, disconnect the battery cables from the battery posts to prevent electrical shock or explosion. See Battery Removal on page 9.

Electrical tests of the wiring for continuity may be made with a DVOM (Digital Volt Ohm Meter). Always follow the meter manufacturer's recommendations and instructions for the use and care of the meter. For the purpose of this section, the red probe (+) and black probe (-) are used. Set the meter selector to the ohms scale and check continuity between each circuit component.

Continuity Check

⚠ WARNING To prevent possible injury or death resulting from a battery explosion, use an insulated wrench and remove the negative (-) cable from the battery to disconnect electrical power to vehicle.

Turn the key switch to the OFF position. Place the direction selector in the P (park) position before disconnecting power by removing the negative (-) connection to the battery.

To check for continuity, set the DVOM to the $K\Omega$ setting and select 'Continuity'. The meter will give an audible signal when it detects continuity. If the meter does not have a continuity setting, set it to $K\Omega$, the meter will indicate "0" when it detects continuity.

Testing a Switch for Continuity

Place one probe on one contact of the switch, place the second probe on the second terminal of the switch.

Actuating a normally open (NO) switch will cause the DVOM to show "0" or give an audible indication when the switch is operated. A normally closed (NC) switch will cause the meter to show "0" or give an audible indication when the probes are attached without activating switch. The audible indicator will stop and the meter display will indicate a value greater than "0" when the switch is activated.

The change in display or audible indicator demonstrates that the switch is functioning.

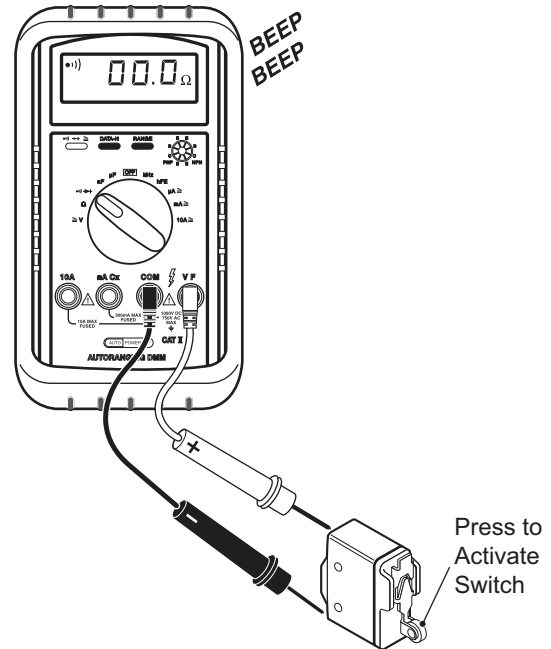

Fig. 1 Continuity Check of Switch

Testing the Ignition System

Locate the spark plugs and remove plug boot.

Use a spark plug tester between the plug boot and the spark plug. Turn the key to engage the starter. A steady spark should be observed. If spark is not adequate, inspect the coil and the spark plug wire.

Testing Fuses

Check all the fuses to make sure that components are properly powered.

If the fuse appears to be blown, replace the fuse.

FAULT TESTING

Read all of SAFETY and this section before attempting any procedure. Pay particular attention to Notices, Cautions, Warnings and Dangers.

POWERTRAIN PERFORMANCE

CONDITION	POSSIBLE CAUSE	CORRECTION
STARTER DOES NOT TURN	Weak or bad battery	Charge or replace as necessary
	Terminals are loose or corroded	Clean and tighten
	Poor wiring connections	Repair or replace wire and/or connections
	Faulty ignition switch	Repair or replace wire switch, and/or connections
	Blown fuses	Investigate cause and replace fuses
	Solenoid faulty	If no audible 'click' is heard, check power and ground. Replace solenoid if power and ground is good
	Starter terminals are loose or corroded	Tighten or clean
	Leads are broken or faulty ground	Repair or replace
	Bad relay	If no audible click is heard, replace engine start relay
STARTER TURNS SLOWLY	Terminals are loose or corroded	Re-tighten or clean
	Weak battery	Charge battery
	Leads are nearly broken or connections are faulty	Check for any defect of leads at bend or joint. Replace leads or repair connections
	Mechanical problem inside starter	Replace starter.
	Internal engine damage	Inspect and repair
	Crankcase over filled with oil	Drain and fill to recommended level with approved oil
STARTER ROTATES BUT VEHICLE WILL NOT START OR HARD TO START	Weak battery	Recharge or replace as necessary
	Corroded or loose battery connections	Clean and tighten battery connections. Apply a coat of battery protectorate to terminals
	Check for adequate fuel level	Fill with correct grade gasoline. See GENERAL SPECIFICATIONS.
	No spark at spark plugs. Broken or disconnected spark plug wiring	Check and replace if required. See GENERAL SPECIFICATIONS.
	Spark plugs fouled	Clean or replace
	Incorrect spark plug	Check that spark plugs are the correct type. See GENERAL SPECIFICATIONS.
	Fuel pump faulty	Repair or replace
	Fuel line clogged or clamp loose	Clean or replace if required
	Cracked or broken fuel line	Replace with new hose
	Clogged fuel filter	Check and replace if required
	Engine flooded	Clean/or replace spark plugs
	Engine fuel starved	Check fuel line
	Clogged air filter	Wash or replace as required
	Plugged muffler or pipe	Repair or replace
POOR LOW SPEED PERFORMANCE	Plugged gas tank vent	Clean or repair
	Fuel pump faulty	Replace
	Insufficient fuel level	Add fuel
	Spark plug fouled	Clean or replace

Fig. 2 Powertrain Performance Troubleshooting

FAULT TESTING

Read all of SAFETY and this section before attempting any procedure. Pay particular attention to Notices, Cautions, Warnings and Dangers.

CONDITION	POSSIBLE CAUSE	CORRECTION
POOR MIDRANGE OR HIGH SPEED PERFORMANCE	Spark plug fouled	Clean or replace
	Dirty air filter	Clean or replace
	Brake(s) dragging	Perform brake maintenance
ENGINE OVERHEATING	Damaged or plugged muffler	Clean, repair or replace
	Inadequate oil supply	Check oil system, inspect oil pump, change oil, fill to correct level
	Cooling fan clogged	Clean
REPEATED SPARK PLUG FOULING	Wrong spark plug type	Replace with correct spark plug. See GENERAL SPECIFICATIONS.
	Wrong spark plug gap	Replace with correct spark plug. See GENERAL SPECIFICATIONS.
	Faulty ignition system	Check and repair if required
	Poor quality gasoline	Use correct fuel, check bulk storage tank for proper storage and handling. See GENERAL SPECIFICATIONS.
	Air leak allowing dirt to enter system	Repair or replace air intake hose
EXCESSIVE EXHAUST SMOKE	Wrong oil weight	Replace with recommended oil. See GENERAL SPECIFICATIONS.
	Dirty oil	Replace. See GENERAL SPECIFICATIONS.
	Crankcase overfilled with oil	Drain and fill to recommended level. See GENERAL SPECIFICATIONS.
	Piston rings worn or broken	Replace
	Valves worn	Replace
	Valve seals or valve guides worn	Replace
BACKFIRING	Faulty plug wires	Replace
	Faulty ignition system	Check and repair if required
ERRATIC, SURGING, OR SUDDEN CHANGE IN GOVERNED SPEED	Governor bracket spring dragging	Clean and/or oil
	Problem with adjustment of accelerator, governor linkage	Adjust
	Bent governor arm	Repair or replace
	Bent governor shaft	Replace
	Governor failure within the rear axle	Repair

Fig. 2 Powertrain Performance Troubleshooting (Continued)

FAULT TESTING

Read all of SAFETY and this section before attempting any procedure. Pay particular attention to Notices, Cautions, Warnings and Dangers.

STARTER FAULT TESTING

CONDITION	POSSIBLE CAUSE	CORRECTION
STARTER IS NOISY	Bolts are loose	Tighten to correct torque
	Starter has foreign matter inside	Clean starter interior
	Bearings are faulty	Replace
	Bearings contain foreign matter	Replace

Fig. 3 Starter/Generator Troubleshooting

SUSPENSION AND STEERING FAULT TESTING

CONDITION	POSSIBLE CAUSE	CORRECTION
UNEVEN TIRE WEAR	Incorrect tire pressure	Inflate to recommended pressure. See GENERAL SPECIFICATION.
	Improper alignment (Incorrect toe in)	Align front tires
PLAY IN STEERING	Steering wheel loose	Inspect splines - replace steering wheel if required; Tighten steering wheel nut
	Steering components worn	Replace
	Loose wheel bearings	Adjust or replace
VIBRATION	Steering components worn	Replace
	Loose wheel bearings	Adjust or replace
	Out of round tires, wheels, or brake drums	Inspect and replace if out of round
STEERING PULLS TO ONE SIDE	Incorrect tire pressure	Inflate to recommended pressure
	Dragging wheel brakes	Brake system
	Suspension component failure	Repair
	Alignment incorrect	Align

Fig. 4 Suspension and Steering Troubleshooting

FAULT TESTING

Read all of SAFETY and this section before attempting any procedure. Pay particular attention to Notices, Cautions, Warnings and Dangers.

FAULT TESTING

Read all of SAFETY and this section before attempting any procedure. Pay particular attention to Notices, Cautions, Warnings and Dangers.

Read all of SAFETY and this section before attempting any procedure. Pay particular attention to Notices, Cautions, Warnings and Dangers.

GENERAL SPECIFICATIONS

SPECIFICATIONS CHART

Item	Specification
Overall Length	119.0 in (302 cm)
Overall Width	51.5 in (131 cm)
Overall Height (No Canopy)	53.0 in (135 cm) (Top of steering wheel)
Overall Height (With Canopy)	77.0 in (196 cm)
Wheel Base	77.5 in (197 cm)
Front Wheel Track	44 in (112 cm)
Rear Wheel Track	46 in (117 cm)
Ground Clearance (at Differential)	7.0 in (18 cm)
Turning Radius	11.8 ft (3.6 m)
Cargo Box Width (inside)	44.0 in (112 cm)
Cargo Box Length (inside)	39.0 in (99 cm)
Cargo Box Depth (inside)	12 in (31 cm)
Cargo Box Capacity	12 ft ³ (0.34 m ³)
Cargo Box Material	Roto-molded Polyethylene
Engine	Walbro 4-Cycle 24.5 in ³ (401 cc)
Valvetrain	Single Cylinder OHV
Horsepower (kW)	13.5 hp (10.1 kW) Exceeds SAE J1940 Standard
Cooling System	Air Cooled
Balancer	Internal Counter Rotating Balance Shaft
Ignition	Electronic Inductive Spark / Magneto
Electrical System	Starter / Generator. Solid State Regulator
Battery	12-Volt Maintenance-Free (525 CCA, 85 minute reserve)
Key or Pedal Start	Pedal
Air Cleaner	Replaceable Dry Cartridge
Lubrication	Pressurized Oil System
Oil Filter	Spin-On
Fuel System	Closed-loop electronic fuel injection
Max Fuel Volume	6.65 Gallon (25 L)
Fuel Pump Operating Pressure	43.5 psi (3 bar)
Drivetrain	Automatic, Continuously Variable Transmission (CVT)
Transaxle	Differential with helical gears
Gear Selection	Forward - Reverse
Rear Axle Ratio	11.47:1 (Forward) 14.35:1 (Reverse)
Seating Capacity	2-Person
Dry Weight	1052 lb (477 kg)(without battery)
Curb Weight	1092 lb (495 kg)
Bed Load Capacity	500 lb (227 kg)

GENERAL SPECIFICATIONS

Read all of SAFETY and this section before attempting any procedure. Pay particular attention to Notices, Cautions, Warnings and Dangers.

Vehicle Load Capacity	900 lb (408 kg)
Outside Clearance Circle	23.5 ft (7.2 m)
Speed (Level Ground)	16.5 mph \pm 0.5 mph (26.58 kph \pm 0.80 kph)
Maximum Drawbar	500 lbs (2225 N)
Towing Capacity	1200 lbs (544 kg) max load
Steering	Self-compensating reduction rack and pinion
Front Suspension	Leaf springs with hydraulic shock absorbers
Rear Suspension	Leaf springs with hydraulic shock absorbers
Brakes	Dual rear wheel mechanical self-adjusting drum
Parking Brake	Self-compensating, single point engagement
Front and Rear Tires	Desert Eagle 23 x 10 - 12 (4 ply rated)
Frame	Welded steel with DuraShield™ powder coat
Front Body and Finish	Injection Molded TPO
Rear Body and Finish	Injection Molded TPO
Noise	Sound pressure; continued A-weighted equal to or less than 74 db(A)
Vibration, WBV	Highest RMS value of weighted acceleration is less than 2.5 m/s ² .
Vibration, HAV	Highest RMS value of weighted acceleration is less than 2.5 m/s ² .
	The uncertainty of measurement is 0.54 m/s ² .
	Measurement methods were applied per the ISO 2631 and ISO 5349 standards under conditions of typical vehicle surfaces.

Some items shown may be optional equipment

GENERAL SPECIFICATIONS

Read all of SAFETY and this section before attempting any procedure. Pay particular attention to Notices, Cautions, Warnings and Dangers.

GENERAL SPECIFICATIONS

Read all of SAFETY and this section before attempting any procedure. Pay particular attention to Notices, Cautions, Warnings and Dangers.

GENERAL SPECIFICATIONS

Read all of SAFETY and this section before attempting any procedure. Pay particular attention to Notices, Cautions, Warnings and Dangers.

GENERAL SPECIFICATIONS

Read all of SAFETY and this section before attempting any procedure. Pay particular attention to Notices, Cautions, Warnings and Dangers.

Read all of SAFETY and this section before attempting any procedure. Pay particular attention to Notices, Cautions, Warnings and Dangers.

SCHEDULED MAINTENANCE

Perform all services at the maintenance interval reached first.

S –Indicates operations that need to be performed on vehicles subjected to severe use.

E –Indicates emission-related services (Failure to do this maintenance will not void the emissions warranty but may affect emissions).

D –Indicates services that must be performed by an authorized dealer.

Item	Interval (perform at interval that comes first)		Remarks
	Hours	Calendar	
Steering	Pre-ride		Check for smooth and free operation.
Front suspension	Pre-ride		Inspect. Check for leaks and loose or missing hardware.
Rear suspension	Pre-ride		Inspect. Check for leaks and loose or missing hardware.
Tires	Pre-ride		Check condition and pressure.
Wheel lug nuts	Pre-ride		Check for loose or missing.
Accelerator	Pre-ride		Check for smooth operation.
Brake system	Pre-ride		Check for proper operation.
Frame hardware	Pre-ride		Check for loose or missing.
Fuel and engine oil level	Pre-ride		Check for correct level.
Air filter	Pre-ride		Inspect. Clean or replace as needed.
Headlights and taillights	Pre-ride		Check operation. Replace bulbs as needed.
Reverse warning alarm	Pre-ride		Check operation.
Switches	Pre-ride		Check operation.
Fluid leakages	Pre-ride		Inspect entire vehicle for leaks
CVT belt	Pre-ride		Check condition.
Engine oil and filter	Initial Service		Replace oil and filter at first 50 hours of operation.
Starter/generator belt	Initial Service		Check between first 15 and 20 hours.
Wheels	Weekly		Check condition of rims, missing or loose lug nuts.
S E Air filter	Weekly		Inspect. Replace as needed.
S Cooling fins	Weekly		Check for build-up of dirt inside blower housing and fins; clean as necessary.
S Engine oil	Weekly		Check level; add as necessary.
Starter/generator belt	Weekly		Check condition.
S Brake shoes	10	Monthly	Inspect. Replace as needed.
Parking brake	20	Monthly	Conduct brake performance test; adjust as necessary
Wiring	20	Monthly	Inspect for loose connections, broken or missing insulation.
Direction selector	20	Monthly	Inspect attachment and mechanism; adjust as necessary.
Steering	20	Monthly	Check for excess play, loose or missing hardware.
S Tie rods	20	Monthly	Check for excess play, bent rods, loose or missing hardware.
Engine	20	Monthly	Check for unusual noise, vibration, acceleration, oil leaks.
Rear axle	20	Monthly	Check for leakage; add oil as required.
S General lubrication	50	3 Months	Lubricate all fittings, pivots, cables, etc. where required.
Throttle/governor linkage	50	3 Months	Check operation and governed speed.

SCHEDULED MAINTENANCE

Read all of SAFETY and this section before attempting any procedure. Pay particular attention to Notices, Cautions, Warnings and Dangers.

Item		Interval (perform at interval that comes first)		Remarks
		Hours	Calendar	
E	Fuel system	50	3 Months	Check for leakage at tank, cap, lines, filters, pump, fuel rail.
	Front axle	50	3 Months	Check for damage, loose or missing hardware.
	Parking brake	50	3 Months	Inspect linkage rods, latch arm, catch bracket. Lubricate with light oil (Do not lubricate cables or brake latch).
S	Engine electrical system	50	3 Months	Check coil/spark plug wires for cracks or loose connections.
S	Rear suspension	50	3 Months	Inspect shocks for leaks, worn bushings, loose or missing hardware.
S	Front suspension	50	3 Months	Inspect strut for leaks. Check hubs and kingpins, for excessive play, worn bushings, loose or missing hardware.
	Front wheel alignment	50	3 Months	Inspect for unusual tire wear; align if necessary.
S	Battery	125	6 Months	Inspect terminals. Clean as needed.
	King pins	125	6 Months	Check for excessive play and tightness of retaining nuts.
	Rear axle	125	6 Months	Check for unusual noise, loose or missing hardware.
S E	Air filter	125	6 Months	Inspect; clean as necessary.
	CVT belt	125	6 Months	Inspect for cracks, fraying and excessive wear.
	Direction selector	125	6 Months	Check for wear and smooth movement; lubricate shaft with light oil if necessary.
	Steering	125	6 Months	Inspect bellows and pinion seal for damage and leakage.
	Rack end ball joint	125	6 Months	Check for noise and loose or missing hardware.
S	Air Filter	250	Yearly	Replace.
S	Oil filter	250	Yearly	Replace (with oil change).
S	Engine oil	250	Yearly	Replace. See for type and capacity.
S	Rear axle	250-300	Yearly	Check fluid level; add if required.
S	Front wheel bearings	250-300	Yearly	Check and adjust as necessary.
S	Brakes	250-300	Yearly	Clean and adjust. Check brake shoe linings; replace if necessary.
S	Muffler/exhaust system	250-300	Yearly	Check hardware. Inspect for leaks at head and muffler gaskets.
	Valves - intake/exhaust	250-300	Yearly	Check cold.
S E	Spark plug	250	Yearly	Replace and gap new.
	Cylinder head and piston	500	5 years	Remove carbon.
	Cylinder head and piston	500	5 years	Check valve seats for carbon buildup; clean if necessary.
	Rear axle	500	5 years	Replace fluid.

SCHEDULED MAINTENANCE

Read all of SAFETY and this section before attempting any procedure. Pay particular attention to Notices, Cautions, Warnings and Dangers.

RECOMMENDED LUBRICANTS AND FLUIDS

Check and lubricate all components at the intervals shown in the *SCHEDULED MAINTENANCE* beginning on page 137.

Item	Capacity	Lubricants/Fluids		Notes
Engine oil	1.3 qt. (1.25 L)	10W-30	Light duty use engines	
		10W-30	Heavy duty use in air temperatures below 40° F (4° C)	
		10W-40	Heavy duty use in air temperatures above 40° F (4° C) after 100 hour break-in period	
Fuel	5.96 Gallon (22.6 L)	Unleaded; 87 octane min 10% ethanol content max.		
Rear axle oil	51 oz. (1.5 L)	MOBIL 424		
Grease fittings		Universal joint grease or equivalent		Do not exceed 3 pumps of grease in each fitting.

REPLACEMENT OF MAINTENANCE ITEMS

These items or their equivalents can be purchased through an authorized dealer or any other qualified source.

Item	Part Number
Oil Filter	607454
Air Filter	28463G01
Spark Plug (NGK BPR2ES)	607462
Starter/Generator Belt	630587
Clutch Belt	618630
15A Fuse	636455G13
10A Fuse	636455G12
Fuel Pump Relay	663593
Headlight Bulb	74004G02
Turn Signal Bulb	676687
Taillight Bulb	604311

SCHEDULED MAINTENANCE

Read all of SAFETY and this section before attempting any procedure. Pay particular attention to Notices, Cautions, Warnings and Dangers.

Notes:

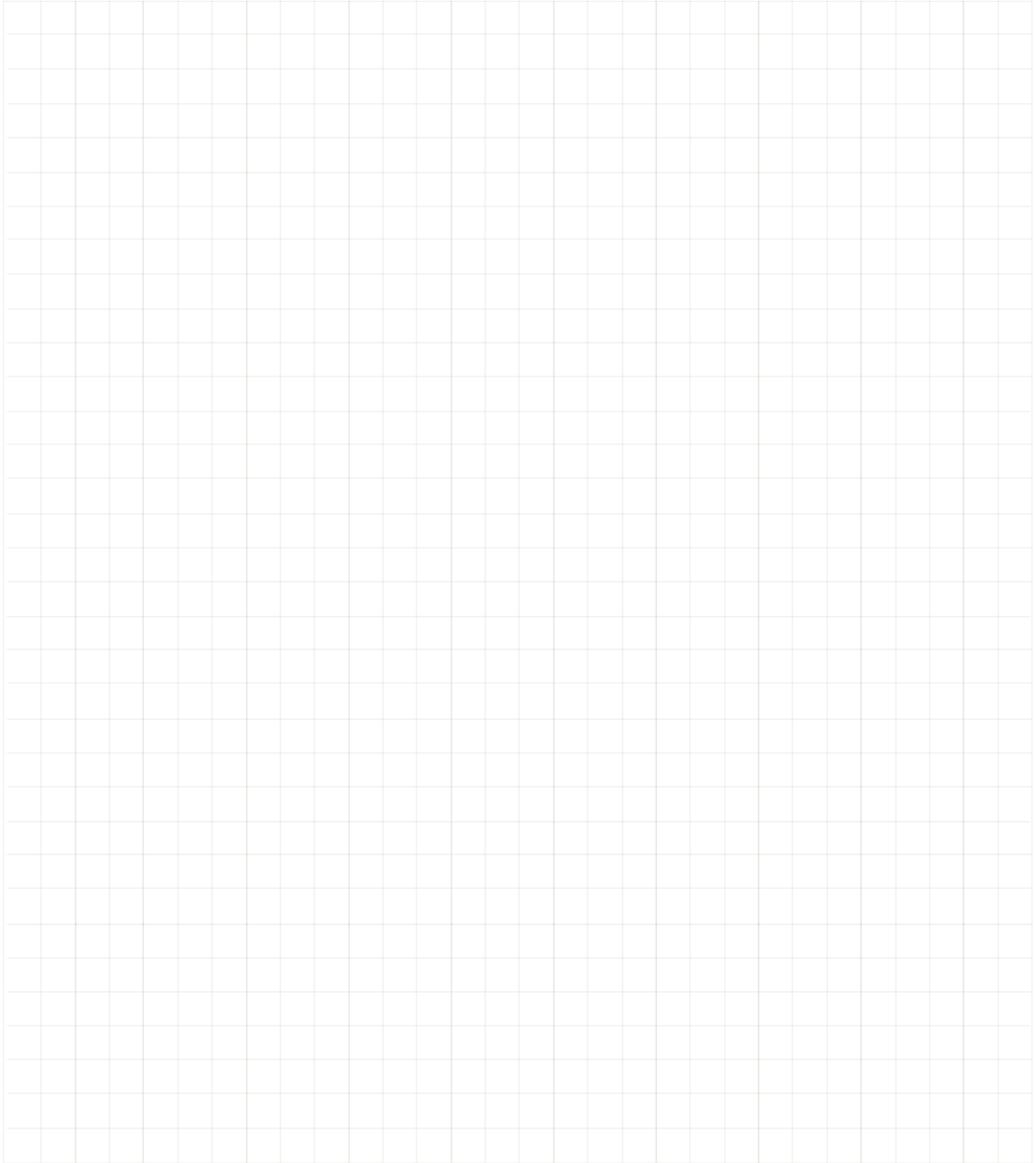
A large grid of graph paper for taking notes, consisting of 20 columns and 30 rows of small squares.

Normal use, age and wear on vehicle components can affect the safe operation and reliability of the vehicle. The recommended inspection and maintenance procedures are crucial for safety, performance, reliability and maximum longevity of your vehicle. A damaged vehicle, or a vehicle that is not functioning properly is dangerous and must not be operated until repairs are made.

NOTICE: Read the following operational warnings before driving the vehicle:

⚠ WARNING

Before you leave the vehicle, turn the key to the OFF position and remove the key from the vehicle to prevent unauthorized use.

Drive the vehicle at appropriate speeds for the terrain and conditions. Be aware of environmental conditions that change the terrain and your ability to control the vehicle.

Do not drive on excessively steep hills. Evaluate the terrain before descending a hill. Drive slowly and deliberately. Use the brake to limit speed and maintain control. Sudden braking or turning can cause loss of vehicle control. Drive straight down the hill; do not drive across the hill.

Operate in approved areas.

Keep feet, legs, hands and arms inside vehicle at all times.

Avoid driving on terrain that is too rough for your vehicle's capabilities and your driving skills.

Before you drive in the reverse direction, make sure the area behind the vehicle is clear. Accelerate slowly and avoid making sharp turns.

Make sure the direction selector is in the correct position before you press the accelerator pedal.

Decrease speed before and during turns.

Bring the vehicle to a complete stop before you move the direction selector.

See GENERAL SPECIFICATIONS for the vehicle load and seat capacity.

NOTICE: Read the following maintenance information and warnings before servicing or repairing the vehicle:

Follow the procedures and comply with the safety information in this manual while performing vehicle service or maintenance. Use the tools shown in the tool list and wear the specified safety equipment when performing vehicle service or maintenance.

⚠ WARNING

Remove all jewelry before you service the vehicle.

Do not allow loose clothing or hair to contact the moving parts.

Do not touch hot objects.

The drive wheels must be lifted and supported on jack stands before you perform any service to the powertrain while the motor is in operation.



When you service the vehicle, always wear eye protection. Be careful when working around batteries, using solvents or compressed air.

Use insulated wrenches to decrease the risk of a short-circuit if a wrench contacts the battery terminals. A short-circuit in a battery can cause an explosion.

To prevent the risk of battery explosion, keep all flammable materials, open flames or sparks away from the batteries.

Hydrogen gas is produced as batteries are charged. Charge batteries only in well-ventilated areas.

Maintain constant awareness that some components are heavy, spring loaded, corrosive, explosive, can cause high amperage or get extremely hot. Battery acid and hydrogen gas can cause bodily injury. Keep your hands, face, feet and body away from any area that can expose them to injury if an unexpected situation occurs.



MANUFACTURER INFORMATION

Textron Specialized Vehicles
1451 Marvin Griffin Road
Augusta, Georgia 30906 - 3852
USA

Dealer: 800-296-4804
Consumer: 877-394-6772

www.trackeroffroad.com

Parts Manuals are available at www.trackeroffroad.com.

Copyrighted Material

This manual may not be reproduced in whole or in part without the express permission of the manufacturer.