



OWNER'S MANUAL

OX EV

Automatic Brake

Samsung SDI Lithium Powered

 **WARNING**

Read and comply with all of the instructions and safety precautions in this manual and on all product labels.

Failure to follow the safety precautions could result in serious injury or death.

California Proposition 65

 **WARNING**

Operating, servicing and maintaining a passenger vehicle or off-road vehicle can expose you to chemicals including phthalates and lead, which are known to the State of California to cause cancer and birth defects or other reproductive harm. To minimize exposure, wear gloves and wash your hands frequently when servicing your vehicle.

For more information go to www.P65Warnings.ca.gov/passenger-vehicle.

 **WARNING**

Never modify the vehicle in any way that will alter the weight distribution of the vehicle, decrease its stability or increase the speed beyond the factory specifications. Such modifications can cause serious personal injury or death. The manufacturer prohibits and disclaims responsibility for any such modifications or any other alteration which would adversely affect the safety of the vehicle.

OWNER'S MANUAL

OX EV

Mid-Year 2023 - Current

MANUFACTURER INFORMATION

Textron Specialized Vehicles, Inc.

1451 Marvin Griffin Road

Augusta, Georgia, USA 30906-3852

Dealer: 800-286-4804

Consumer: 877-294-6727

www.trackeroffroad.com

WELCOME

Thank you for purchasing this vehicle. Before driving your new vehicle, read this owner's manual to familiarize yourself with safe driving practices, operation, features and controls.

This manual contains instructions for minor maintenance only. Information about major repairs can be found in the repair manual. Your dealer has thorough knowledge of your vehicle and wants your total satisfaction with your purchase. We recommend you return to your dealership for all of your service needs during, and after the warranty period.

Repair or replacement parts can be purchased from your dealer or through the manufacturer's parts and accessories department.

These are original instructions as defined by 2006/42/EC.

The manufacturer maintains the right to change the design of the vehicle without responsibility to make the changes on units purchased before changes were made. The information in this manual can change without notice.

All information in this owner's manual is based on the latest product information at the time of publication. Due to constant improvements in the design and quality of production components, some discrepancies may be found between your vehicle and the information presented in this publication. The content in this publication is intended for reference use only. The manufacturer is not liable for omissions or inaccuracies. Any reprinting or reuse of the content in this publication, whether whole or in part, is expressly prohibited.

Printed in USA

INTRODUCTION

MANUFACTURER'S INTENDED USE7
 WARRANTY AND REGISTRATION7
 BATTERY PROLONGED STORAGE7
 Storage Preparation8
 Setting State of Charge (SOC)8
 During Storage8
 Extreme Low Temperature Storage8
 Returning Vehicle to Service8
 BATTERY DISPOSAL9
 VEHICLE IDENTIFICATION NUMBERS9
 SERVICE AND PARTS MANUALS9

SAFETY

SAFETY LABELS 11
 Operation (P/N 699801) 11
 Load Bed Label (P/N 74821G01) 12
 Pinch Point Warning (P/N 651671) 13
 Patent Label (P/N 10005569) 13
 Run/Tow Switch Operation (P/N 612594) 13
 Towing/Maintenance (P/N 609987) 14
 Towing Notice (P/N 609694) 14
 MAXIMUM CARGO LOAD / MAXIMUM WEIGHT CAPACITY 14
 TIRE PRESSURE 15
 OPERATOR SAFETY 15
 Unauthorized Operation 16
 Operating without Instruction 16
 Alcohol or Drugs 16
 Passenger 16
 Before Operating 16
 Load Operation 16
 Driving in Reverse 16
 Driving a Damaged Vehicle 17
 Driving at Maximum Speeds 17
 Driving on Public Roads 17
 Turning 17
 Driving Uphill 17
 Driving Downhill 17
 Stalling on a Hill 17
 Tires 17
 Slippery Terrain 17
 BATTERY CHARGING 17
 VEHICLE LIFTING 18
 VEHICLE MODIFICATION 18
 MAINTENANCE SAFETY 18

FEATURES AND CONTROLS

KEY SWITCH/DIRECTION SELECTOR 19

TABLE OF CONTENTS

HEADLIGHT SWITCH	19
STATE OF CHARGE METER	19
HORN	19
CUP HOLDER	19
USB PORT	19
STEERING WHEEL	19
SEAT BOTTOM	19
GLOVE BOX / STORAGE COMPARTMENTS	19
RUN/TOW SWITCH	20
BRAKE PEDAL	20
PARKING BRAKE	20
ACCELERATOR PEDAL	20
TRUCK BED	20
Manual Bed Release Lever	20
CANOPY TOP AND WINDSHIELD	20
 OPERATION	
SAFETY	21
BEFORE INITIAL USE	21
PRE-RIDE INSPECTION	21
ENVIRONMENTAL AWARENESS	21
BATTERY CHARGER	22
On Board Charger	22
PERFORMANCE FEATURES	22
Speed Control	22
Pedal-Up Braking	22
Anti-Stall Feature	23
High Pedal Disable Feature	23
Diagnostic Mode Feature	23
STARTING AND STOPPING THE VEHICLE	23
Starting on a Hill	23
ACCELERATING	23
BRAKING	24
Coasting	24
DRIVING PROCEDURE	24
DRIVING WITH A PASSENGER	24
SLIPPERY SURFACES	25
DRIVING UPHILL	25
TRAVERSING HILLSIDES	25
DRIVING DOWNHILL	25
STALLING ON A HILL	26
DRIVING IN REVERSE	26
PARKING THE VEHICLE	26
HAULING CARGO	27
Maximum Cargo Load / Maximum Weight Capacity	27
Truck Bed (P/N 74821G01)	28
DUMPING THE TRUCK BED	28
TOWING	29

MAINTENANCE

MAINTENANCE SAFETY 31

SCHEDULED MAINTENANCE 31

 Severe Use Conditions 31

SCHEDULED MAINTENANCE CHART 32

RECOMMENDED LUBRICANTS AND FLUIDS 33

REPLACEMENT OF MAINTENANCE ITEMS 33

LIFTING THE VEHICLE 34

 Lifting Front 34

 Lifting Rear 34

 Lowering Vehicle 34

VEHICLE CLEANING AND CARE 35

 Washing the Vehicle 35

 Polishing the Vehicle 35

TIRES 35

 Tire Pressure 36

 Tire Repair 36

 Tire Replacement 36

WHEELS 36

 Wheel Removal 36

 Wheel Installation 37

LIGHTS 37

 LED Headlight Replacement 37

 Taillight 38

FUSE REPLACEMENT 38

CONTROLLER SYSTEM TEST 38

REAR AXLE 38

 Checking the Lubricant Level 38

BRAKES 39

LITHIUM-ION BATTERY PACK 39

BATTERY CHARGING AND MAINTENANCE 40

BATTERY CHARGING 40

BATTERY PROLONGED STORAGE 40

 Storage Preparation 40

BATTERY FAULT DIAGNOSIS 40

TRANSPORTING THE VEHICLE 41

 Hauling the Vehicle 41

 Towing the Vehicle 41

 Manual Release of Automatic Parking Brake 41

SPECIFICATIONS

VEHICLE SPECIFICATIONS 43

APPENDIX A

BATTERY CHARGER USER'S GUIDE 47

INTRODUCTION

The following symbols appear throughout this manual and on vehicle labels. Your safety is involved when these symbols are used. Become familiar with their meanings before reading the manual.



DANGER

DANGER indicates a hazardous situation that, if not avoided, will result in death or serious injury.



WARNING

WARNING indicates a hazardous situation, if not avoided, could result in death or serious injury.



CAUTION

CAUTION indicates a hazardous situation that, if not avoided, could result in minor or moderate injury.



The **PROHIBITION SAFETY SIGN** indicates an action **NOT** to take in order to avoid hazard.



The **MANDATORY ACTION SIGN** indicates an action that **NEEDS** to be taken to avoid a hazard.



WARNING

Failure to comply with the warnings in this manual can result in severe injury or death.



WARNING

Read this entire manual carefully before operating this vehicle. Do not attempt to operate this vehicle until you have thorough knowledge of the controls and features.



WARNING

Regular inspections and maintenance, along with good operating techniques, will help ensure your safe enjoyment of the capabilities and reliability of this vehicle.

This vehicle was designed and manufactured in the United States of America (USA). The standards and specifications in the following information originate in the USA unless otherwise indicated.

When servicing motors, all adjustments and replacement components must be per original vehicle specifications to maintain the USA Federal and State emission certification applicable at the time of manufacture.

MANUFACTURER'S INTENDED USE

This vehicle is designed and manufactured for off road use only. Use on public streets, roads or highways is illegal in most areas and increases the risk of an accident involving other vehicles and people. This vehicle does not meet FMVSS (Federal Motor Vehicle Safety Standards) for public street, road or highway use.

Check all laws and regulations before choosing an area to operate your vehicle.

WARRANTY AND REGISTRATION

Go to www.trackeroffroad.com for vehicle registration.

Use Original Equipment Manufacturer (OEM) approved parts to keep the warranty effective.

All information, including coverage, limitations, exclusions and how to obtain warranty service is included in the literature package with the purchase of the vehicle. It can also be obtained from your dealer.

BATTERY PROLONGED STORAGE

Batteries discharge over time. The rate of discharge changes according to the ambient temperature, the age and condition of the batteries.

Completely charged batteries will not freeze in winter temperatures unless the temperature is less than -75°F (-60°C).

INTRODUCTION

NOTICE: Improper storage may damage, destroy or cause permanent loss of battery capacity. Do not exceed storage time or temperature limits. Batteries must be charged to the correct level before storage. Storing fully depleted batteries will make them permanently unusable.

Storage Preparation

The optimum storage temperature range is between 65°F and 82°F (18°C and 28°C).

- Charge the battery module based on climate during storage period.
 - In cold climates, fully charge the battery module. Make sure that the charging operation is complete and there are no faults displayed on the charger. The green light on the charger should be on, indicating the charge cycle is complete.
 - In hot climates, store the vehicle with a 30% to 50% charge of battery pack capacity.
- Turn the key to the OFF position and remove it from the key switch.
- Check the run - tow switch under the seat, make sure it is set in the TOW/STORAGE position.
- Turn off all accessories.

The storage time for properly charged Lithium-Ion batteries supplied with this vehicle varies based on the ambient temperature.

Temperature	Length of Storage Time
-22°F to -4°F (-30°C to -20°C)	One month at 100% battery charge, all accessories turned off.
-4°F to 113°F (-20°C to 45°C)	Six months at 100% battery charge, all accessories turned off.
113°F to 140°F (45°C to 60°C)	One month at 30% - 50% charge, all accessories turned off.

Setting State of Charge (SOC)

The SOC meter or the hand held programmer may be used to determine the state of charge of the battery module. If the SOC is below 30%, charge the battery module until the state of charge reaches 50%. The charge cycle may be interrupted by disconnecting the charger from the AC power source first, then from the charging receptacle on the vehicle. If the SOC is above 50%, operate the vehicle until the SOC is below 50%.

During Storage

Check the state of charge every 30 days. If the SOC is below 30%, charge the battery module until the state of charge reaches 50%.

Extreme Low Temperature Storage

If the ambient temperature is below -4°F (-20°C) DO NOT:

- turn the vehicle key to the ON position
- drive the vehicle
- tow the vehicle
- charge the vehicle
- operate accessories
- turn the lights on (if equipped)

Returning Vehicle to Service

At the end of the storage period, charge the battery module to 100% before operating the vehicle.

Before charging the vehicle be sure that the ambient temperature is between 14°F (-10°C) and 113°F (45°C) and the vehicle has had time to adjust to the temperature.

BATTERY DISPOSAL



Lithium-Ion batteries are recyclable:

- Contact the distributor or manufacturer for information on returning or recycling used or damaged battery packs.
- Contact local or state environmental department for disposal information.
- Refer to the Maintenance section for additional information.

Record the vehicle identification numbers in the spaces provided below. These identification numbers is required when ordering parts from the manufacturer.

VEHICLE IDENTIFICATION NUMBERS

Vehicle Model Number: _____

Frame PIN: _____

PART A

MODEL _____	
DATE CODE _____	
SERIAL No. _____	
Bar Code	GVW Lb / kg Lb / kg W Batt Nom Power Hp / kw

PART B

Rated Capacity W/Operator lb/kg /	System voltage V
Lb/kg W/O Batt /	Max Draw bar lb/kg /
Max Batt lb/kg /	

SERIAL No. _____

Bar Code

PIN LABEL

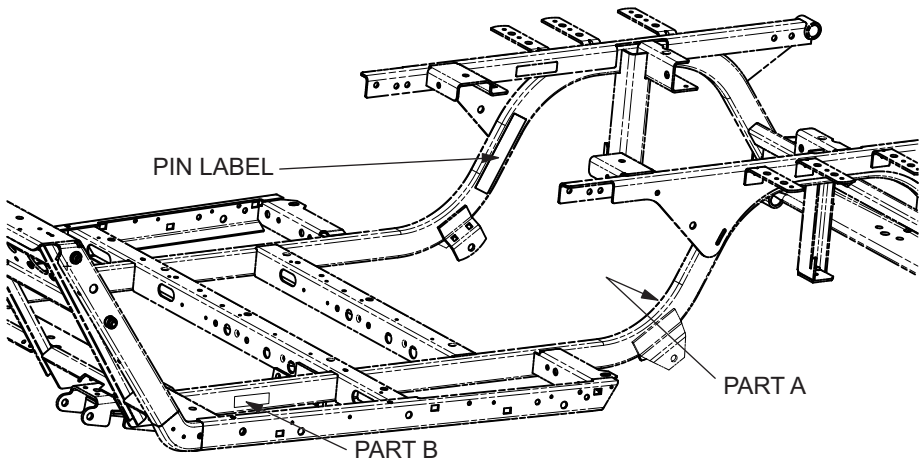

SERVICE AND PARTS MANUALS

The following manuals can be purchased through a dealer:

- service manual
- parts manual

SAFETY

For questions about your vehicle or the material in this manual, see the contact information on page 1 or the back of this publication.

Certain replacement parts can be used independently and/or in combination with other accessories to modify the vehicle to operate at or in excess of 20 mph. When the vehicle is modified in any way by the Distributor, Dealer or customer to operate at or in excess of 20 mph on public streets or roads. UNDER FEDERAL LAW the modified product will be a Low Speed Vehicle (LSV) subject to the strictures and requirements of Federal Motor Vehicle Safety Standard 571.500. In these instances, pursuant to Federal law the Distributor or Dealer MUST equip the product with headlights, rear lights, turn signals, seat belts, top, horn and all other modifications for LSV's mandated in FMVSS 571.500, and affix a Vehicle Identification Number to the product in accordance with the requirements of FMVSS 571.565. Pursuant to FMVSS 571.500, and in accordance with the State laws applicable in the places of sale and use of the product, the Distributor, Dealer or customer modifying the vehicle also will be the Final Vehicle Manufacturer for the LSV, and required to title or register the vehicle as mandated by State law.

Information on FMVSS 571.500 is found at Title 49 of the Code of Federal Regulations, section 571.500. For information online, go to www.ecfr.gov.

The manufacturer will NOT approve Distributor, Dealer or customer changes that change a product into a Low Speed Vehicle (LSV).

This vehicle meets the current applicable standard for safety and performance requirements.

SAFETY LABELS

Safety and warning labels are on the vehicle for your protection. Read and comply with the instructions on the labels carefully. If any label shown in this manual is different from the label on your vehicle, always follow the instructions on the vehicle label.

If a label comes off or becomes illegible, contact your dealer for a replacement. The part number is provided in this manual, printed on the label, or can be obtained from your dealer.

Operation (P/N 699801)

Located on the dash near the steering wheel.

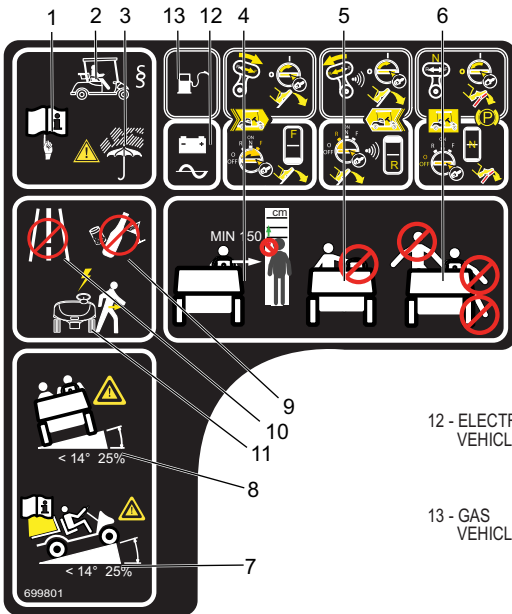

- 1 - READ THE MANUAL
- 2 - DRIVE IN ACCORDANCE WITH LOCAL LAWS AND REGULATIONS
- 3 - USE CAUTION IN BAD WEATHER
- 4 - MINIMUM HEIGHT REQUIRED TO DRIVE
- 5 - NO OPERATION FROM PASSENGER SEAT
- 6 - NO STANDING AND KEEP ENTIRE BODY INSIDE VEHICLE
- 7 - REFER TO OWNER'S MANUAL FOR CARGO INFORMATION
- 8 - MAXIMUM CROSS RAMP OR HILL
- 9 - NO OPERATION IF USING DRUGS OR ALCOHOL
- 10 - NO OPERATION ON PUBLIC ROADS
- 11 - EXIT VEHICLE WHEN LIGHTNING IS IN AREA
- 12 - ELECTRIC VEHICLE

FORWARD OPERATION	REVERSE OPERATION	PARK VEHICLE
- KEY IN F	- KEY IN R	- TURN KEY TO OFF
- PRESS ACCELERATOR GRADUALLY	- PRESS ACCELERATOR GRADUALLY	
- 13 - GAS VEHICLE

FORWARD OPERATION	REVERSE OPERATION	PARK VEHICLE
- TURN KEY TO ON	- TURN KEY TO ON	- PUT DIRECTION SELECTOR IN F
- PUT DIRECTION SELECTOR TO F	- PUT DIRECTION SELECTOR IN R	- TURN KEY TO OFF
- PRESS ACCELERATOR GRADUALLY	- PRESS ACCELERATOR GRADUALLY	- ENGAGE PARKING BRAKE

SAFETY

Load Bed Label (P/N 74821G01)

Located on the truck bed.

WARNING READ THE MANUAL	SECURE LOAD MAX BED WEIGHT	NO PASSENGERS IN LOAD BED	HIGH CENTER OF GRAVITY MAY CAUSE TIP OVER
DO NOT FILL GAS CAN IN LOAD BED	MAX CENTER OF GRAVITY HEIGHT ABOVE FLOOR	MAX TAILGATE LOAD	MAX SIDE SLOPE 14°

MAX 500 lb. 255 kg
MAX 5 in. 12 cm
MAX 100 lb. 45 kg
MAX 14° / 25%

74821G01

Hot Touch Label (P/N 75696G01)



Bed Latch Warning (P/N 74099-G01)

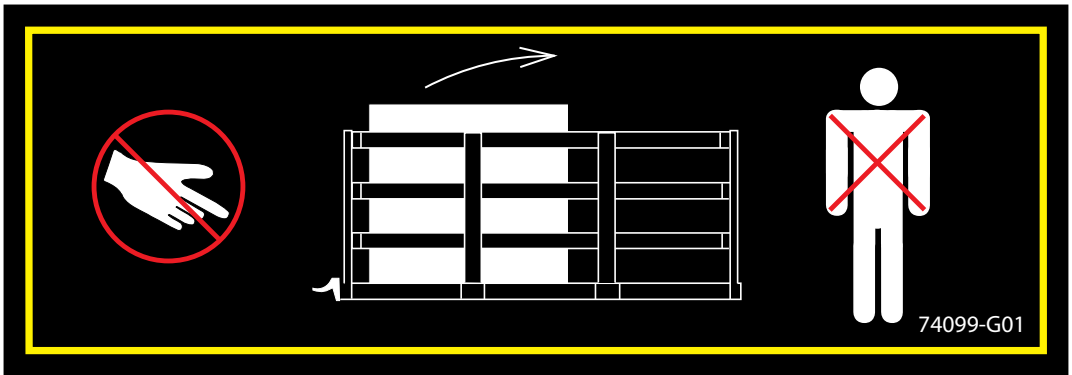

Pinch Point Warning (P/N 651671)



Patent Label (P/N 10005569)

Located in the glove box (driver side).

10005569

PATENT NOTICE

This product or components thereof may be covered by one or more patents or pending applications
See patents.txtsv.com for details.

WARNING CANCER AND REPRODUCTIVE HARM

For more information, go to P65Warning.ca.gov/passenger-vehicle

Run/Tow Switch Operation (P/N 612594)

Located under the seat.

! WARNING

- **DO NOT** alter or tamper with this unit. Unauthorized modifications can result in **SERIOUS INJURY** or damage to the vehicle and will void the warranty.
- To disable electrical system, turn key switch to 'OFF' and remove battery wires.
- **ALWAYS** turn key to 'OFF' before disconnecting or reconnecting battery wires. **ELECTRICAL ARC** or **BATTERY EXPLOSION** can occur if key is not in the 'OFF' position.
- **WAIT 30 seconds** after reconnecting batteries **BEFORE** turning key switch to 'REVERSE', 'FORWARD' or 'NEUTRAL' positions.

TOWING - Always select 'TOW' position before towing

TOW **RUN**

○ ← → |

612594

SAFETY

Towing/Maintenance (P/N 609987)

Located on the controller cover.

⚠ WARNING Failure to follow these instructions can result in **SERIOUS INJURY** or **DEATH**

IF VEHICLE IS INOPERABLE AND NEEDS TO BE MOVED:

- Turn the ignition key to the 'N' position and 'chock' tires to prevent inadvertent movement.
- Flip the RUN-TOW switch to the 'TOW' position and move vehicle to the desired location and park it properly on level ground and chock tires immediately.
- Turn the ignition key to the 'OFF' position, remove key and perform required service procedures following all Safety Guidelines as outlined in your repair manual.

In Case of Total Power Loss and the 'Run-tow' Switch DOES NOT Release the Brake to Move the Vehicle :

- Remove this plastic cover by removing 3 plastic fasteners. See illustrations below.
- See emergency brake release instruction under this panel.



To reuse fastener push center stem up then install fastener through shield into hole.



To secure fastener in place press down on center stem until flush with head of fastener.



609987

Towing Notice (P/N 609694)

Located on the controller cover.

⚠ WARNING Failure to follow these instructions can result in **SERIOUS INJURY** or **DEATH**

THIS PROCEDURE SHOULD ONLY BE TO CLEAR 'VEHICLE FROM AN UNSAFE AREA AND BE PERFORMED ONLY BY QUALIFIED TRAINED PERSONNEL

609694

In Case Of Total Power Loss And The 'Run-tow' Switch Does Not Release The Brake To Move The Vehicle:

- Turn the ignition key to the 'OFF' position and 'chock' tires to prevent inadvertent movement.
- Remove this plastic cover by removing the plastic fasteners.
- Identify the 'Auxiliary Power' line and remove the weather pack seal from the connector.
- Identify the 'Main Harness' connector and disconnect the line.
- Connect 'Auxiliary Power' line to 'Main Harness' which will release the brake. **THIS WILL CAUSE THE VEHICLE TO MOVE IMMEDIATELY IF NOT ON LEVEL GROUND.**
- Move vehicle to the desired location and park it properly on level ground, chock tires, immediately disconnect the 'Auxiliary Power' and reconnect 'Main Harness' for Safety and to avoid battery drain.
- Perform required service procedures following all Safety guidelines as outlined in your repair manual.

MAXIMUM CARGO LOAD / MAXIMUM WEIGHT CAPACITY

⚠ WARNING Exceeding the weight capacities can cause loss of vehicle control and possible injury or death.

Maximum Cargo Load Capacity	500 lbs (227 kg)
Maximum Vehicle Weight Capacity	900 lbs (408 kg)

- Do not exceed the maximum cargo load capacity.
- Do not exceed the maximum vehicle weight capacity (includes weight of operator, passenger, cargo and accessories).

TIRE PRESSURE

⚠ WARNING Improper tire pressure or uneven tire pressure can cause loss of vehicle control and possible injury or death.

Maintaining correct tire inflation pressure is essential for safe vehicle operation. You can vary the inflation pressure, within the recommended range to suit the condition of the terrain.

TIRE PRESSURE RANGE	TERRAIN CONDITIONS	RECOMMENDATION
18 - 22 psi (124 - 152 kPa)	hard surfaces or pavement	Inflate to higher pressure within the range; never exceed maximum pressure indicated.
	soft terrain or turf	Inflate to lower pressure within the range to reduce potential damage to the terrain or turf.

OPERATOR SAFETY

Safe and responsible use of this vehicle is necessary to prevent dangerous conditions for the operator, passengers and other people in the area of operation. This section of the manual provides information on the safe operation of the vehicle. Make sure you read, understand and comply with all of this information to decrease the risk of personal injury or death.

⚠ WARNING Serious injury or death can occur if you do not follow the instructions and procedures shown in this owner's manual.

- Read this entire manual and all product labels carefully. Follow the safety information and operating procedures described.
- Operate your vehicle responsibly to prevent dangerous conditions for the operator, passengers and other people in the area of operation
- Operate your vehicle responsibly and keep the vehicle in safe condition of operation.
- A damaged vehicle, or a vehicle that is not functioning properly is dangerous and must not be operated until repairs are made.
- Do not carry a passenger until you have a minimum of two hours driving experience on this vehicle.
- Keep feet, legs, hands and arms inside the vehicle at all times.
- The driver must keep both hands on the steering wheel and both feet on the floor or a pedal.
- Inspect the vehicle before each use to make sure it is in safe operating condition. Perform the pre-ride inspection described in this manual. See page 21.
- Always have the vehicle checked by an authorized dealer if it is involved in an accident.
- Always put the key switch in the OFF position before you exit the vehicle.
- Remove the ignition key when the vehicle is not in use to prevent accidental starting, unauthorized use by someone below the age of 16, or someone without a driver's license and proper training.
- Drive the vehicle at appropriate speeds for the terrain and conditions. Be aware of environmental conditions that change the terrain and your ability to control the vehicle.
- Do not drive on excessively steep hills. Evaluate the terrain before descending a hill. Drive slowly and deliberately. Use the brake to limit speed and maintain control. Sudden braking or turning can cause loss of vehicle control. Drive straight down the hill; do not drive across the hill.
- Operate only in approved areas. Follow all applicable safety rules for the area.
- Avoid driving on terrain that is too rough for your vehicle's capabilities and your driving skills.
- Before you drive in the reverse direction, make sure the area behind the vehicle is clear. Accelerate slowly and avoid making sharp turns.
- Make sure the direction selector is in the correct position before you press the accelerator pedal.
- Decrease speed before and during turns.
- Decrease speed when driving on wet or slippery surfaces.
- Bring the vehicle to a complete stop before you move the direction selector.
- Do not exceed the cargo or vehicle weight capacities. Do not exceed the occupant capacity. See *SPECIFICATIONS* on page 43 for the vehicle load and seat capacity.
- If there is a risk of lightning, leave the vehicle and look for a safe location to wait until the lightning has stopped.

Additional information about safety is included throughout this manual or can be obtained from your local dealer.

SAFETY

⚠ WARNING Failure to operate this vehicle as instructed can cause collision, loss of control or roll-over resulting in severe injury or death. Follow all safety warnings in this section of the owner's manual. See the **OPERATION** section of the owner's manual for operating procedures and additional safety information.

Unauthorized Operation



This vehicle is for adult use only. Any person below the age of 16 is not permitted to operate the vehicle.

Any person who does not have a valid driver's license is not permitted to operate the vehicle.

Any person who is below the height of 59 in. (150 cm) is not permitted to operate the vehicle.

Leaving the keys in the ignition allows unauthorized operation of the vehicle by someone under 16 years of age, an unlicensed driver or someone who does not meet the height requirement. Always remove the ignition key when the vehicle is not in operation.

Operating without Instruction



Operation of this vehicle without proper instruction increases the risk of an accident. The operator must understand how to operate the vehicle correctly in different situations and on different types of terrain.

All operators must read, understand and comply with the owner's manual and all warning and instruction labels before operating the vehicle.

Alcohol or Drugs



Operation of the vehicle during or after consuming alcohol or drugs can adversely affect operator judgment, reaction time, balance and perception.

Never drink alcohol or use drugs or medications before or during operation of the vehicle.

Passenger

All passengers must be at least 59 in. (150 cm) tall. Passengers must be able to sit with their back against the seat, and both feet on the floor.

For additional safety and operational information, see *Driving with a Passenger* on page 24.

Before Operating

Perform the *PRE-RIDE INSPECTION* on page 21 before each use to make sure the vehicle is in safe operating condition. Failure to inspect and confirm that the vehicle is safe to operate increases the risk of an accident.

Follow all inspection and maintenance procedures and schedules described in this owner's manual. See *SCHEDULED MAINTENANCE* on page 31.

Load Operation

The weight of cargo and occupants affects vehicle operation. Carefully calculate how the vehicle is loaded and how to safely operate it. Follow the instructions in this manual for loading guidelines and tire pressure.

Do not exceed weight capacities specified for your vehicle. Capacities are listed in *Maximum Cargo Load / Maximum Weight Capacity* on page 14 of this manual, and also on the label affixed to the truck bed. As passenger weight increases, cargo weight needs to be adjusted to ensure the maximum vehicle weight capacity is not exceeded.

Tire pressure must be adjusted to accommodate the load being carried. See *Tire Pressure* on page 15 for pressure specifications.

Verify tire pressure, and drive slowly and carefully to maintain control of the vehicle if driving under any of the following conditions:

- passenger and/or cargo exceeds half the maximum weight capacity
- driving over obstacles
- towing
- climbing a hill

Driving in Reverse

Make sure the area behind the vehicle is clear before operating in reverse. After making sure it is clear and safe to operate in reverse, accelerate slowly. Avoid making sharp turns in reverse. Refer to *Driving in Reverse* on page 26 for operational information.

Driving a Damaged Vehicle

Driving a damaged vehicle is not safe.

If your vehicle has been involved in any type of accident, have it inspected by a qualified service dealer to verify that it is safe for operation.

Driving at Maximum Speeds

Maximum speed operation increases risk of loss of control. Always drive at a speed that is appropriate for the terrain, visibility, operating conditions and your skill and experience level. Use the brake to control speed and maintain control of the vehicle.

Driving on Public Roads

Driving this vehicle on public streets, roads or highways could result in a collision with another vehicle. Never drive this vehicle on any public street, road or highway, including dirt and gravel roads, unless they are designated for off road use. Most areas prohibit the operation of this vehicle on public streets, roads or highways, and can result in traffic violations and fines.

Turning

Improper or careless turning can cause loss of traction, loss of control, accident or rollover. Do not turn quickly or at sharp angles. Do not turn at high speeds. Practice turning at slow speeds before attempting to turn at faster speeds.

Driving Uphill

Do not climb hills that are too steep for the vehicle or your driving abilities. Loss of vehicle control or rollover can result from climbing hills incorrectly. Refer to *Driving Uphill* on page 25 for operational information.

Driving Downhill

Inspect the terrain before descending a hill. Avoid driving across hills. Use the brake to limit speed and maintain control. Loss of vehicle control or rollover can result from driving downhill incorrectly. Refer to *Driving Downhill* on page 25 for operational information.

Stalling on a Hill

A rollover can result from stalling or rolling backward while climbing a hill. Drive uphill at a constant speed. See procedure on page 26 for maintaining control of your vehicle if it stalls on a hill.

Tires

Operating the vehicle with incorrect tires or with incorrect or uneven tire pressure can cause loss of control or an accident. Always use the size and type tires specified for the vehicle. See *SPECIFICATIONS* on page 43. Always maintain correct tire pressures as specified in *Tire Pressure* on page 15.

Slippery Terrain

Driving on rough, wet or loose terrain increases the risk of loss of traction or control, accident or rollover. Drive slowly and use correct turning procedures when operating on slippery surfaces.

Tires that have lost traction, and then regain traction suddenly, can cause loss of vehicle control or rollover.

Refer to *Slippery Surfaces* on page 25 for operational information.

BATTERY CHARGING

Charging should be performed when ambient temperatures are between 40°F and 110°F (4°C and 42°C). The battery pack may be charged or topped off after every use.

The battery management system (BMS) and charger cooperate to make sure that charging occurs at the proper rate for the battery temperature. When the battery charger is connected to the vehicle, it will determine the charge rate based on the battery temperature. The charger will operate at the rates shown in the table below.

Charge Rate	Temperature
NO charging	below 14° F (-10°C) or above 140°F (60°C)
Pre-charge (charge at reduced rate, 6 amps)	between 14°F (-10°C) and 41°F (5°C) between 104°F (40°C) and 140°F (60°C)
Full charging	between 41°F (5°C) and 113°F (45° C)

The BMS will adjust the charge rate based on the temperature of the batteries.

Use only the OEM approved Lithium-Ion battery charger for your vehicle. Turn the key to the OFF position and remove it.

- Inspect the charger cord for cracks, frayed wires or loose connections, if damaged, replace it.
- Inspect the vehicle charger receptacle and charger plug for dirt, debris or damage. Clean if necessary and replace immediately if damage is found.
- Connect the charger to a wall receptacle. Do not use a multi-plug adapter or power strip. Do not connect anything else to the same receptacle.
- Connect the charger to the vehicle receptacle.
- When the battery pack is finished charging, disconnect the charger cord from the vehicle. If disconnecting before the charge cycle is complete, it is recommended that the charger be disconnected from the wall receptacle first, then unplug the charger from the vehicle receptacle.

VEHICLE LIFTING

The vehicle must be on a firm and level surface for lifting. Remain constantly aware that the vehicle is not stable during the lifting process. Do not get under a vehicle until you verify that it is stable on the jack stands. Never get under a vehicle while it is on a jack only. Put wheel chocks in front and behind the wheels that are not being lifted. Do not allow anyone to remain or get on the vehicle at any time during the lifting process.

Read and comply with all warnings and follow the lifting procedures described on page 34.

VEHICLE MODIFICATION

Do not install any accessory not approved by the manufacturer. Do not modify the vehicle to increase speed or power. Any modifications or installation of accessories not approved by the manufacturer can create a safety hazard and increase the risk of injury.

The warranty will be terminated if the vehicle is modified to increase vehicle speed or power.

The warranty may be terminated if original (or equivalent) replacement parts are not installed on the vehicle.

The addition of some accessories can change the handling characteristics of the vehicle. Use only manufacturer approved accessories, and familiarize yourself with their function and effect on the vehicle.

MAINTENANCE SAFETY

Routine and scheduled maintenance of this vehicle is necessary to keep your vehicle in safe and reliable condition. This section of the manual provides safety information for performing maintenance on your vehicle. Make sure you read, understand and comply with all of this information to decrease the risk of personal injury or death.



WARNING

Serious injury or death can occur if you do not follow the instructions and procedures shown in this owner's manual.

- Read this entire manual and all product labels carefully. Follow the procedures and comply with the safety information in this manual while performing vehicle service or maintenance.
- Use the tools shown in the tool list and wear the specified safety equipment when performing vehicle service or maintenance.
- Remove all jewelry before you service the vehicle.
- Do not allow loose clothing or hair to contact the moving parts.
- Do not touch hot objects.
- The drive wheels must be lifted and supported on jack stands before you perform any service to the powertrain while the motor is in operation.
- Use wheel chocks and support the vehicle on jack stands. NEVER get under a vehicle that is supported by a jack. Lift the vehicle following instructions. See *LIFTING THE VEHICLE* on page 34.
 - When you service the vehicle, always wear eye protection. Be careful when working around batteries, using solvents or compressed air.
 - Use insulated tools within the battery area to prevent sparks or battery explosion.
 - To prevent the risk of battery explosion, keep all flammable materials, open flames or sparks away from the battery.
- Maintain constant awareness that some components are heavy, spring loaded, corrosive, explosive, can cause high amperage or get extremely hot. Keep your hands, face, feet and body away from any area that can expose them to injury if an unexpected situation occurs.
- After you make repairs or do maintenance, test the vehicle in a safe area that is free from vehicle and pedestrian traffic.



FEATURES AND CONTROLS

NOTICE: Some accessories continue to operate with the key in the OFF position. Leaving these accessories activated after the vehicle is shut down can cause the battery to discharge.

12V accessories must be connected to the DC to DC converter. Converter is rated for 390 Watt output. Exceeding this power rating may result in unintended accessory operation or failure.

KEY SWITCH/DIRECTION SELECTOR

The key switch is a four-position switch.

- OFF; vehicle is disabled.
- REVERSE; activates vehicle electronics and accessory power, and allows driving in reverse direction.
- NEUTRAL; activates vehicle electronics and accessory power.
- FORWARD; activates vehicle electronics and accessory power, and allows driving in forward direction.

HEADLIGHT SWITCH

The LED headlight switch is a three-position switch.

- Upper – Low Beam
- Middle - Daytime Running Lights
- Lower – Off

STATE OF CHARGE METER

The state of charge meter is on the dash panel beside the key switch. It indicates the amount of usable power in the batteries, 100% indicating a full charge on the battery pack and 0% indicating no charge. "LOWBAT" indicates the batteries must be charged immediately. When vehicle is in motion, the meter functions as a speedometer and hour meter.

HORN

The horn switch is the red toggle switch on the console. Press the top of the switch to activate the horn.

CUP HOLDER

The vehicle has a center cup holder that will accommodate two beverage containers. Another cup holder is located to the left of the steering column and will accommodate a larger beverage container.

USB PORT

A USB port is located on the center console.

With the key switch in the ON position, the USB port supplies power to electronic devices via a USB cable.

STEERING WHEEL

The steering wheel allows the driver to control the direction of travel.

SEAT BOTTOM

The bench seat is designed for two occupants.

Lift up on either hip restraint to pivot the seat bottom forward and access the components underneath. Pivot and lift up on the seat to completely remove it from the vehicle.

GLOVE BOX / STORAGE COMPARTMENTS

The glove box provides storage space for small items. Glove boxes may be equipped with optional shelf and/or glove box door.

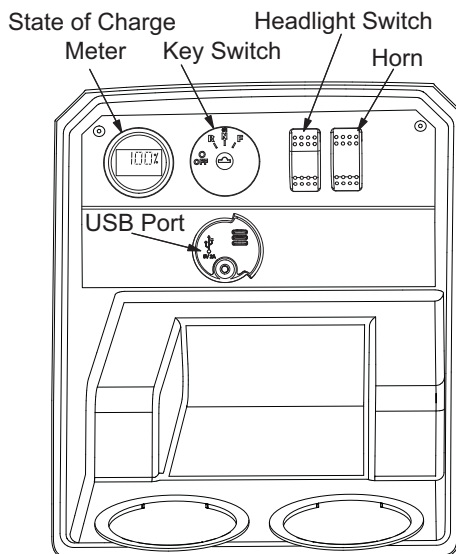

FEATURES AND CONTROLS

RUN/TOW SWITCH

⚠ CAUTION

Before you attempt to tow the vehicle, turn the key switch to N and move the Run/Tow switch to the TOW position. Failure to do so will damage the controller or the motor.

The Run/Tow switch is located under the seat on the driver side of the vehicle.

With the switch in the TOW position and key in N:

- the electronic parking brake is deactivated, which allows the vehicle to be towed or move freely, except in the event a controller failure
- the brake is still active
- the reverse warning beeper is deactivated

With the switch in RUN position:

The electronic parking brake and the reverse warning beeper features are activated. The Run-Tow/Maintenance/Storage switch is for use when the vehicle has become stalled, inoperative or removed from service. The switch is located under the driver's seat.

BRAKE PEDAL

The brake pedal is the bottom left pedal on the floorboard.

Press the brake pedal to slow the speed or bring the vehicle to a complete stop.

PARKING BRAKE

This vehicle is equipped with an automatic parking brake that is activated when the vehicle is stopped. The brake is released when the vehicle is in the F (forward) or R (reverse) position and the accelerator pedal is pressed.

ACCELERATOR PEDAL

The accelerator pedal is the right pedal on the floorboard. It activates the engine and controls the acceleration of the vehicle.

Apply slow and steady pressure to the accelerator pedal to increase vehicle speed.

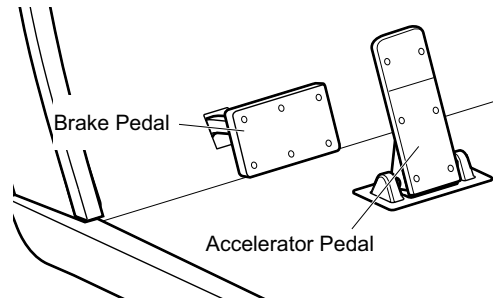

TRUCK BED

To prevent injury and property damage, follow all warnings, procedures, and weight capacities described on the label in the truck bed as well as the ones in this owner's manual. See *HAULING CARGO* on page 27 and *DUMPING THE TRUCK BED* on page 28.

The tailgate can be opened for loading and unloading cargo.

Open the tailgate latches and lower the tailgate.

Lift the tailgate and secure the latches to close the tailgate.

Manual Bed Release Lever

The truck bed can be tilted by lifting up the release lever on either side of the vehicle. See *DUMPING THE TRUCK BED* on page 28.

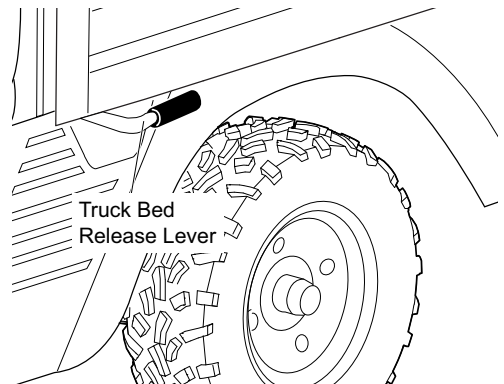

CANOPY TOP AND WINDSHIELD

⚠ WARNING

The canopy top does not provide protection from rollover or falling objects. The windshield does not provide protection from tree branches or moving objects.

⚠ CAUTION

To prevent damage to the vehicle, do not hold on to the canopy top struts.

The canopy top and windshield provide some protection from the elements, but do not keep the operator and passenger dry in heavy rain.

This vehicle is not equipped with seat belts, and the canopy top is not designed to provide rollover protection. In addition, the canopy top does not protect against falling objects, nor does the windshield protect against flying objects and tree limbs.

OPERATION

SAFETY

WARNING Failure to operate the vehicle correctly can result in a collision, loss of control, accident or rollover, and cause serious injury or death. Follow all operation procedures in this section of the manual. Read and comply with all safety warnings in the safety section of this owner's manual.

BEFORE INITIAL USE

To prepare your new vehicle for operation, complete the following:

- Check for possible leaks that may have developed during shipment of the vehicle.
- Charge the batteries.
- Perform the following pre-ride inspection.

PRE-RIDE INSPECTION

Inspect and verify that the vehicle is in safe operating condition before each use to decrease the risk of an accident. Check the items in the table to help ensure safe and reliable operation.

Item	Check	Page
Batteries	Check charge level.	
Brake system/pedal travel	Check for proper operation.	
Parking brake	Ensure vehicle does not roll when the key switch is in the OFF position.	
Front suspension	Inspect. Lubricate if necessary. Check for loose or missing hardware.	
Rear suspension	Inspect. Lubricate if necessary. Check for loose or missing hardware.	
CV boots	Inspect for damage. Replace if necessary.	
Steering	Check for smooth and free operation.	
Tires	Check condition and pressure.	12, 44
Wheel hardware	Check for loose or missing hardware.	
Frame hardware	Check for loose or missing hardware.	
Fluid leakage	Inspect vehicle for leaks.	
Switches	Check operation.	
Reverse warning alarm	Check operation.	
Headlights	Check operation.	37
Brake light / taillights	Check operation.	37

ENVIRONMENTAL AWARENESS

WARNING When driving the vehicle, be careful of potential environmental hazards like steep slopes, rocks, tree branches, etc. that could cause an incident that could result in vehicle damage, personal, injury, or death.

CAUTION There is a risk of fire when the vehicle is operated near combustible material.

Always be respectful of the environment.

Respect all wildlife and their habitat.

Respect private property and comply with all local laws and regulations governing the use of light duty utility vehicles.

Make sure you are permitted by property owners to operate the vehicle on their property.

If operating the vehicle on private property, obtain permission from the owner prior to entering their property.

OPERATION

BATTERY CHARGER

The charger should be operated in accordance with the charger manufacturer's instructions. Never charge batteries in a hazardous environment.

DANGER

Risk of electric shock. Connect the charger power cord to an outlet that is correctly installed and connected to an electrical ground according to all codes and regulations. A grounded outlet is necessary to decrease the risk of electric shock – do not use ground adapters or replace the plug. Do not touch parts of output connector or battery terminals that do not have insulation.

Disconnect the AC plug before you make or break the connections to a battery that is charging. Do not open or disassemble the charger. Do not operate the charger if the AC cord is damaged. Make sure qualified personnel does all repair work to the charger.

Refer to APPENDIX A for the charger manufacturer User's Guide for operating instructions, maintenance instructions and troubleshooting instructions.

WARNING

To prevent over-heating that can cause damage to the charger and possible fire, keep the air fins clear. Install portable chargers on a platform above the ground to allow maximum air flow around and below the charger.

The power AC cord has a plug with a ground post. Do not remove, cut or bend the ground post.

On Board Charger

The on board charger is located under the rear seat. It is wired directly to the batteries. Before charging the batteries, park the vehicle in a well ventilated area and turn key switch to OFF and remove key. Plug charger cord into a dedicated 15 amp AC outlet to activate the charger. When the charging cycle is complete, unplug the charging cord and correctly store the cord.

The battery charger will test the temperature of the battery pack. If the temperature is too hot or too cold the charger will shutdown. If the battery pack temperature is within the safe to charge range, the charger will operate.

PERFORMANCE FEATURES

NOTICE: The speed of the motor is sensed and controlled by the controller.

Speed Control

WARNING

The speed control system is not an alternative for the brake. Use the brake to control speed and decrease the risk of injury.

Speed control system vehicles are equipped with a regenerative motor control system.

Example: If all of the following events occur:

- the vehicle is being driven down a slope
- the vehicle attempts to exceed the specified top speed with the accelerator pedal pressed **or** released

The regenerative brake will limit the speed of the vehicle to the specified top speed but the warning beeper will **not** activate. When the regenerative braking system is activated by this sequence of occurrences, the motor generates power which is returned to the batteries.

If the operator tries to override the electronic brake feature by moving the direction selector or key switch to another position, the warning beeper activates and the vehicle brakes **quickly** until it reaches approximately 2 mph (3 kph).

Pedal-Up Braking

Pedal-up braking is regenerative braking that occurs when the accelerator pedal is released while the vehicle is moving between 8 mph (13 kph) and the vehicle's top speed.

Example: If all of the following events occur:

- the vehicle is being driven down a slope
- the accelerator pedal is released for more than one second

the pedal-up braking decreases speed to 8 mph (13 kph), then the vehicle freely moves without the accelerator pressed, between 8 and 3 mph (5 kph), or the accelerator pedal is applied. The warning beeper will **not** activate. When pedal-up braking is activated by this sequence of occurrences, the motor generates power which is returned to the batteries.

Anti-Stall Feature

Anti-Stall protection prevents motor damage if the vehicle is stalled against an object or on a hill.

Example: If all of the following events occur:

- the system senses that the accelerator pedal is pressed (power applied to motor)
- the motor is stopped long enough that additional time can cause damage to the motor

The Anti-Stall feature will interrupt power to the motor. To restore power to the motor, cycle the key switch from OFF to ON.

High Pedal Disable Feature

High Pedal Disable prevents acceleration of the vehicle if the direction selector is changed or the key is turned on while the accelerator is pressed.

Diagnostic Mode Feature

Diagnostic mode helps with troubleshooting.

With some electrical system failures, the Diagnostic Mode feature defaults to a mode that allows the vehicle to operate at a decreased speed.

This feature allows you to return the vehicle to the storage facility and identify the problem.

The technician can put the controller in diagnostic mode and the controller identifies the failure mode.

STARTING AND STOPPING THE VEHICLE

⚠ WARNING Unintentional roll-back of the vehicle could cause severe personal injury or vehicle damage. To reduce the possibility of vehicle roll-back, keep the brake fully pressed until the motor has started.

All vehicles have an *interlock system* that disables the controller and prevents operation or tow of the vehicle while the charger is connected. Remove the charger plug from the receptacle and correctly store the cable before you move the vehicle.

1. Sit in the driver's seat.
2. Press and hold the brake pedal.
3. Insert the key and turn to the ON position.
4. Move the direction selector to the appropriate position.

NOTICE: *When the direction selector is moved to the reverse position, a warning alarm will activate to indicate that the vehicle is ready to run in reverse.*

5. Slowly press the accelerator pedal to start the motor.
6. When the accelerator pedal is released, the motor decreases the speed of the vehicle. To stop the vehicle more quickly, press the brake pedal.
7. Select the OFF position and remove the key from the switch before exiting the vehicle.

Starting on a Hill

The automatic parking brake will activate when the vehicle stops. To start the vehicle on a hill, press the accelerator pedal and the parking brake will be released.

ACCELERATING

⚠ WARNING Accidental movement of the accelerator pedal can cause the vehicle to suddenly move and cause severe injury or death.

Make sure the key is in the OFF position any time the vehicle is parked.

1. Move the key switch to the ON position.
2. Apply slow, steady pressure to the accelerator pedal to increase vehicle speed. When you release the accelerator pedal, the motor decreases the speed of the vehicle.

OPERATION

BRAKING

⚠ WARNING When carrying cargo or towing a trailer, the weight of the load will increase the braking distance required to slow or stop the vehicle. Not allowing for increased braking distance under load can cause an accident or injury.

1. Release the accelerator pedal completely.
2. Press the brake pedal to slow vehicle speed or stop the vehicle completely.
3. Practice slowing and stopping using the brake to become familiar with the controls.

Coasting

⚠ WARNING Do not allow the vehicle to coast at above recommended speeds. Control vehicle speed with the brake.

The vehicle has a braking feature (pedal-up) that decreases the speed when the accelerator pedal is released. The feature continues to decrease the speed until the vehicle stops. Press the brake if you need to decrease speed or stop the vehicle quickly.

⚠ WARNING Vehicle speed can increase quickly when driving downhill. Allowing the vehicle to coast downhill at high speeds can cause loss of control and result in severe injury or death. Limit your vehicle speed by pressing the brake.

Do not allow the vehicle to coast at speeds that are above the maximum recommended speed. Apply constant brake pressure when descending a hill to control the speed of the vehicle.

DRIVING PROCEDURE

1. Perform the pre-ride inspection. See page 21.
2. Sit in the driver's seat.
3. Check surroundings and determine the path of travel.
4. Press the brake pedal.
5. Insert the key and turn to the ON position.
6. With both hands on the steering wheel, start to apply gradual and steady pressure to the accelerator pedal.
7. Practice maneuvering the vehicle using the accelerator and brake pedals. Drive slowly and cautiously until you are comfortable with the controls.
8. Do not drive with a passenger until you have at least two hours of experience driving this vehicle.

DRIVING WITH A PASSENGER

- All passengers must be at least 59 in. (150 cm) tall. Passengers must be able to sit with their back against the seat, both feet on the floor.
- Do not allow more than one passenger in the vehicle with a truck bed.
- Do not allow a passenger to ride anywhere on the vehicle except the passenger seat.
- Travel at speeds appropriate for your skills, your passenger's skills and the operating conditions. Avoid unexpected or aggressive maneuvers that could cause discomfort or injury to the passenger.
- Handling characteristics can change with the added weight of a passenger. Allow more time and distance for braking.

SLIPPERY SURFACES



WARNING

Skidding or sliding can cause loss of control. Skidding or sliding can cause rollover if tires have lost traction, then regain traction suddenly. When operating on slippery surfaces, travel at reduced speed to help maintain control of the vehicle.

When operating in conditions such as ice, water, muddy trails, loose gravel or freezing temperatures, follow these guidelines:

- Do not operate on excessively rough, slippery or loose terrain.
- Slow down before entering potentially slippery areas.
- Maintain a high level of alertness, carefully evaluate the path of travel and avoid quick, sharp turns.
- Correct a skid by turning the steering wheel in the direction of the skid. *Never apply the brakes during a skid.*

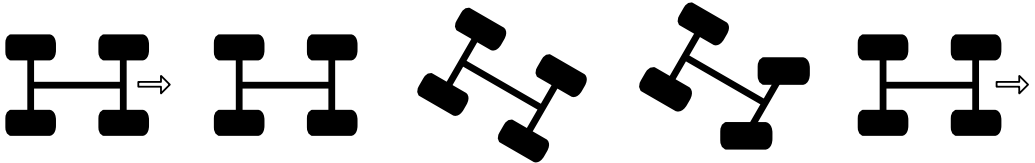

DRIVING UPHILL

When driving up a hill, follow these guidelines:

- Drive straight up the hill.
- Avoid excessively steep hills.
- Keep both feet on the floor or pedals.
- Check the terrain before driving up a hill. Do not try to climb hills that have excessively slippery or loose surfaces.
- Drive at a steady rate of acceleration and speed.
- Do not drive over the crest of a hill at high speed. An obstacle, sharp drop, or another person or vehicle could be on the other side of the hill.
- Do not attempt to drive up a hill that is beyond your skill level.

TRAVERSING HILLSIDES

Traversing a hillside is not recommended. Improper procedure can cause loss of control or a rollover. Avoid crossing the side of a hill unless absolutely necessary. If traversing a hillside is unavoidable, check the terrain and determine if it can be accomplished safely. Do not proceed if the terrain is beyond the vehicle or driver's ability.

If traversing a hillside is unavoidable, follow these guidelines:

- Drive slowly.
- Use extreme caution.
- Avoid crossing the side of a hill that has a slippery surface.
- Avoid crossing the side of a steep hill.
- When traversing a hillside that has soft terrain, it may be necessary to steer slightly uphill to keep the vehicle traveling in a straight line.
- If you feel that you are losing control of the vehicle, steer downhill if possible to regain control.

DRIVING DOWNHILL



WARNING

When carrying cargo or towing a trailer, the weight of the load will increase the braking distance required to slow or stop the vehicle. Not allowing for increased braking distance under load can cause an accident or injury.

When driving down a hill, follow these guidelines:

- Avoid excessively steep hills.
- Check the terrain carefully before descending any hill.
- Never drive down hills with excessively slippery or loose surfaces.
- Drive slowly.
- Drive straight down the hill. Avoid descending the hill at an angle that could cause the vehicle to lean sharply to one side.
- Apply light and constant pressure to the brakes to maintain slow speed and control of the vehicle.

OPERATION

STALLING ON A HILL

A rollover can result from stalling or rolling backward while climbing a hill. Drive uphill at a constant speed.

If your vehicle completely stalls while climbing a hill:

1. Apply the brakes.
2. Verify that the area behind you is clear.
3. Turn the key switch to the R (reverse) position.
4. Use steady brake pressure to control speed, and allow the vehicle to slowly roll straight downhill.

DRIVING IN REVERSE

When driving in reverse, follow these guidelines:

- Check that the area behind the vehicle is clear of obstacles and people.
- Check left and right fields of vision before driving in reverse.
- Do not back down a steep hill.
- Drive in reverse slowly.
- Press the brakes lightly for stopping.
- Accelerate slow and steady.
- Avoid turning at sharp angles.

PARKING THE VEHICLE

NOTICE: *When parking the vehicle in cold climates (0°C, 32° F), the car should be stored in an enclosed garage.*

Park the vehicle on a flat surface if possible. If parking on an incline is unavoidable, be sure to chock the wheels to keep the vehicle from rolling.

1. Press the brake to stop the vehicle.
2. Turn the key switch to the OFF position.
3. Remove the key from the key switch to prevent unauthorized use.
4. If parking on an incline, chock the wheels on the downhill end.

HAULING CARGO

WARNING

Failure to follow these instructions can cause personal injury, damage the vehicle or cause the vehicle to tip over. Be aware of the load when you operate the vehicle. Read, understand and follow the warning label attached to the front of the truck bed.

Hauling cargo incorrectly can alter vehicle handling characteristics and cause loss of control, brake instability, and possibly lead to serious injury or death.

Never exceed the maximum weight capacity of the vehicle. The total load (operator, passenger, accessories, cargo and load on hitch) must never exceed the maximum weight capacity of the vehicle. See the chart in *Maximum Cargo Load / Maximum Weight Capacity* on page 27.

Position the load as far forward, and as low as possible in the truck bed.

Secure all loads before operating. Unsecured loads can shift and create unstable operating conditions.



Operating the vehicle with passengers in the truck bed can result in severe injury or death. Never allow a passenger to ride in the truck bed. Passengers must always ride seated in the passenger seat.

Drive slowly and carefully.

Operate only with stable and safely arranged loads. When handling loads that are impossible to center in the truck bed, make sure the load is secured as tightly as possible and operate the vehicle with extra caution.

ate the vehicle with extra caution.

Always attach a tow load to the rear hitch of the vehicle.

Reduce speed and allow greater distances for braking when hauling cargo.

Heavy loads affect braking and handling characteristics. Use extra caution when applying brakes with a heavily loaded vehicle. Avoid terrain or situations that may require reverse downhill travel.

Use extra caution when operating with loads that extend over the truck bed sides. Stability and maneuverability can be affected and increase risk of rollover.

This vehicle is designed to carry or tow specific capacities. Read and comply with the load distribution warnings on the warning label affixed to the bed. The total load (operator, passenger, accessories, cargo and load on hitch) must never exceed the maximum weight capacity of the vehicle.

Maximum Cargo Load / Maximum Weight Capacity

Maximum Cargo Load Capacity	500 lbs (227 kg)
Maximum Vehicle Weight Capacity	900 lbs (408 kg)

- Do not exceed the maximum cargo load capacity.
- Do not exceed the maximum vehicle weight capacity (includes weight of operator, passenger, cargo and accessories).

OPERATION

Truck Bed (P/N 74821G01)

Located on the truck bed.

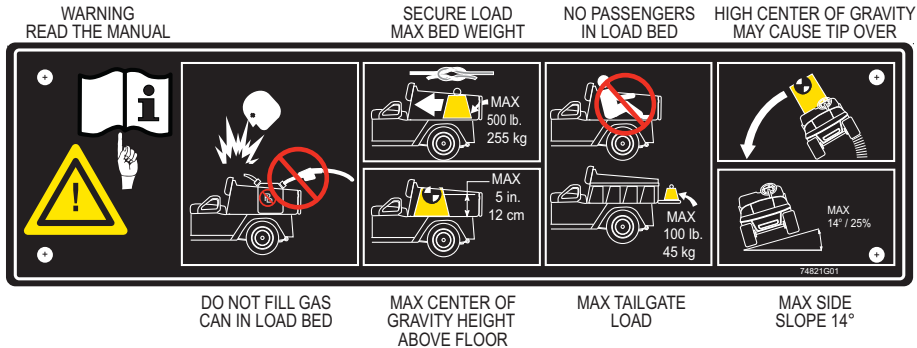

A truck bed warning label is attached to the inside front of the truck bed. Understand and comply with the warnings on this label for safe operation of the vehicle.

- See the truck bed warning label for maximum load.
- Position the load in the truck bed as far forward as possible.
- Make sure the center of gravity of the load is within the height limit shown on label.
- Secure the load to the truck bed.
- Be aware of the load when you operate the vehicle.
- Do not let passengers to ride in the truck bed. Do not drive the vehicle with the truck bed lifted or with the tailgate unsupported.

DUMPING THE TRUCK BED

WARNING If the bulk of the cargo weight is at the rear of the bed, the bed may unexpectedly dump when the release lever is pulled and cause serious injury to anyone close by. Never pull the release lever unless the load is positioned evenly or located at the front of the truck bed.

Never leave the truck bed in the upright position after emptying the cargo. The bed can unexpectedly close and cause serious injury. Never drive the vehicle with the truck bed in the raised position.

1. Select a level location to dump the truck bed load. Do not attempt to dump or unload the vehicle if it is on an incline.
2. Put the key switch in Park (OFF).
3. Exit the vehicle.
4. Make sure the cargo is positioned evenly or located at the front of the truck bed.
5. Release the tailgate latches.
6. Manual bed lift vehicles:
 - a. Stand clear and pull the release handle. Lift up on the truck bed to dump the cargo.
 - b. When the truck bed is empty, lower the bed back into place.
 - c. Push down to latch the bed.
7. Close and latch the tailgate.

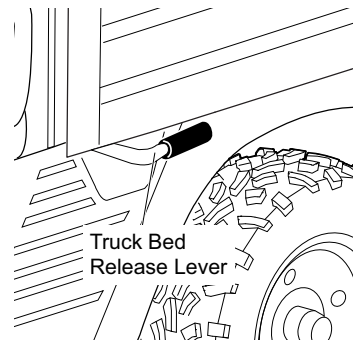

TOWING

NOTICE: Vehicles must be equipped with a rear hitch to tow a load.

 **WARNING**

Attach a trailer to the tow hitch only. Attaching the trailer at any other location can cause loss of vehicle control.

Do not attach baskets or extensions to the hitch receiver. These types of items change the performance qualities of the vehicle and cause dangerous handling characteristics, possible rollover or vehicle damage.

When towing a load, follow these guidelines:

- Do not tow more than the recommended towing weight for the vehicle. See the following table and the *SPECIFICATIONS* on page 43.

VEHICLE LOADING	MAX. WEIGHT
Occupant Capacity	400 lbs (181.4 kg)
Cargo Capacity	500 lbs (227 kg)
Vehicle Rated Capacity = Occupant + Cargo	
VEHICLE WEIGHT	
Curb Weight (with batteries)	1009 lbs (458 kg)
Gross Weight = Curb Weight + Rated Capacity	1909 lbs (867 kg)
VEHICLE TOWING (0% - 20% GRADE)	
Maximum Trailer Tongue Weight	150 lbs. (68 kg)
Maximum Gross Trailer Weight	1200 lbs. (544.3 kg)
Maximum Vehicle Combined Towing Weight = Curb Weight + Rated Capacity + Trailer	2171 lbs. (985 kg)
Maximum Vehicle Drawbar (Level Ground & Improved Surfaces)	1174 lbs. (5222 N)

- The total capacity of the vehicle, operator, passenger, load bed contents and accessories must be reduced to compensate for the trailer and load.
- The range of motion of the trailer is limited by the ball and hitch. Do not tow a trailer on rough terrain.
- Drive slowly and carefully.
- Towing a load increases braking distances required for slowing or stopping the vehicle.
- Do not attach baskets or extensions to the hitch receiver.
- Avoid parking on an incline.
- Do not operate on a grade exceeding 20%.
- Always secure the cargo.

MAINTENANCE

MAINTENANCE SAFETY



To prevent serious injury or death, follow the procedures and comply with the safety information in this manual while performing vehicle service or maintenance.

Use the tools shown in the tool list and wear the specified safety equipment when performing vehicle service or maintenance.

Remove all jewelry before you service the vehicle.

Do not allow loose clothing or hair to contact the moving parts.

Do not touch hot objects.

Make sure that the key switch is in the OFF position and the run/tow switch is in the RUN/STORAGE (See *Run/Tow Switch Operation (P/N 612594)* on page 13) position before you start to work on the vehicle.

Disconnect the negative battery terminal before you service the vehicle to prevent accidental operation.

The drive wheels must be lifted and supported on jack stands before you do any service to the powertrain when the motor is in operation.

Chock the wheels and support the vehicle with jack stands. NEVER get under a vehicle that is supported by a jack. Lift the vehicle according to the manufacturers instructions.

Wear a face shield when working around the battery pack.

Be careful when working around batteries, using solvents or compressed air.

Use insulated tools within the battery area to prevent sparks or battery explosion.

To prevent the risk of battery explosion, keep all flammable materials, open flames or sparks away from the battery.

Maintain constant awareness that some components are heavy, spring loaded, corrosive, explosive, can cause high amperage or get extremely hot.

After you make repairs or do maintenance, test the vehicle in a safe area that is free from vehicle and pedestrian traffic.

NOTICE: To decrease the risk of damage to the controller or motor, move the run/tow switch to the TOW position before you tow the vehicle.

After you connect a battery or any other wires, wait a minimum of 30 seconds before you move the switch to the RUN position.

SCHEDULED MAINTENANCE

Consistent inspection, adjustment and lubrication of some components are necessary to maintain your vehicle so that it remains in safe and reliable condition. Refer to the *SCHEDULED MAINTENANCE CHART* on page 32 for detailed requirements.

Inspect, clean, lubricate, adjust and replace parts as necessary. Use OEM or equivalent replacement parts.

Record the maintenance items performed along with details in the *MAINTENANCE LOG* on page 45.

NOTICE: Service and adjustments are important for safe and reliable vehicle operation. If not familiar with safe service and adjustment procedures, have your dealer perform the operations.

Severe Use Conditions

Vehicles subjected to heavy or severe use must be inspected and serviced more frequently than those of normal use patterns. The following conditions are considered severe use:

- frequent or prolonged use in a dusty environment
- frequent use in mud, water or sand
- prolonged low speed operation
- short trips in cold weather
- prolonged heavy load operation

MAINTENANCE

SCHEDULED MAINTENANCE CHART

Perform all services at the maintenance interval reached first.

S – Indicates operations that need to be performed on vehicles subjected to severe use.

Item	Interval (perform at interval that comes first)		Remarks	Page
	Hours	Calendar		
Overall vehicle condition	Pre-ride		Inspect.	
Battery module	Daily		Charge daily after use.	
Steering	Pre-ride		Check for smooth and free operation.	
Front suspension	Pre-ride		Inspect. Check for leaks and loose or missing hardware.	
Rear suspension	Pre-ride		Inspect. Check for leaks and loose or missing hardware.	
Tires	Pre-ride		Check condition and pressure.	15
Wheel lug nuts	Pre-ride		Check for loose or missing.	36
Accelerator	Pre-ride		Check for smooth operation.	
Brake system	Pre-ride		Check for smooth operation and acceptable stopping distance.	
Frame hardware	Pre-ride		Check for loose or missing.	
Headlights and taillights	Pre-ride		Check operation. Replace bulbs as needed.	37
Reverse warning alarm	Pre-ride		Check operation.	
Switches	Pre-ride		Check operation.	
Fluid leakages	Pre-ride		Inspect entire vehicle for leaks	
S Brake shoes	10	Monthly	Inspect. Replace as needed.	
Charger receptacle	20	Monthly	Clean connections.	
Accelerator	20	Monthly	Check for smooth operation.	
Wiring	20	Monthly	Inspect for loose connections, broken or missing insulation.	
Steering	20	Monthly	Check for excess play, loose or missing hardware.	
S Tie rods	20	Monthly	Check for excess play, bent rods, loose or missing hardware.	
Front suspension	20	Monthly	Inspect strut for leaks. Check hubs and kingpins, for excessive play, worn bushings, loose or missing hardware.	
Rear axle	20	Monthly	Check for leakage; add oil as required.	
Brakes	20	Monthly	Check for smooth operation and acceptable stopping distance.	
Front wheel alignment	60	3 Months	Check for unusual tire wear.	
Rear suspension	60	3 Months	Check for shock oil leakage, worn bushings, loose or missing hardware.	
Rear axle	500	5 years	Replace fluid.	
Motor coupling	20,000 Amp Hours	5 years	Add anti-seize compound (approx. 1 tbsp.)	

RECOMMENDED LUBRICANTS AND FLUIDS

Check and lubricate all components at the intervals shown in the *SCHEDULED MAINTENANCE CHART* beginning on page 32.

Item	Capacity	Lubricants/Fluids	Notes
Rear axle oil	25 oz. (0.7 L)	Mobil 424	Part Number 603967
Rear axle oil	2.0 oz (59 mL)	Friction Modifier E-Z-GO	Part Number 611242
Grease fittings		Universal joint grease or equivalent	Do not exceed 3 pumps of grease in each fitting.

REPLACEMENT OF MAINTENANCE ITEMS

These items or their equivalents can be purchased through your dealer or from any other qualified source.

Item	Part Number
58V, 10A Mini Fuse	636455G22
32V, 15A Mini Fuse	636455G13
32V, 5A Mini Fuse	636455G10
32V, 10A Mini Fuse	636455G12
12V, 20A Relay	643691
LED Headlight Assembly	651411G04
LED Taillight	10023553

MAINTENANCE

LIFTING THE VEHICLE

⚠ WARNING Read and comply with all of the following warnings and lifting procedures to prevent the possibility of the vehicle falling and causing serious injury or death.

For some maintenance procedures, it is necessary to lift the vehicle. Comply with the following warnings and follow the lifting procedure to ensure the safety of you, your vehicle and surroundings.

⚠ WARNING The vehicle must be on a firm and level surface for lifting.

Remain constantly aware that the vehicle is not stable during the lifting process.

Place the jack and jack stands only in the areas indicated in the following illustration.

Do not get under a vehicle until it's stability on the jack stands is verified; never get under a vehicle while it is on a jack only.

Put wheel chocks in front and behind all wheels that are not being lifted.

Do not allow anyone to remain or get on the vehicle at any time during the lifting process or when the vehicle is lifted.

When performing any service to the drive-train, lift drive wheels off the ground.

Tools

- jack
- jack stands (4)
- wheel chocks

Lifting Front

1. Chock the rear wheels to keep the vehicle from rolling backward.
2. Put a jack under the center of the front axle.
3. Raise the vehicle with the jack.
4. Install a jack stand under the front frame cross member as shown.
5. Lower the vehicle until it rests on the jack stands.
6. Remove the jack.
7. Confirm that the vehicle is stable on the jack stands before proceeding with any service.

Lifting Rear

1. Chock the front wheels to keep the vehicle from rolling forward.
2. Put a jack under the center of the rear frame cross member.
3. Raise the vehicle with the jack.
4. Install a jack stand under each end of the rear axle.
5. Lower the vehicle until it rests on the jack stands.
6. Remove the jack.
7. Confirm that the vehicle is stable on the jack stands before proceeding with any service.

Lowering Vehicle

1. Make sure chocks are still in place on any wheels that remain on the ground.
2. Put the jack in the same location that was used to raise the vehicle.
3. Raise the vehicle enough to remove the jack stands. Remove the jack stands from underneath the vehicle.
4. Slowly lower the vehicle to the ground and remove the jack.

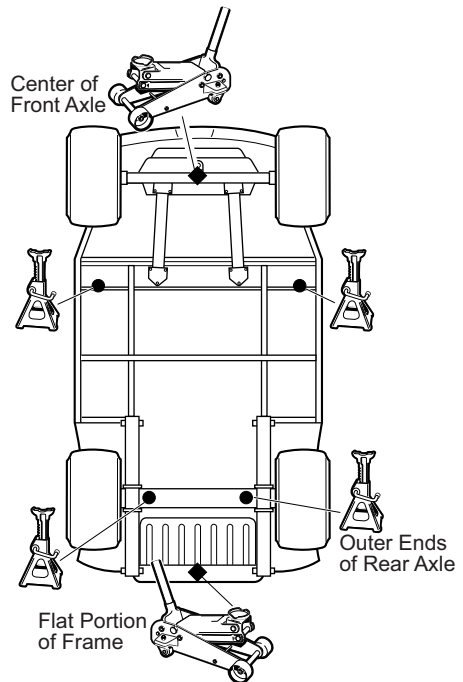

VEHICLE CLEANING AND CARE

Keeping your vehicle clean is not only beneficial to its appearance, but can also help extend the life of various components.

Washing the Vehicle

NOTICE: Do not use a pressure washer to wash your vehicle. High water pressure can damage components.

Some products, including insect repellents and chemicals, will damage plastic surfaces. Do not allow these types of products to contact the vehicle.

- Do not use a pressure washer to clean the vehicle.
- Use an automotive type cleaner or mild soap to wash the vehicle. Harsh cleaners can scratch the finish.
- Use clean or new cloths and pads for washing. Reused cloths and pads can contain dirt particles that will scratch the finish.
- Inspect all grease fittings for dirt intrusion or lack of grease after washing. Apply grease as required to maintain proper function.
- Use a sponge or soft brush and a soap/water solution to clean the vinyl seats. Rinse with clean water.
- Use an automotive type wash cloth to wash the body of the vehicle. To prevent the soap from drying on the vehicle, rinse with clean water frequently.
- Clean the windshield with water and a clean cloth. Remove small scratches with a plastic polish.
- Clean the bottom of the vehicle where mud or dirt can collect. Loosen any packed sediment to help with removal. Be careful not to damage the paint.
- Dry the vehicle with a chamois before the water dries to prevent water spots.

Polishing the Vehicle

- Do not use medium to heavy duty compounds on the finish. Use wax that is for clear coat automotive finishes only. Do not apply wax or polish to matte finish surfaces.
- Use clean or new cloths and pads for polishing. Old or reused cloths and pads can contain dirt particles that will scratch the finish.

TIRES

Follow the tire maintenance procedures as instructed in this manual and on the labels on the vehicle.

Always use approved size and type of replacement tires. (See *SPECIFICATIONS* on page 43)



Worn, improperly inflated, improper sized, or incorrectly installed tires will affect vehicle handling and could cause an accident resulting in severe injury or death.

Inflate all tires to the same pressure. Operating with unequal or incorrect pressure can adversely affect steering and handling and could cause an accident resulting in severe injury or death.

To decrease the risk of tire explosion, do not exceed the tire inflation rating on the tire sidewall. Make sure the tires are properly inflated at all times of operation. (See *Tire Pressure* on page 36)

To decrease the risk of tire explosion, inflate small amounts of air into the tire at intervals to allow the beads to seat properly. Because of the low volume of the small tires, over inflation can occur in seconds. Never exceed the tire inflation pressure rating on the tire sidewall when seating a bead. Protect your face and eyes when you remove a valve core.

When you remove the wheels, use only sockets made for impact wrenches to decrease the risk of injury by a broken socket.

Do not use tires with low rated pressure. Do not use tires that have a recommended tire inflation pressure less than the tire inflation pressure recommended in the owner's guide.

Do not over inflate the tires. Excess pressure can cause the tire to separate from the wheel or cause a tire explosion.

MAINTENANCE

Tire Pressure

Maintaining correct tire inflation pressure is essential for safe vehicle operation. You can vary the inflation pressure, within the recommended range to suit the condition of the terrain.

TIRE PRESSURE RANGE	TERRAIN CONDITIONS	RECOMMENDATION
18 - 22 psi (124 - 152 kPa)	hard surfaces or pavement	Inflate to higher pressure within the range; never exceed maximum pressure indicated.
	soft terrain or turf	Inflate to lower pressure within the range to reduce potential damage to the terrain or turf.

Tire Repair

Tools

- lug wrench, 3/4"
- impact socket, 3/4"
- impact wrench
- torque wrench, ft.lbs.

NOTICE: *Tire plug tools and plugs are available at automotive outlets. The tire does not have to be removed from the wheel to install the tire plug.*

Use a tire plug to repair small holes in the tread part of the tire. For large holes or holes/cuts in the tire sidewall, the tire must be replaced.

1. Remove the wheel from the vehicle. (See *Wheel Removal* on page 36)
2. Locate the leak in the tire.
 - a. If the tire is very low or flat, fully inflate the tire.
 - b. Brush soapy water over the surface of the tire. Air bubbles will be visible where the air is leaking from the tire.
 - c. Mark the hole with chalk.
3. Install the plug according to the manufacturer's instructions.
4. Install the wheel on the vehicle. (See *Wheel Installation* on page 37)
5. Fully inflate the tire. (See *Tire Pressure* on page 36)

Tire Replacement

Tire replacement requires a tire mounting machine and must be done by a qualified tire center or your dealer.

WHEELS

⚠ WARNING Worn, improperly inflated, improper sized, or incorrectly installed tires will affect vehicle handling and could cause an accident resulting in severe injury or death.

⚠ CAUTION To decrease the risk of component damage, do not tighten the lug nuts to more than the torque specified below.

Check lug nuts for tightness at the intervals indicated in the *SCHEDULED MAINTENANCE CHART* on page 32.

Wheel Removal

Tools

- lug wrench, 3/4"
- impact socket, 3/4"
- impact wrench
- torque wrench, ft. lbs.

1. Lift the vehicle. (See *LIFTING THE VEHICLE* on page 34)
2. Remove the lug nuts.
3. Remove the tire from the vehicle.

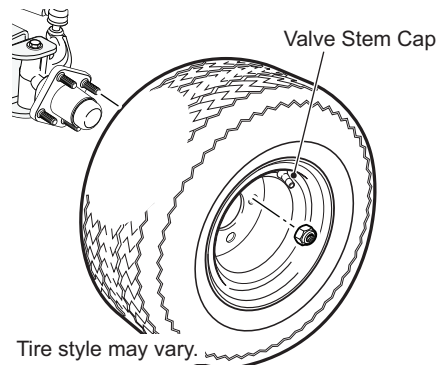

Wheel Installation

Lug Nut Torque	65 - 85 ft.lbs. (88 - 115 Nm)
----------------	-------------------------------

NOTICE: To decrease the risk of component damage, do not tighten the lug nuts to more than the specified torque.

Always install lug nuts using a cross sequence pattern to ensure even seating of the wheel against the hub.

1. Install the wheel on the hub with lug nuts. Make sure the valve stem is to the outside.
2. Finger tighten the lug nuts.
3. Using the tightening pattern shown at right, tighten the lug nuts to 65 - 85 ft.lbs. (88 - 115 Nm). Tighten in increments of 20 ft. lbs. (27 Nm).

Lug Nut Tightening Pattern

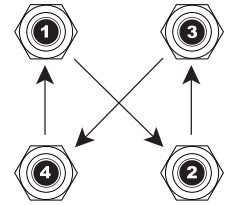

LIGHTS

- Clean the lights frequently to maximize visibility.
- Replace burned out units promptly.

CAUTION Do not operate this vehicle at night or in low light if any lights are burned out. Poor lighting reduces visibility that could cause an accident resulting in severe injury or death.

NOTICE: Replacement lights are available from a local distributor, an authorized branch or the manufacturer.

LED Headlight Replacement

CAUTION Light components can get hot if they have been in operation. Allow the lights to cool before servicing to prevent burns to the skin.

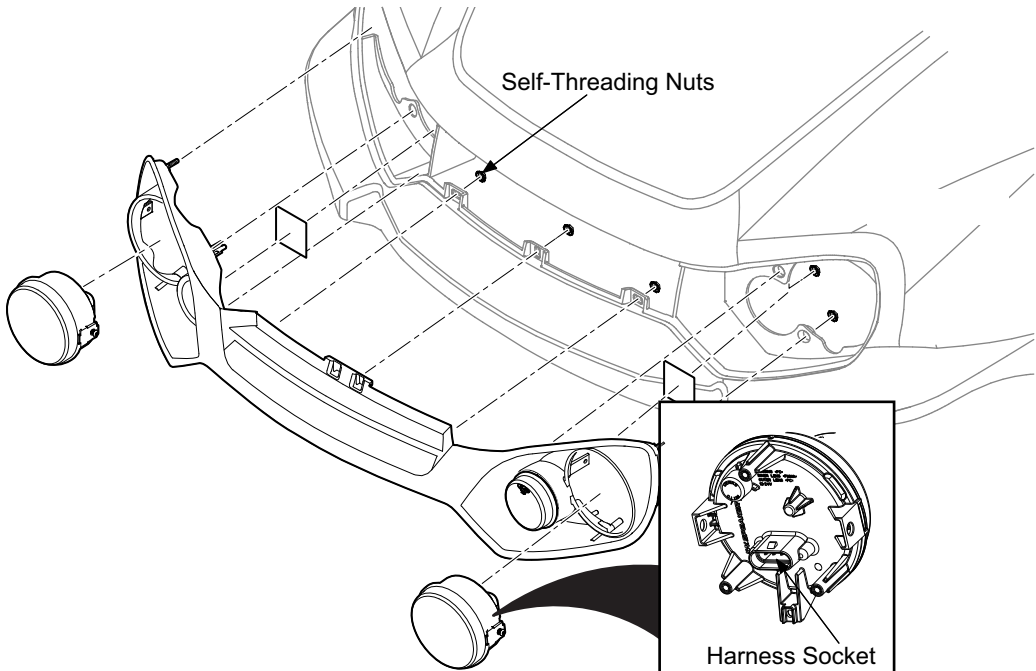

1. Remove the grille assembly by removing self-threading nuts from under the cowl area.
2. Access and remove screws attaching the headlights to the grille.
3. Disconnect the headlight harness from the headlight harness socket.

MAINTENANCE

4. Install new headlight using hardware previously removed.
5. Connect the harness to the headlight.
6. Reattach the grill to the cowl using the original self-threading nuts.

Taillight

1. Disconnect the taillight harness from the tail light.
2. Press the tail light assembly out of the grommet by pushing on the back of the assembly.
3. Press the new taillight assembly into the grommet.
4. Connect the harness to the taillight assembly.

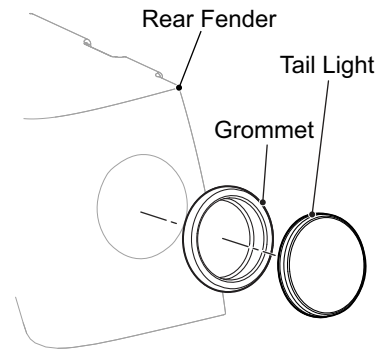

FUSE REPLACEMENT

NOTICE: Have the vehicle inspected by your dealer if fuses continue to blow after they have been replaced.

1. Lift the seat bottom to access the PDM.
2. Open the PDM to access the fuses.
3. Remove the old fuse and replace with a new fuse of the same type and size.
4. Fuses are available from a local Distributor, an authorized Branch or the Service Parts Department.

CONTROLLER SYSTEM TEST

At monthly intervals, test the controller by allowing the vehicle to roll down an incline with the accelerator pedal released. Braking force should be felt at approximately 2 mph (3 kph) indicating that the system is functioning. If vehicle speed continues to rise, apply the brake and have vehicle inspected by a trained mechanic.

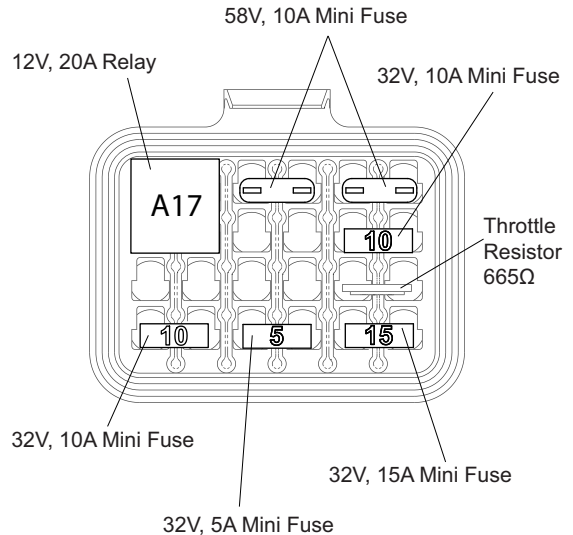

REAR AXLE

The only maintenance necessary for the first five years is the inspection of the rear axle for lubricant leakage. Unless leakage is visible, the lubricant needs to be replaced after five years. Refer to the Service and Repair Manual for the fluid replacement procedure.

Change the axle oil at the intervals indicated in the *SCHEDULED MAINTENANCE CHART* on page 32.

Checking the Lubricant Level

Clean the area around the check/fill plug and remove the plug. The correct lubricant level is just below the bottom of the threaded hole. If lubricant is low, add lubricant as required. Add lubricant slowly until lubricant starts to seep from the hole. Install the check/fill plug. In the event that the lubricant is to be replaced, the oil pan must be removed or the oil siphoned through the check/fill hole.

BRAKES



WARNING Always inspect the pedal travel before you operate a vehicle to confirm some brake function is present.

All driving brake tests must be done in a safe location with regard for the safety of all personnel.

NOTICE: Over time, a subtle loss of performance may take place; therefore, it is important to establish the standard with a new vehicle.

Test and service the brake system at the intervals indicated in the *SCHEDULED MAINTENANCE CHART* on page 32.

LITHIUM-ION BATTERY PACK

Charge the battery pack using only the OEM approved Lithium-Ion battery charger.



WARNING Improper handling of batteries and electrical components can result in serious injury or death.

Do not remove the battery pack cover. Do not attempt to remove batteries or battery cables. Do not use the battery pack without the control module installed. All battery and electrical service must be performed by an authorized service facility.

All tools used in or around the battery pack area should be insulated. Do not intentionally cause a short to the power terminal (P+, P-, B+, B-) with a metallic object.

Do not use the vehicle or charge the battery pack if the battery pack has become abnormally hot, is discolored, deformed, leaking or has an odd odor. If liquid from the battery pack leaks onto skin or clothes, wash well immediately with fresh, running water. If liquid gets into the eyes, do not rub the eyes. Wash the eyes with fresh, running water and seek medical assistance immediately.

Do not cut, tear or remove the seal tape. Do not disassemble or modify the design, including the electrical circuit, of the battery pack or control module.

To prevent the risk of battery explosion, keep all flammable materials, open flames or sparks away from the batteries. Do not leave the battery pack near a fire or heat source. Do not throw Lithium-Ion batteries into a fire. Do not apply heat to any part of the battery pack or battery management module with a soldering iron. Do not place the battery pack in a microwave oven, dryer or high-pressure container.

Make sure that the key switch is in the OFF position and the run/tow switch is in the RUN/STORAGE (See *Run/Tow Switch Operation (P/N 612594)* on page 13) position before you start to work on the vehicle.

Do not attempt to operate the vehicle or charge the battery pack at temperatures above 140°F (60°C).

Do not immerse or throw the battery pack in water. Do not pressure wash the battery pack.

Do not puncture the battery pack or control module. Do not strike the battery pack with a hammer or heavy weight. Do not step or stand on the battery pack. Do not throw or drop the battery pack on hard surfaces.

If the battery pack terminals are contaminated or dirty, clean them with a dry cloth before using the battery pack.

Keep the battery pack and control module away from static electricity.



WARNING Before recycling or shipping battery pack, make sure that the battery pack terminals are insulated.



Lithium-Ion batteries are recyclable:

- Return discarded batteries to distributor or manufacturer for recycling.
- Contact local or state environmental department for the disposal information.
- Refer to the Maintenance section for additional information.

MAINTENANCE

BATTERY CHARGING AND MAINTENANCE

NOTICE: Do not spray the battery module with water. Do not attempt to add water to the battery module.

Do not charge the batteries if the ambient temperature is below -4°F (-20°C) or above 113°F (45°C). Refer to Appendix A for battery charger operating instructions.

Before connecting the battery charger:

- Park the vehicle, turn the key switch to OFF and remove the key.
- Inspect the charging receptacle for dirt or debris. Clean if necessary.
- Inspect the charger cords for cracks or damage. Replace any damaged cords before use.
- Plug the charger into a receptacle on a dedicated circuit. Do not connect any other devices to the receptacle.
- Connect the charger to the vehicle.

BATTERY CHARGING

The battery charger is designed to completely charge the battery set. The automatic charger determines the correct length of charge for the battery set and turns off when the batteries are charged. Always refer to the instructions supplied with the charger. See Appendix A for charger operating instructions.

BATTERY PROLONGED STORAGE

Improper storage may damage, destroy or cause permanent loss of battery capacity. Do not exceed storage time or temperature limits. Batteries must be charged to the correct level before storage. Storing fully depleted batteries will make them permanently unusable.

Storage Preparation

The optimum storage temperature range is between 65°F and 82°F (18°C and 28°C)

- Charge the battery module based on climate during storage period.
 - In cold climates, fully charge the battery module. Make sure that the charging operation is complete and there are no faults displayed on the charger. The green light on the charger should be on indicating the charge cycle is complete.
 - In hot climates, store the vehicle with a 30% to 50% charge of battery pack capacity.
- Turn the key to the OFF position and remove it from the key switch.
- Check the run - tow switch under the seat, make sure it is set in the TOW/STORAGE position.
- Turn off all accessories.

The storage time for properly charged Lithium-Ion batteries supplied with this vehicle varies based on the ambient temperature.

Temperature	Length of Storage Time
-22°F to -4°F (-30°C to -20°C)	One month at 30%-50% battery charge, all accessories turned off.
-4°F to 113°F (-20°C to 45°C)	Six months at 100% battery charge, all accessories turned off.
113°F to 140°F (45°C to 60°C)	One month at 100% charge, all accessories turned off.

BATTERY FAULT DIAGNOSIS

Refer to the charger instructions in *APPENDIX A* on page 47.

TRANSPORTING THE VEHICLE



WARNING Do not ride or allow other people on a vehicle being transported on a trailer or being towed with another vehicle.

Hauling the Vehicle



WARNING Loose cargo or vehicle components can fly off when the vehicle is being transported. Secure or remove all cargo. Inspect the vehicle for loose components prior to transport.

Do not allow anyone to ride in a vehicle being transported on a trailer.

Remove the windshield before transporting a vehicle on a trailer.

- If the vehicle is being hauled on a trailer or truck at highway speeds, the canopy top must be removed.
 - The rated capacity of the hauling trailer or truck must be more than the weight of the vehicle and load plus 1000 lb (454 kg). (See *VEHICLE SPECIFICATIONS* on page 43) for the weight of the vehicle.
1. Drive the vehicle onto the trailer or truck.
 2. Turn the key switch to the OFF position.
 3. To prevent the loss of the key, remove it from the key switch.
 4. Make sure the seats are secured.
 5. Secure the vehicle to the trailer or truck with tie downs, straps or ropes.

Towing the Vehicle



WARNING Only tow the vehicle for recovery purposes. Before towing, turn the key switch to N and move the Run/Tow switch to the TOW position. Ensure brakes and steering are operable. Always have a person driving the vehicle to steer and operate brakes when it is being towed. Do not tow the vehicle above 5 mph (8kph). Failure to abide by these instructions could cause harm to vehicle and persons involved.

NOTICE: *This vehicle is equipped with an automatic parking brake. When the vehicle is stopped, the parking brake is automatically set. The automatic parking brake is released when the vehicle is in F (forward) or R (reverse) and the accelerator is pressed. The automatic parking brake is also released when the run/tow switch is in the TOW position with the key switch turned to N (neutral).*

Manual Release of Automatic Parking Brake

In case of total power loss and the RUN/TOW switch does not release the automatic parking brake, use the instructions under the controller splash shield. Chock the tires to prevent the vehicle from moving when the brake is released.

To read the instructions, remove three re-usable plastic rivets that secure the controller splash shield to the body and the controller. To remove these rivets, press the center of the rivet with the vehicle key. When the center pin goes into position, the rivet can be removed. Repeat the procedure for each remaining rivet. Turn the splash shield over to read the instructions.



Make sure that the key switch is in the OFF position and chock the tires to prevent the vehicle from moving; Then do the following:

1. Locate the 'Auxiliary Power' line (7) and remove the weather pack seal (8) from the connector.
2. Locate the 'Primary Power' line connector (5) and disconnect it from line (6).
3. Connect the 'Auxiliary Power' line (7) to the 'Primary Power' line (5).
4. Turn the key switch to the neutral 'N' position, which releases the brake. If the tires are not chocked and the vehicle is not on flat ground, the vehicle will move immediately.

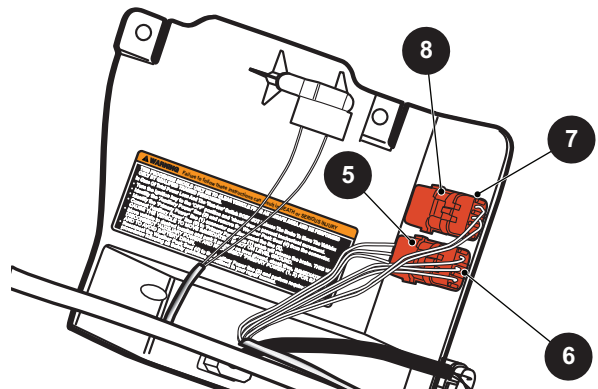

5. Move the vehicle to desired, safe location. Turn the key switch to the 'OFF' position and chock the tires immediately.
6. Disconnect the 'Auxiliary Power' line (7) from the 'Primary Power' line (5).
7. Connect the 'Primary Power' line (5) to line (6).
8. Replace the weather pack seal (8) on the 'Auxiliary Power' line connector (7).
9. To reinstall the controller splash shield, position the splash shield by aligning the mounting holes with the holes in the body, push the center pin of each rivet upward so that the top of the pin is above the rivet head.
10. Place a rivet in each mounting hole of the controller splash shield and push down on the center pin until the top of the pin is flush with the rivet head.



SPECIFICATIONS

VEHICLE SPECIFICATIONS

Item	Specification
Overall Length	121.5 in. (309 cm)
Overall Width	55.2 in. (140 cm)
Overall Height (No Canopy)	58.7 in (149 cm) (Top of steering wheel)
Overall Height (With Canopy)	82.8 in (210 cm)
Wheel Base	77.3 in. (196 cm)
Front Wheel Track	38.2 in. (97 cm)
Rear Wheel Track	38.8 in. (99 cm)
Ground Clearance (at Differential)	11.8 in. (30 cm)
Load Deck Width	44 in. (112 cm)
Load Deck Length	39 in. (99 cm)
Power Source	39.2 - 56.7 Volt Li-Ion Battery
Motor Type	AC Induction
Rated Power Output	14.9 hp (11.1 kW)
Electrical System	48 Volt Primary, 12 Volt Auxiliary
Batteries (Quantity, Type)	Single, 56.7 Max Vol Li-Ion Composite Module and Cell Module ("twin pack")
Key or Pedal Start	Pedal Start
Speed Controller	350 Amp AC
Drive Train	Motor Shaft Direct Drive
Transaxle	Limited-slip differential with helical gears
Gear Selection	Key Switch Forward-Neutral-Reverse
Rear Axle Ratio	16.99:1 (Forward)
Seating Capacity	2 Person
Dry Weight	928 lbs (421 kg) (Without Batteries)
Curb Weight	1009 lbs (458 kg)
Dash/IP Storage Capacity	1123 cu. in. (18403 cm ³)
Load Deck Capacity	500 lbs (227 kg)
Vehicle Load Capacity	900 lbs (408 kg)
Outside Clearance Circle	23.9 ft. (7.3 m)
Speed (Level Ground)	16.5 mph \pm 0.5 mph (26.6 kph \pm 0.8 kph)
Towing Capacity	1200 lbs (544 kg) max load
Steering	Self-compensating rack and pinion
Front Suspension	Leaf springs with hydraulic shock absorbers
Rear Suspension	Leaf springs with hydraulic shock absorbers
Brakes	Dual rear-wheel, mechanical self-adjusting drum
Parking Brake	Automatic Electromagnetic
Front and Rear Tires	KTR Desert Eagle 23x10-14" 4-ply tires
Frame	Welded steel, DuraShield™ powder coat
Front Body and Finish	Injection Molded TPO

APPENDIX A

BATTERY CHARGER USER'S GUIDE



RC900 Onboard Charger Original User Manual

This manual contains important safety and operating instructions for this version of the Delta-Q RC900 Onboard Charger (Part No. 944-0003) for use with E-Z-GO lithium brand vehicles (Model 673928). For manufacturer contact information and technical support, please visit <http://support.delta-q.com/>.

SAVE THESE SAFETY INSTRUCTIONS
This manual contains important safety & operating instructions. Read before using the charger.



Warning

Charge only 48V lithium-ion type batteries activated by Samsung SDI. Other types of batteries may burst causing personal injury and damage. The Samsung Battery Management System (BMS) ensures that in all operating modes, the battery cells are protected from inappropriate levels of voltage, current, temperature, and state of charge. Never charge a frozen battery. Study the battery manufacturer's specific precautions before using this charger.



Danger

Risk of electric shock. Connect charger power cord to an AC outlet that has been properly installed and grounded in accordance with all local codes and ordinances. A grounded AC outlet is required to reduce the risk of electric shock—do not use ground adapters or modify the plug. Do not touch uninsulated portions of the output connector or uninsulated battery terminals. Disconnect the AC supply before making or breaking the connections to the battery. Do not open or disassemble the charger. Do not operate this charger if the AC supply cord or DC output cord is damaged or if the charger is damaged in any way. Refer all repair work to the manufacturer, or qualified personnel. This charger is not intended for use by persons (including children) with reduced physical, sensory or mental capabilities, or lack of experience and knowledge on electrical systems and battery charging, unless they have been given supervision or instruction concerning use of the charger by a person responsible for their safety. Children should be supervised to ensure they do not play with the charger.

Manuel d'origine de l'utilisateur du Chargeur À bord RC900

Le présent manuel contient d'importantes consignes de sécurité et d'utilisation pour cette version du chargeur Delta-Q à bord RC900 (numéro de référence 944-0003) pour utilisation avec les véhicules de marque E-Z-GO alimentés par des batteries au lithium-ion (Modèle 673928). Pour les coordonnées et le soutien technique du fabricant, visitez <http://support.delta-q.com/>.

CONSERVEZ CES CONSIGNES DE SÉCURITÉ
Le présent manuel contient d'importantes consignes de sécurité et d'utilisation. Lisez-les avant d'utiliser le chargeur.



Attention

Chargez uniquement les batteries au lithium-ion 48 V activées par Samsung SDI. Les autres types de batteries pourraient exploser causant des blessures corporelles et des dommages. Le système de gestion des batteries intégrés (BMS) garantit que dans tous les modes de fonctionnement, les cellules de la batterie sont protégées contre les niveaux inappropriés de tension, de courant, de température et d'état de charge. Ne chargez jamais une batterie gelée. Prenez connaissance des mesures de précaution spécifiées par le fabricant de la batterie avant d'utiliser ce chargeur.



Danger

Risque de décharge électrique. Toujours connecter le cordon d'alimentation du chargeur à une prise de secteur CA proprement installée et mise à la terre conformément à tous les codes et règlements locaux.. Une prise secteur CA mise à la terre est nécessaire pour réduire le risque de choc électrique - n'utilisez pas d'adaptateurs de terre et ne modifiez pas la fiche. Ne pas toucher les parties non isolées du connecteur de sortie ou les bornes non isolées de la batterie. Déconnectez la source CA avant de faire ou défaire les connexions à la batterie en chargement. Ne pas ouvrir ni désassembler le chargeur. Ne pas utiliser le chargeur si le cordon d'alimentation CA ou le cordon de sortie CC est endommagé ou si le chargeur est abîmé suite à une chute ou autre incident – Référez toute réparation au fabricant ou aux personnes qualifiées. Cet appareil n'est pas destiné à un usage par des personnes (dont les enfants) avec des facultés motrices, sensorielles ou mentales réduites, ou ayant une expérience et des connaissances insuffisantes, à moins qu'elles sont sous la supervision ou reçoivent les instructions sur l'utilisation de l'appareil par une personne responsable de leur sécurité. Les enfants doivent être surveillés afin qu'il ne jouent en aucun temps avec le le chargeur.

Operating & Maintenance Instructions

- ❖ The charger may become hot during charging. Do not touch the charger when it is charging.
- ❖ To maintain safe operations, the unit automatically reduces its output power if the temperature rises above set thresholds, or if the AC input voltage is too low. The charger also reduces output power if it detects the battery pack is damaged.
- ❖ If power is interrupted, and then returns, the charger starts and continues to operate without hazard to the user, or damage to the batteries.
- ❖ Unplug the charger from AC when cleaning, moving, or conducting any maintenance or repair on the vehicle. No user serviceable parts are inside the charger. Do not remove the charger or the cover due to the risk of electrical shock.
- ❖ Do not expose the charger to oil, dirt, mud, or direct heavy water spray when cleaning the vehicle or machine.
- ❖ The enclosure on these chargers meets IP56, making it protected from dust ingress and powerful water jets. The AC receptacle requires an external AC cord which is not protected against dust or water. Protect this AC connection if the charger is used in wet or dusty environments. Inspect it regularly for contamination. If the charger and/or cord are in a damp location, use a Class A GFCI AC outlet.
- ❖ If the detachable AC input power cord or DC output cord is damaged, do not use the charger until they are replaced by a qualified service technical with cord sets appropriate to your region and application.
- ❖ To charge your vehicle, use a 3-wire extension cord less than 30m (100') at 10 AWG or 7.5m (25') at 16 AWG, per UL guidelines.

AC Receptacle Indicators

LED	Indication
Off	No AC Power. Check for AC cord damage; plug into AC power outlet; ensure AC outlet has power.
Slow Green Breathing	More than 80% state of charge.
Fast Green Breathing	Less than 80% state of charge.
Solid Green	Charge Complete
Rapid Amber Flash	Error. Unplug and plug the charger in again. If the error remains, contact a qualified service technician.
Solid Red	Fault. Unplug and plug the charger in again. If the fault remains, contact a qualified service technician.



Identifying Charger Serial Number

The serial number is printed on the front of the charger. Use this number when requesting technical support.



NOTE: This equipment has been tested and found to comply with the limits for a Class B digital device, pursuant to Part 15 of the FCC/ICES Rules. These limits are designed to provide reasonable protection against harmful interference in a residential installation. This equipment generates, uses, and can radiate radio frequency energy and, if not installed and used in accordance with the instructions, may cause harmful interference to radio communications.

Delta-Q Technologies Corp.
 3755 Willingdon Ave.
 Burnaby, B.C. V5G 3H3 CANADA
 Phone: +1.604.327.8244

Email: support@delta-q.com
 Web: www.delta-q.com
 User Documentation: www.delta-q.com/resources

INDEX

B

battery charger 22
battery disposal 9
battery maintenance 39
brakes 39

C

capacity
 cargo load 14, 27
 fluids 33, 43
 hitch 29, 43
 load 43
 towing 29, 43
cargo
 dumping 28
 hauling 27
 maximum load 14, 27
cleaning the vehicle 35

D

driving procedures
 accelerating 23
 braking 24
 downhill 25
 parking 26
 passenger 24
 reverse 26
 slippery surfaces 25
 stalling on hill 26
 traversing hillsides 25
 uphill 25

F

fluids
 capacities 33
 recommended 33

G

glove box 19

H

hauling, vehicle 41
headlights 37
hitch weight capacity 29
horn switch 19

K

key switch 19

L

labels, safety 11
lifting, vehicle 18, 34

lubricants, recommended 33

M

maintenance
 chart 32
 fluid capacities 33
 recommended fluids and lubricants 33
 scheduled 31

O

operator safety 15

P

parking brake 20
pre-ride inspection 21

R

registration information, vehicle 7

S

safety
 cargo 14, 27
 charging battery 17
 driving downhill 17
 driving in reverse 16
 driving uphill 17
 driving with passenger 16
 labels 11
 lifting, vehicle 18, 34
 operation 21
 operator 15
 pre-ride inspection 21
 slippery terrain 17
 stalling 17
 tire pressure 15, 36
 tires 17
 towing 29
 unauthorized use 16
 vehicle modification 18
 weight capacity 14, 27
safety symbols 7
scheduled maintenance chart 32
seat bottom 19
slippery surfaces 25
specifications, vehicle 43
steering wheel 19
storage compartments 19
switches
 horn 19
 key 19

INDEX

T

- tires 35
 - pressure 15, 36
 - repair 36
 - replacement 36
- towing
 - capacity 29
 - speeds 29
- towing, vehicle 41
- transporting the vehicle 41
- truck bed 20
 - dumping 28

U

- USB port 19

V

- vehicle
 - hauling 41
 - specifications 43
 - towing 41
 - transporting 41

W

- warranty information, vehicle 7
- washing the vehicle 35
- weight capacity, maximum 14, 27
- wheels 36, 37
 - axle and wheel nut torques 36
 - wheel installation 37
 - wheel removal 36

Normal use, age and wear on vehicle components can affect the safe operation and reliability of the vehicle. The recommended inspection and maintenance procedures are crucial for safety, performance, reliability and maximum longevity of your vehicle.

A damaged vehicle, or a vehicle that is not functioning properly is dangerous and must not be operated until repairs are made.

NOTICE: Read the following operational warnings before driving the vehicle:

⚠ WARNING

Before you leave the vehicle, turn the key to the OFF position and remove the key from the vehicle to prevent unauthorized use.

Drive the vehicle at appropriate speeds for the terrain and conditions. Be aware of environmental conditions that change the terrain and your ability to control the vehicle.

Do not drive on excessively steep hills. Evaluate the terrain before descending a hill. Drive slowly and deliberately. Use the brake to limit speed and maintain control. Sudden braking or turning can cause loss of vehicle control. Drive straight down the hill; do not drive across the hill.

Operate in approved areas.

Keep feet, legs, hands and arms inside vehicle at all times.

Avoid driving on terrain that is too rough for your vehicle's capabilities and your driving skills.

Before you drive in the reverse direction, make sure the area behind the vehicle is clear. Accelerate slowly and avoid making sharp turns.

Make sure the direction selector is in the correct position before you press the accelerator pedal.

Decrease speed before and during turns.

Bring the vehicle to a complete stop before you move the direction selector.

See GENERAL SPECIFICATIONS for the vehicle load and seat capacity.

NOTICE: Read the following maintenance information and warnings before servicing or repairing the vehicle:

Follow procedures and comply with safety information in this manual while performing vehicle service or maintenance. Use the tools shown in the tool list and wear the specified safety equipment when performing vehicle service or maintenance.

⚠ WARNING

Remove all jewelry before you service the vehicle.

Do not allow loose clothing or hair to contact the moving parts.

Do not touch hot objects.

The drive wheels must be lifted and supported on jack stands before you perform any service to the powertrain while the motor is in operation.



When you service the vehicle, always wear eye protection. Be careful when working around batteries, using solvents or compressed air.

Use insulated wrenches to decrease the risk of a short-circuit if a wrench contacts the battery terminals. A short-circuit in a battery can cause an explosion.

To prevent the risk of battery explosion, keep all flammable materials, open flames or sparks away from the batteries.

Hydrogen gas is produced as batteries are charged. Charge batteries only in well-ventilated areas.

Maintain constant awareness that some components are heavy, spring loaded, corrosive, explosive, can cause high amperage or get extremely hot. Battery acid and hydrogen gas can cause bodily injury. Keep your hands, face, feet and body away from any area that can expose them to injury if an unexpected situation occurs.

MANUFACTURER INFORMATION

Textron Specialized Vehicles
1451 Marvin Griffin Road
Augusta, Georgia 30906 - 3852
USA

877-394-6272

www.trackeroffroad.com

California Proposition 65



WARNING

Operating, servicing and maintaining a passenger vehicle or off-road vehicle can expose you to chemicals including phthalates and lead, which are known to the State of California to cause cancer and birth defects or other reproductive harm. To minimize exposure, wear gloves and wash your hands frequently when servicing your vehicle.

For more information go to www.P65Warnings.ca.gov/passenger-vehicle

Service manuals are available at www.trackeroffroad.com.

Copyrighted Material

This manual may not be reproduced in whole or in part without the express permission of the manufacturer.